

PARTS LIST



2021.08.25

TABLE OF CONTENTS

Chassis System	1
Bonnet System	4
Main Broom Assembly	6
Right-Left Hub Assemblies	8
Side Broom Assembly - before SN 062211241	10
Side Broom Assembly - from SN 062211241	13
Steering System - before SN 062211241	15
Steering System - from SN 062211241	18
Drive system - before SN 062211241	21
Drive system - from SN 062211241	23
Pedal Assemblies - before serial no. 051807363	26
Pedal Assemblies - after serial no. 051807363	28
Control Panel System	30
Transmission System	32
Reduction Motor Assembly	34
Dust Control System	36
Hopper System	38
Electrical Components	40
Decals	42
Accessories 1	44
Accessories 2	46
Accessories 3	48
Accessories 4	50
Accessories 5	52
Recommended spare parts 1	54
Recommended spare parts 2	56
Electric Diagram	58

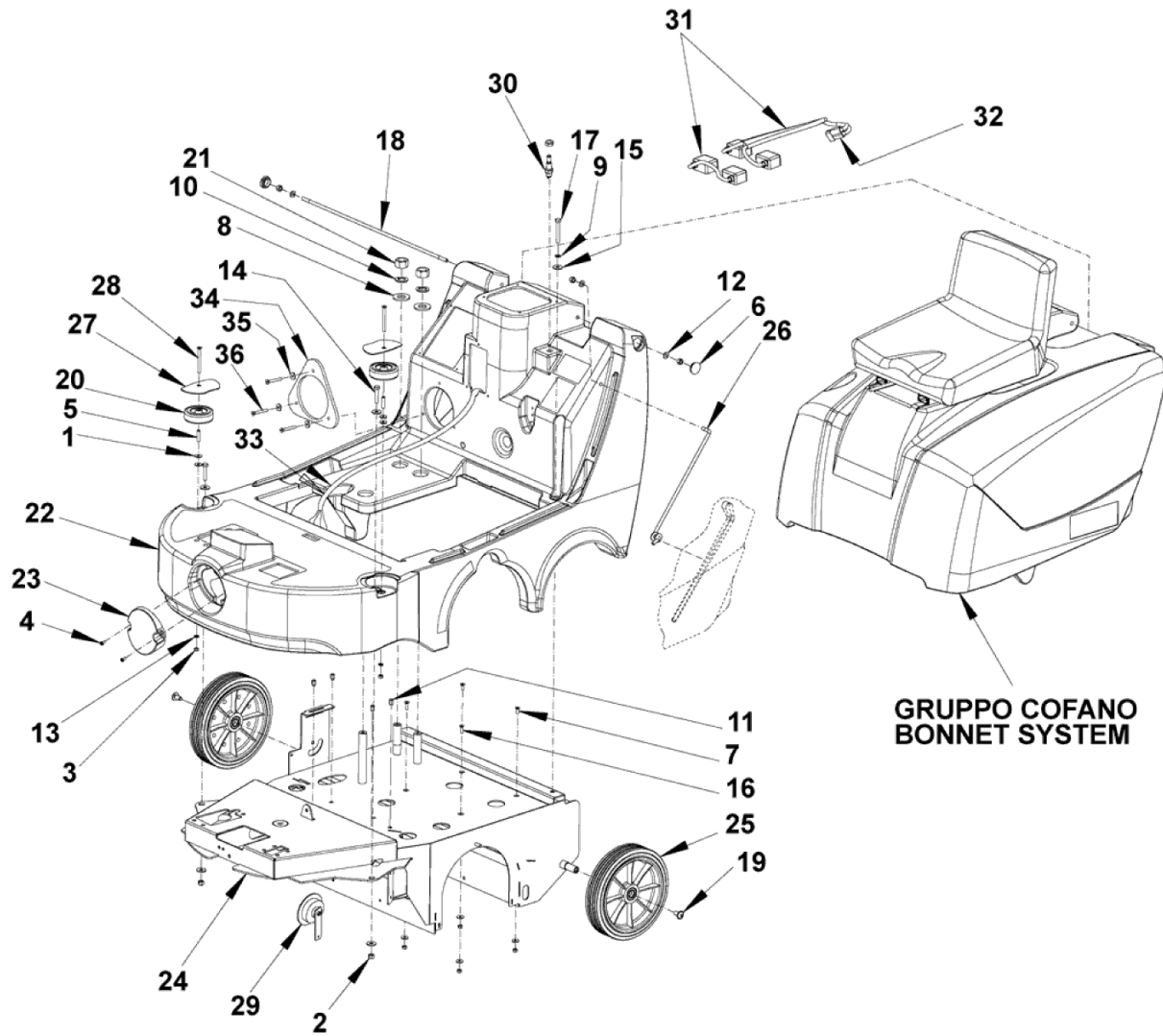

Pos.	Product no	QTY	Description	Notes
1		4	WASHER FLAT M6X18	[1]
2		5	NUT SELF LOCKING M8	[2]
3		6	NUT SELF LOCKING M6	[3]
4		2	SCREW M5X10	[4]
5		2	SPACER	[5]
6	33023302	2	PLUG FINNED D.32 PLASTIC BLACK SIP	
7		2	SCREW M6X16	[6]
8		2	WASHER FLAT M20X43	[7]
9		1	WASHER SPLIT M8	[8]
10		2	WASHER SPLIT M20	[9]
11		4	INSERT M6	[10]
12		3	WASHER FLAT M8X17	[11]
13		2	WASHER FLAT 6X12,5	[12]
14		2	SCREW M8X40	[13]
15		5	WASHER FLAT M8X24	[14]
16		2	SCREW M6X20	[15]
17		1	SCREW M8X60	[16]
18	146 0534 000	1	SHAFT. HANDLE	
19		2	SCREW M10X20	[17]
20		2	ROLLER BUMPER	[18]
21		2	HEXAGONAL NUT M20	[19]
22	146 1681 000	1	CHASSIS ROTOMOLDED GREY	
23	1465168000	1	COVER MET. BLACK FRONT LIGHT	[20]
24	146 2965 000	1	CHASSIS GALV.	[21]
25	146 1899 000	2	WHEEL D.250X50 BLACK/GREY	
26	146 1900 000	1	BAR SAFETY F BONNET MET.RED	
27	1467505000	2	PLATE COVER F ROLLER BUMPER BLACK SIP	[22]
28		2	SCREW M6X70	[23]
29	1467032000	1	HORN 24V 112DB SIP	
30	146 0565 000	1	SWITCH PUSH BUTTON	
31	1467533000	1	HARNES BATTERY KIT	
31	9097590000	1	CABLE BATTERIES BRIDGE	
32	146 1986 000	1	CONNECTOR 120A RED	
33	146 2240 000	1	HARNES MACHINE SR1000S B	
34	146 3127 000	1	GASKET	
35	33023224	1	WASHER PLAIN M10 ISO7089 10 PCS SET	
36	33004578	3	SCREW M6X20 C/SUNK FLAT HD HEX ISO10642	
K1	1464391000	1	HARDWARE CHASSIS SYST KIT	[24]
K2	1464392000	2	WHEELS BUMPER KIT	[25]

Part Notes:

- [1] - WASHER FLAT M6X18
- [2] - NUT SELF LOCKING M8
- [3] - NUT SELF LOCKING M6
- [4] - SCREW M5X10
- [5] - SPACER
- [6] - SCREW M6X16
- [7] - WASHER FLAT M20X43
- [8] - WASHER SPLIT M8
- [9] - WASHER SPLIT M20
- [10] - INSERT M6
- [11] - WASHER FLAT M8X17
- [12] - WASHER FLAT 6X12,5
- [13] - SCREW M8X40
- [14] - WASHER FLAT M8X24
- [15] - SCREW M6X20
- [16] - SCREW M8X60
- [17] - SCREW M10X20
- [18] - ROLLER BUMPER

- [19] - HEXAGONAL NUT M20
- [20] - STOCK COVERS GUARANTEE
- [21] - ITEM NO LONGER AVAILABLE
- [22] - PLATE
- [23] - SCREW M6X70
- [24] - NOT SHOWN (POS.2-3-4-7-8-9-10-11-12-13-14-15-16-17-19-21)
- [25] - NOT SHOWN (POS.1-3-5-13-20-27-28)

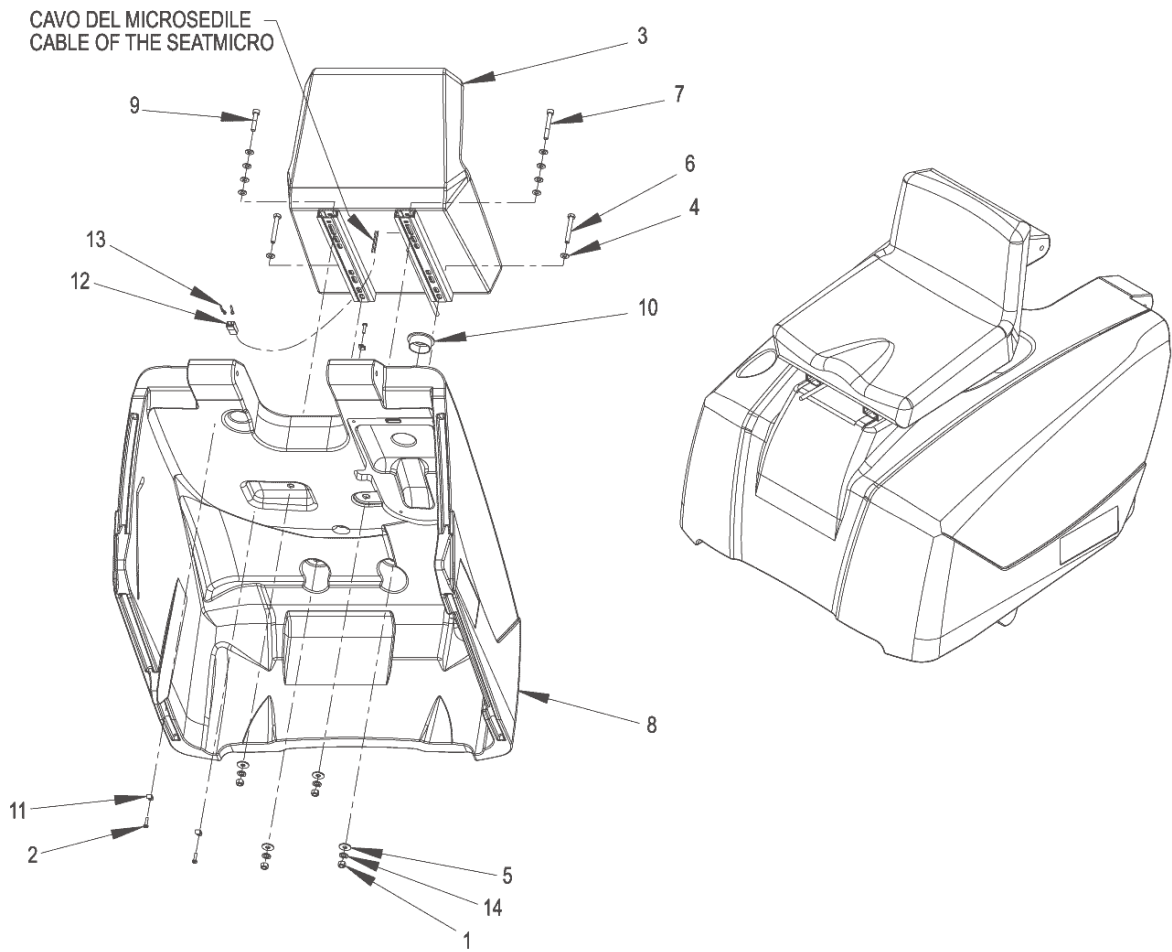

Pos.	Product no	QTY	Description	Notes
1		4	NUT HEX. M8	[1]
2		3	SCREW 4.6X19.2	[2]
3	145 1782 000	1	SEAT W/MICROSWITCH	
4		10	WASHER FLAT M8X17	[3]
5		4	WASHER FLAT M8X24	[4]
6		2	SCREW M8X60	[5]
7		1	SCREW M8X60	[5]
8	146 1682 000	1	HOOD ROTOMOLDED GREY BATTERY	
9		1	SCREW M8X40	[6]
10	146 1970 000	1	PLUG CLOSURE D.55 PLASTIC WHITE	
11		3	CABLE CLAMP	[7]
12	145 3740 000	1	TERMINAL MALE FASTON 6.3X0.8	
13	145 3733 000	1	CONNECTOR 2 WAY FASTON MALE H. 6.3X0.8	
14		4	WASHER SPLIT M8	[8]
16	1463241000	1	HARNESSE SEAT MICRO KIT	[9]
K1	1464393000	1	HARDWARE BONNET SYST KIT	[10]

Part Notes:

- [1] - NUT HEX. M8
- [2] - SCREW 4.6X19.2
- [3] - WASHER FLAT M8X17
- [4] - WASHER FLAT M8X24
- [5] - SCREW M8X60
- [6] - SCREW M8X40
- [7] - CABLE CLAMP
- [8] - WASHER SPLIT M8
- [9] - GUARANTEE DATE EXPIRED

NOT SHOWN - TSB IT 2007-012 -INST. INSTR. 1463243000

- [10] - NOT SHOWN (POS.1-2-4-5-6-7-9-11-14)

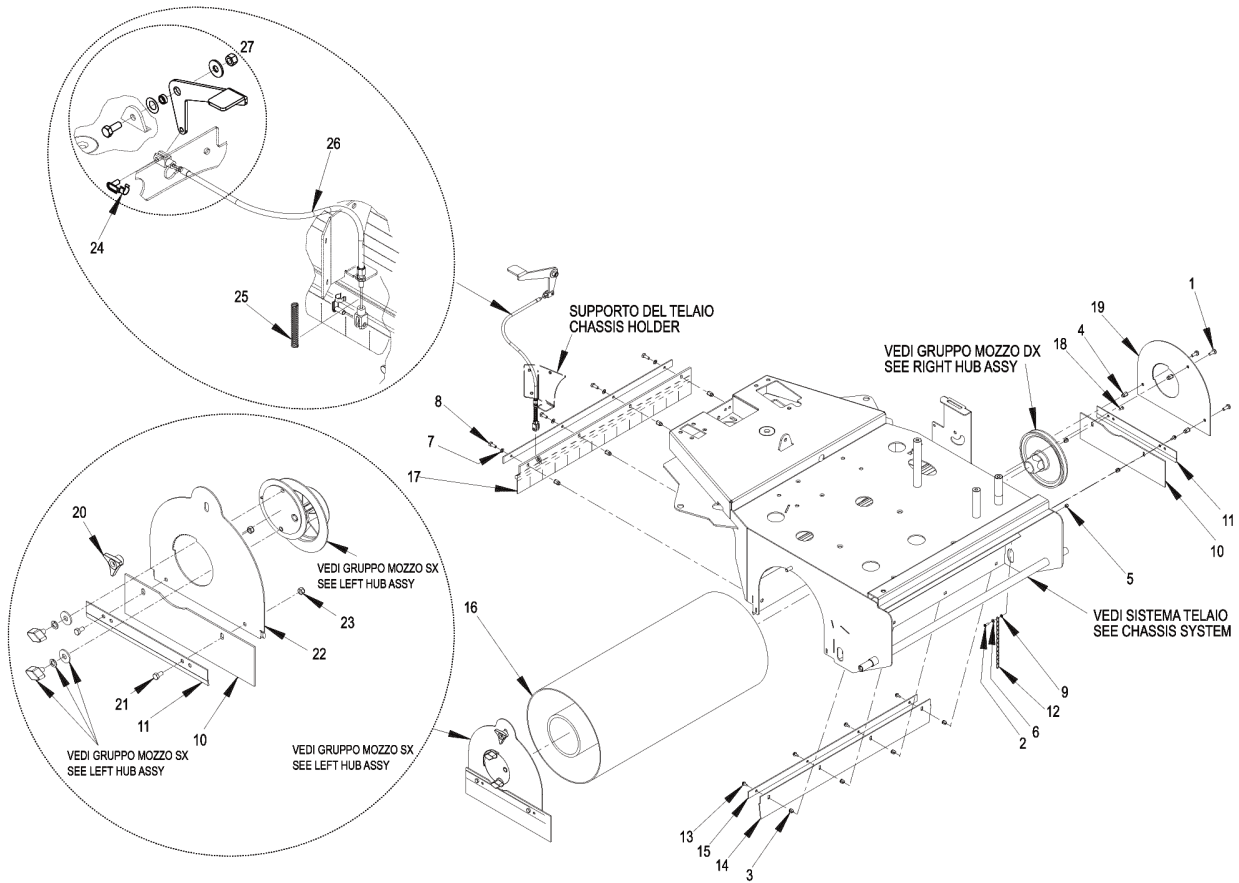

Pos.	Product no	QTY	Description	Notes
1		3	SCREW M6X16	[1]
2		1	SCREW 4X12	[2]
3		6	NUT SCREW	[3]
4		7	INSERT M6	[4]
5		1	NUT SELFLOCKING M8	[5]
6		1	WASHER FLAT 4X9	[6]
7		4	WASHER SPLIT 6	[7]
8		4	SCREW M6X16	[1]
9		1	TOOTHED WASHER 4	[8]
10	146 0555 000	2	SKIRT SIDE	
10	146 0587 000	2	SKIRT SIDE NON MARKING	
11	146 0557 000	2	PLATE SIDE SKIRT MET. GREY	
12	146 0611 000	1	CHAIN GROUND KIT	
13		5	SCREW 3,9X13	[9]
14	146 0743 000	1	SKIRT REAR NON MARKING	
14	146 0738 000	1	SKIRT REAR	
15	146 0739 000	2	PLATE FRONT SKIRT MET. GREY	
16	146 0748 000	1	BROOM MAIN 265X600 CHEVRON 6R PPL 0.7	
16	146 0749 000	1	BROOM MAIN 265X600 CHEVRON 6R NATURAL	[10]
16	146 0750 000	1	BROOM MAIN 265X600 CHEVRON 6R MIX STEEL	
16	146 0753 000	1	BROOM MAIN 245X600 CHEVRON 6R NATURAL	
17	146 0756 000	1	SKIRT FRONT SOFT	
18		1	SCREW 3.9X13	[11]
19	146 2137 000	1	HATCH RT CLOSING MAIN BROOM SPACE GREY	
20	145 5035 000	1	KNOB LOBES M8 FEMALE	
21		2	SCREW HEX. M6X12	[12]
22	1466363000	1	HATCH LT MET. GREY F MAIN BROOM SIP	
23		2	NUT HEX. SELFLOCK. M6	[13]
24	145 4536 000	2	SPRING PIN M6X12 GALV	
25	145 1935 000	1	SPRING COMPRESSION D.E.9 WIRE D.1	
26	145 1975 000	1	CABLE SKIRT RAIS.DEVICE	
27	146 2161 000	2	PEDAL SKIRT RAISING DEVICE KIT	
28	1464395000	1	HUB LEFT KIT	
29	1464396000	1	HUB RIGHT KIT	
K1	1464394000	1	HARDWARE MAIN BROOM KIT	[14]

Part Notes:

- [1] - SCREW M6X16
- [2] - SCREW 4X12
- [3] - NUT SCREW
- [4] - INSERT M6
- [5] - NUT SELFLOCKING M8
- [6] - WASHER FLAT 4X9
- [7] - WASHER SPLIT 6
- [8] - TOOTHED WASHER 4
- [9] - SCREW 3,9X13
- [10] - PI 2015-001 TTY
- [11] - SCREW 3.9X13
- [12] - SCREW HEX. M6X12
- [13] - NUT HEX. SELFLOCK. M6
- [14] - NOT SHOWN (POS.1-2-3-4-5-6-7-8-9-13-18-21-23)

**KIT GRUPPO MOZZO SX
LEFT HUB ASSEMBLY KIT**

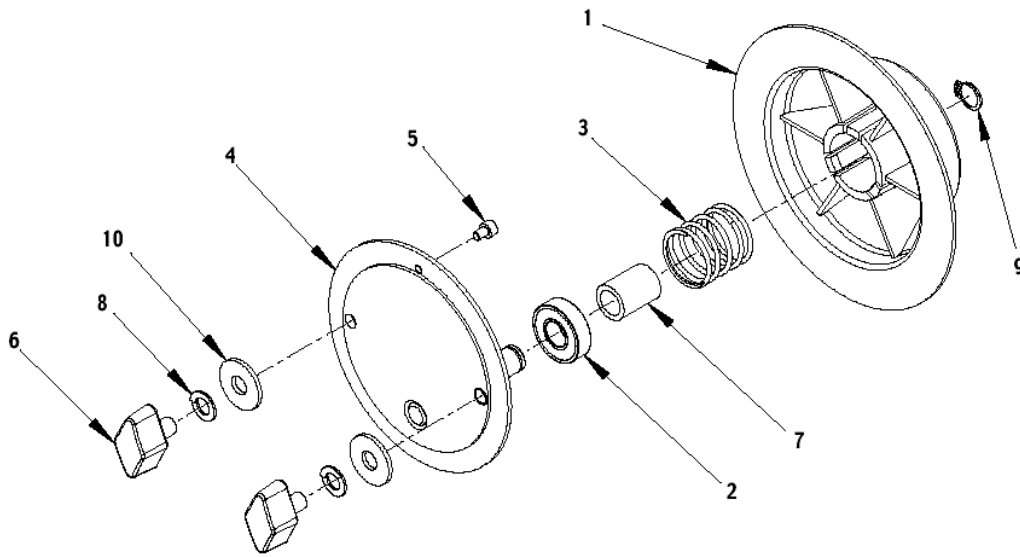

**KIT GRUPPO MOZZO DX
RIGHT HUB ASSEMBLY KIT**

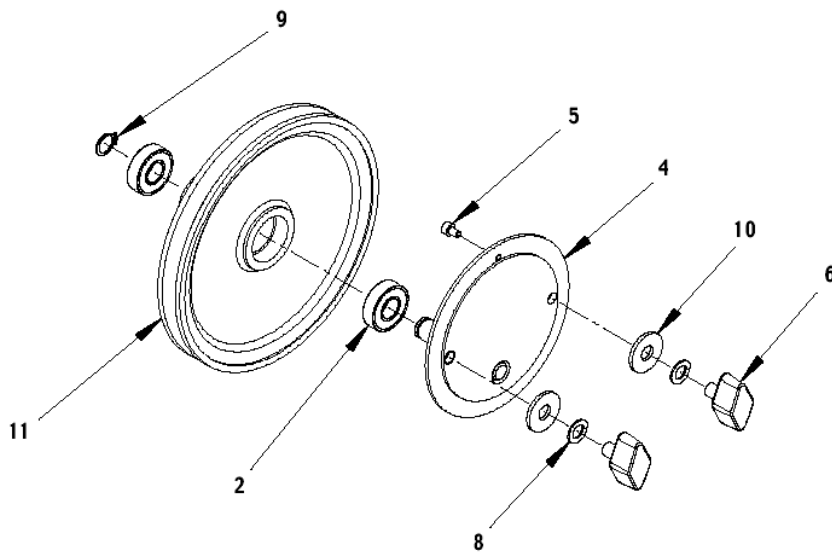

Pos.	Product no	QTY	Description	Notes
1		1	LEFT HUB	[1]
2		3	BALL BEARING	[2]
3		1	SPRING	[3]
4		2	PIN	[4]
5		2	SCREW HEX HD M4X6	[5]
6		4	KNOB	[6]
7		1	SPACER	[7]
8		4	WASHER	[8]
9		2	RETAINING RING	[9]
10		4	WASHER FLAT	[10]
11		1	PULLEY	[11]
K1	1464395000	1	HUB LEFT KIT	[12]
K2	1464396000	1	HUB RIGHT KIT	[13]

Part Notes:

- [1] - LEFT HUB
- [2] - BALL BEARING
- [3] - SPRING
- [4] - PIN
- [5] - SCREW HEX HD M4X6
- [6] - KNOB
- [7] - SPACER
- [8] - WASHER
- [9] - RETAINING RING
- [10] - WASHER FLAT
- [11] - PULLEY
- [12] - NOT SHOWN (POS.1-2-3-4-5-6-7-8-9-10)
- [13] - NOT SHOWN (POS.2-4-5-6-8-9-10-11)

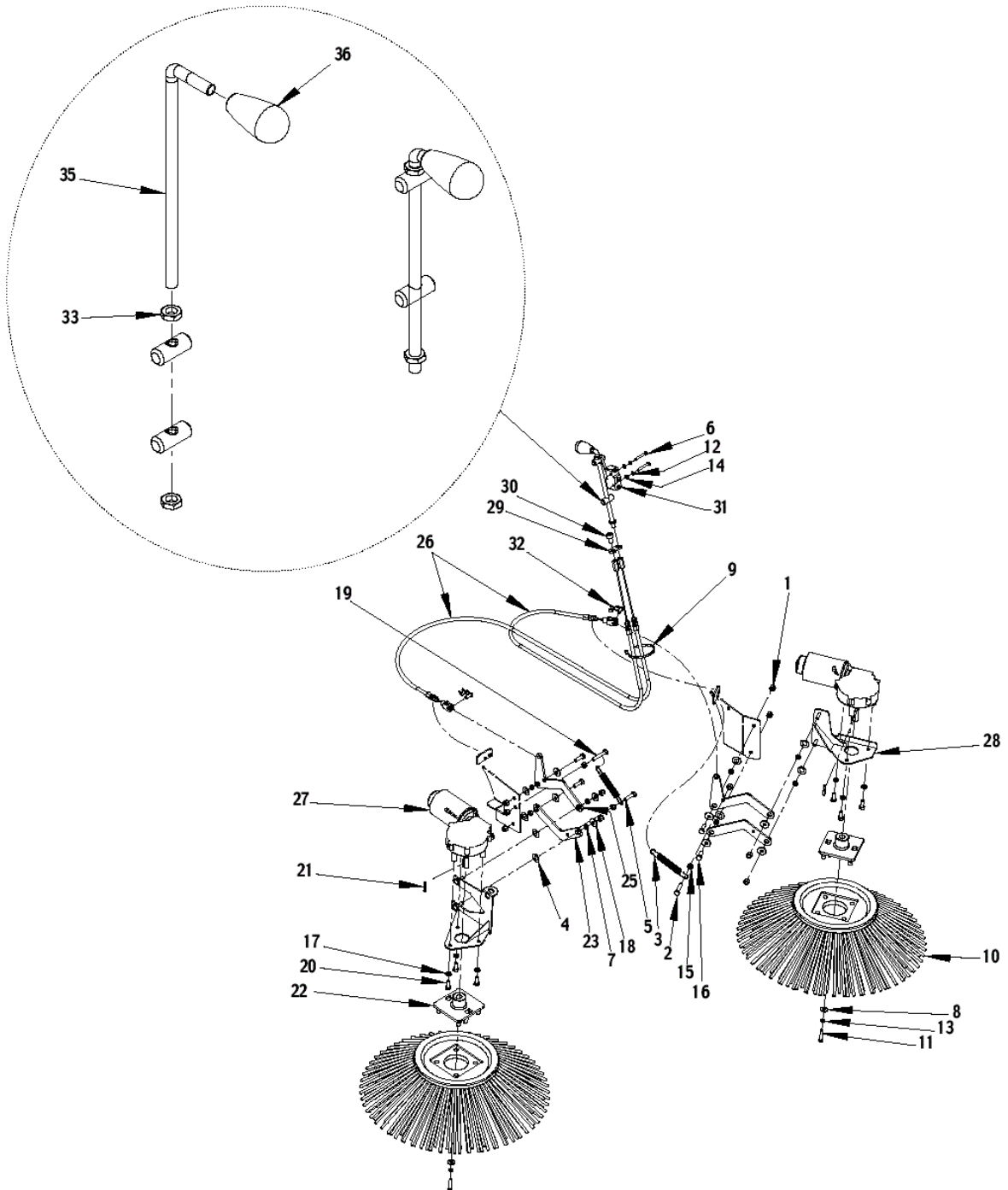

Pos.	Product no	QTY	Description	Notes
1		10	NUT SELF LOCKING M6	[1]
2		1	SCREW M6X30	[2]
3	145 0274 000	2	SPRING EXTENSION D.E.12 WIRE D.1.5	
4	145 1147 000	8	BELLEVILLE WASHER 10.2X18.8X0.35 DIN2093	
5		1	SCREW M6X25	[3]
6		2	SCREW M4X30	[4]
7		8	SPACER	[5]
8		2	WASHER FLAT 5X15	[6]
9		1	CLAMP 3.6X140	[7]
10	145 4959 000	2	BROOM SIDE 180X400 MIX STEEL	
10	146 0678 000	2	BROOM SIDE 180X350 NYLON	[8]
10	145 4976 000	2	BROOM SIDE 180X400 NATURAL	[8]
10	145 1899 000	2	BROOM SIDE 180X400 PPL 0.7	[8]
11		2	SCREW M5X25	[9]
12		2	WASHER SPLIT	[10]
13		2	WASHER SPLIT	[10]
14		2	WASHER FLAT M4X9	[11]
15		3	NUT M6	[12]
16		4	SCREW M6X20	[13]
17		6	WASHER SPLIT	[10]
18		8	WASHER FLAT M6X18	[14]
19		1	SCREW M6X35	[15]
20		6	SCREW M6X16	[16]
21		2	KEY	[17]
22	146 0519 000	2	HUB SIDE BROOM	
23	146 0558 000	2	ARM SIDE BROOM	
25	146 1894 000	2	ARM UPPER SIDER BROOM	
26	146 1895 000	2	CABLE SIDE BROOM L.1217MM	[18]
27	1464152000	2	REDUCTION GEARMOTOR 60W 24V	
27	1464166000	1	CARBON BRUSHES W/HOLDER KIT	[19]
27	1464054000	1	CARBON BRUSHES W/HOLDER KIT	[20]
28	146 2972 000	1	BRACKET SIDE BROOM GALV.	
29	146 2107 000	1	PLATE	[18]
30		1	SCREW M8X12	[21]
31	1466506000	1	MICROSWITCH 15A 250V SIP	
32	145 4536 000	2	SPRING PIN M6X12 GALV	
33		2	NUT M8	[22]
35	146 1955 000	1	PIN	[18]
36	145 9319 000	1	KNOB M8	[18]
K1	146 2226 000	1	HARDWARE SIDE BROOM KIT	[23]

Part Notes:

- [1] - NUT SELF LOCKING M6
- [2] - SCREW M6X30
- [3] - SCREW M6X25
- [4] - SCREW M4X30
- [5] - SPACER
- [6] - WASHER FLAT 5X15
- [7] - CLAMP 3.6X140
- [8] - OPTIONAL
- [9] - SCREW M5X25
- [10] - WASHER SPLIT
- [11] - WASHER FLAT M4X9
- [12] - NUT M6
- [13] - SCREW M6X20
- [14] - WASHER FLAT M6X18
- [15] - SCREW M6X35
- [16] - SCREW M6X16
- [17] - KEY

- [18] - GUARANTEE DATE EXPIRED
- [19] - NOT SHOWN - FOR NEW RED.GEAR MOT.1464152000
- [20] - GUARANTEE DATE EXPIRED
NOT SHOWN - FOR OLD RED.GEAR MOT.146 1897 000
See TSB IT 2009-033
- [21] - SCREW M8X12
- [22] - NUT M8
- [23] - GUARANTEE DATE EXPIRED
NOT SHOWN (POS.1-2-5-6-7-8-9-11-12-13-14-15-16-17-18-19-20-21-30-33)

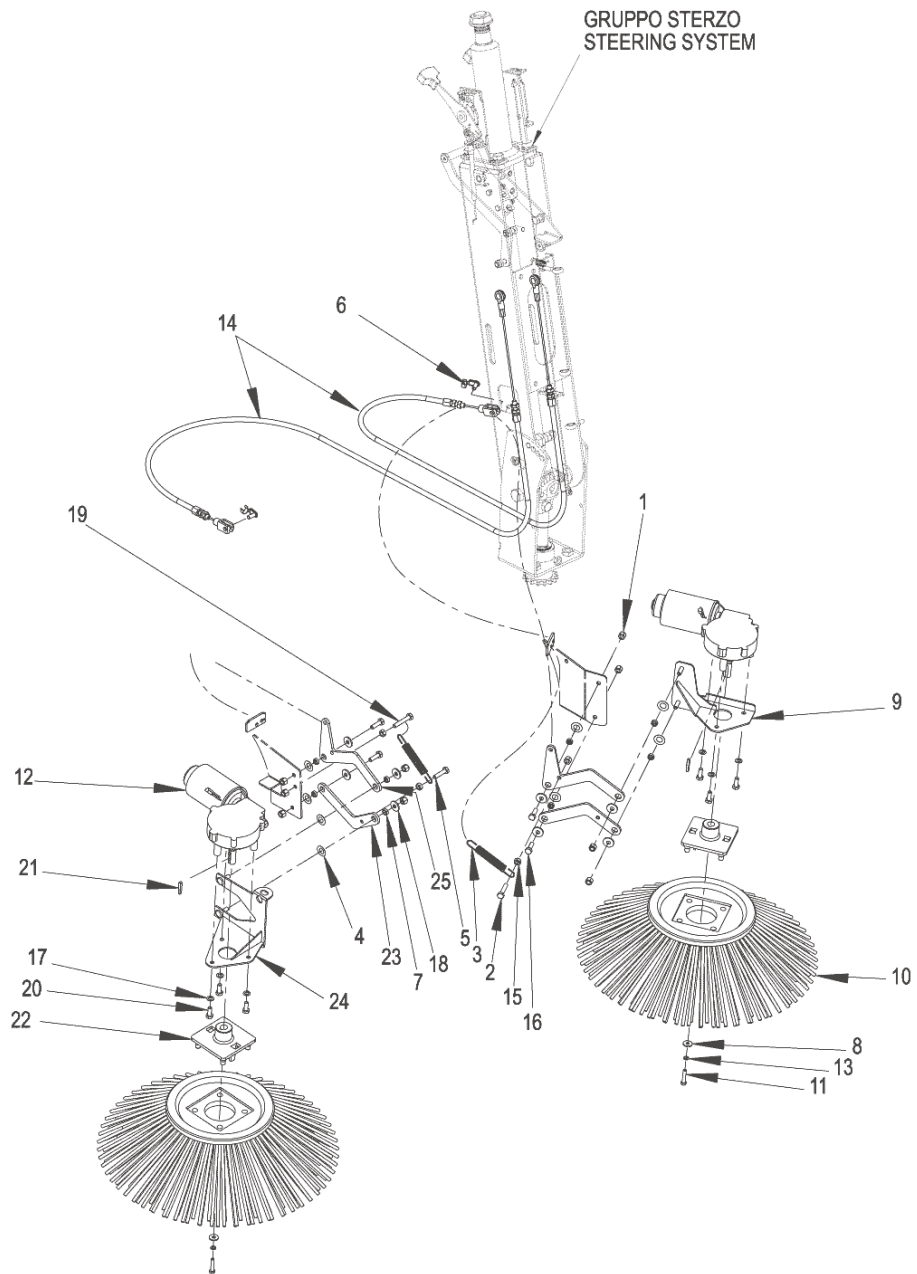

Pos.	Product no	QTY	Description	Notes
1		10	NUT SELF LOCKING M6	[1]
2		1	SCREW M6X30	[2]
3	145 0274 000	2	SPRING EXTENSION D.E.12 WIRE D.1.5	
4	145 1147 000	8	BELLEVILLE WASHER 10.2X18.8X0.35 DIN2093	
5		1	SCREW M6X25	[3]
6	145 4536 000	2	SPRING PIN M6X12 GALV	
7		8	SPACER	[4]
8		2	WASHER FLAT 5X15	[5]
9	146 2972 000	1	BRACKET SIDE BROOM GALV.	
10	145 4959 000	2	BROOM SIDE 180X400 MIX STEEL	
10	145 1899 000	2	BROOM SIDE 180X400 PPL 0.7	[6]
10	145 4976 000	2	BROOM SIDE 180X400 NATURAL	[6]
10	146 0678 000	2	BROOM SIDE 180X350 NYLON	[6]
11		2	SCREW M5X25	[7]
12	1464152000	2	REDUCTION GEARMOTOR 60W 24V	[8]
12	1464166000	1	CARBON BRUSHES W/HOLDER KIT	[9]
12	1464054000	1	CARBON BRUSHES W/HOLDER KIT	[10]
13		2	WASHER SPLIT	[11]
14	146 2970 000	2	CABLE SIDE BROOMS L.1345MM	
15		3	NUT M6	[12]
16		4	SCREW M6X20	[13]
17		6	WASHER SPLIT	[11]
18		8	WASHER FLAT M6X18	[14]
19		1	SCREW M6X35	[15]
20		6	SCREW M6X16	[16]
21		2	KEY	[17]
22	146 0519 000	2	HUB SIDE BROOM	
23	146 0558 000	2	ARM SIDE BROOM	
24	146 2971 000	1	BRACKET. SIDE BROOM	
25	146 1894 000	2	ARM UPPER SIDER BROOM	
K1	1464397000	1	HARDWARE SIDE BROOMS KIT	[18]

Part Notes:

- [1] - NUT SELF LOCKING M6
- [2] - SCREW M6X30
- [3] - SCREW M6X25
- [4] - SPACER
- [5] - WASHER FLAT 5X15
- [6] - OPTIONAL
- [7] - SCREW M5X25
- [8] - FROM SN.092816281
- [9] - FOR NEW RED.GEAR MOT.1464152000
- [10] - FOR OLD RED.GEAR MOT.146 1897 000
GUARANTEE DATE EXPIRED
See TSB IT 2009-033
- [11] - WASHER SPLIT
- [12] - NUT M6
- [13] - SCREW M6X20
- [14] - WASHER FLAT M6X18
- [15] - SCREW M6X35
- [16] - SCREW M6X16
- [17] - KEY
- [18] - NOT SHOWN (POS.1-2-5-6-7-8-9-11-12-13-14-15-16-17-18-19-20-21-30-33)

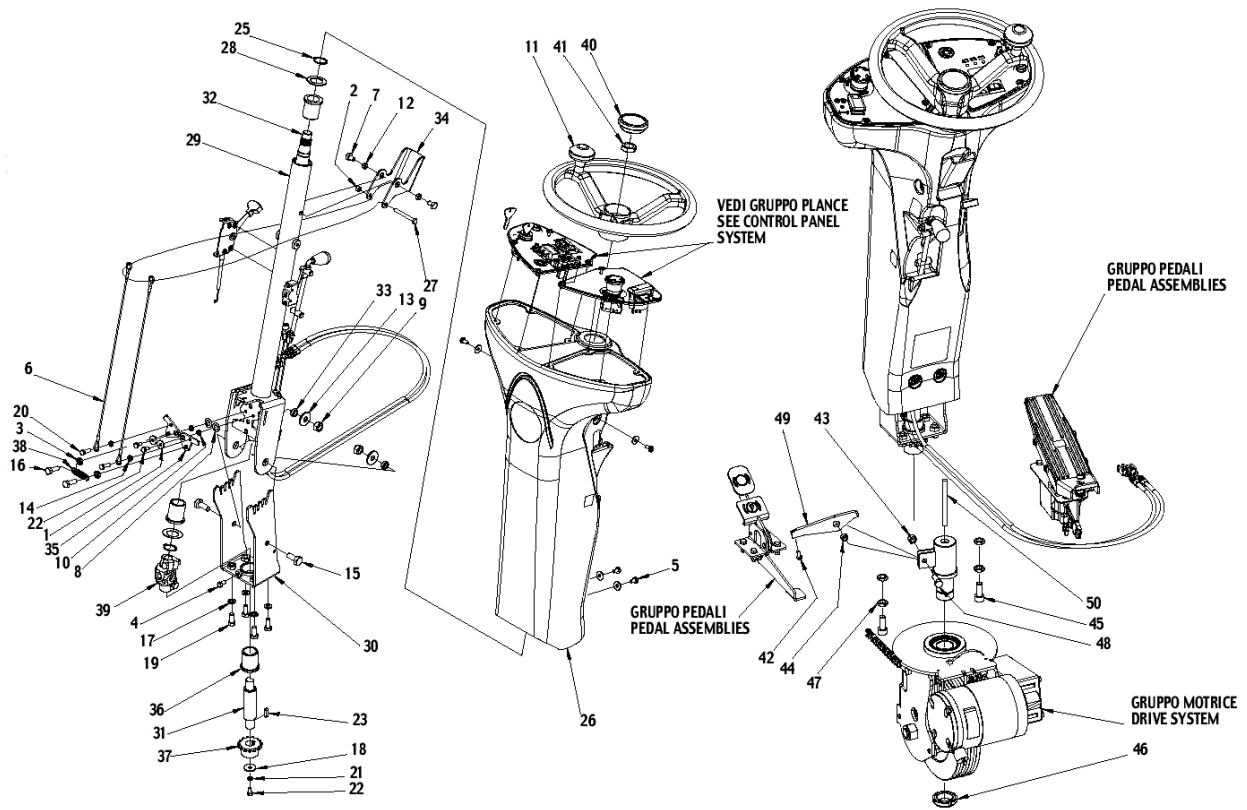

Pos.	Product no	QTY	Description	Notes
1		6	WASHER M6X18	[1]
2		1	NUT SELF LOCKING M6	[2]
3		2	NUT M8	[3]
4		1	SCREW M6X16	[4]
5		4	SCREW M6X12	[5]
6	L08812362	2	CABLE SQUEEGEE LIFTING L.420MM	[6]
7		2	SCREW M8X12	[7]
8		2	SPRING	[8]
9		2	NUT SELFLOCKING M10	[9]
10		2	SPACER	[10]
11	146 2106 000	1	STEERING WHEEL D.320 TAPER 1/19.26	
12		2	SPACER	[10]
13		2	WASHER M10X30	[11]
14		2	NUT M6	[12]
15		2	SCREW M10X25	[13]
16		2	SCREW M8X25	[14]
17	146 1886 000	1	PIN	[15]
18		1	WASHER M6X24	[16]
19		4	SCREW M8X16	[17]
20		2	SCREW M6X20	[18]
21		1	WASHER	[19]
22		3	SCREW M6X12	[5]
23		1	KEY	[20]
25		2	RETAINING RING	[21]
27		1	SCREW M6X55	[22]
28		1	SPACER	[10]
29	146 1906 000	1	steering column	[15]
30	146 1907 000	1	SUPPORT. STEERING COLUMN	[15]
31	146 1908 000	1	SHAFT.PINION STEERING	[15]
32	146 1909 000	1	SHAFT STEERING PHOS.	[15]
33		2	SPACER	[10]
34	146 1911 000	1	LEVER	[15]
35	146 1912 000	2	LEVER	[15]
36	146 1913 000	3	BEARING FLANGE IGLIDUR MFM-2532-40	[15]
37	145 2601 000	1	SPROCKET T15 3/8	[15]
38		1	SPRING	[8]
39	1466319000	1	JOINT UNIVERSAL D.17 SIP	
40	1467031000	1	CAP SIP	
41		1	NUT M8X1,5	[23]
42		1	SCREW M5X12 SS	[24]
43		1	NUT M8	[3]
44		1	SPACER	[10]
45		2	SCREW M10X25	[13]
46		1	NUT RING SELFLOCKING	[25]
47		4	NUT M10	[26]
48		1	SCREW M8X25	[14]
49	146 1885 000	1	LEVER	[15]
K1	146 2227 000	1	HARDWARE STEERING KIT SR 1000S	[15]

Part Notes:

- [1] - WASHER M6X18
- [2] - NUT SELF LOCKING M6
- [3] - NUT M8
- [4] - SCREW M6X16
- [5] - SCREW M6X12
- [6] - Till S/N 062211240
- [7] - SCREW M8X12
- [8] - SPRING
- [9] - NUT SELFLOCKING M10

- [10] - SPACER
- [11] - WASHER M10X30
- [12] - NUT M6
- [13] - SCREW M10X25
- [14] - SCREW M8X25
- [15] - GUARANTEE DATE EXPIRED
- [16] - WASHER M6X24
- [17] - SCREW M8X16
- [18] - SCREW M6X20
- [19] - WASHER
- [20] - KEY
- [21] - RETAINING RING
- [22] - SCREW M6X55
- [23] - NUT M8X1,5
- [24] - SCREW M5X12 SS
- [25] - NUT RING SELFLOCKING
- [26] - NUT M10

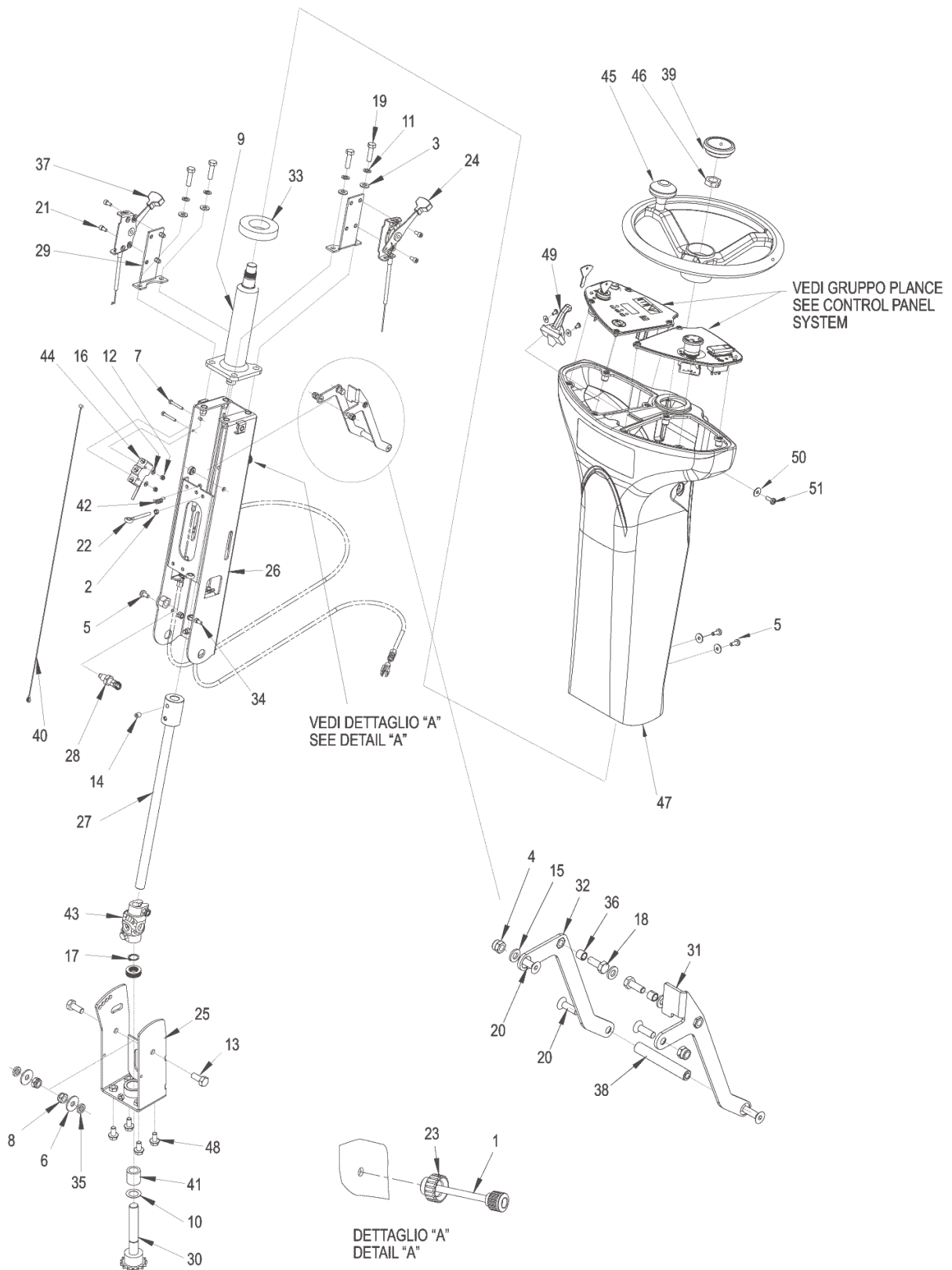

Pos.	Product no	QTY	Description	Notes
1	145 1354 000	1	KNOB KNURLED M6X65 MALE	
2		4	NUT HEX M5	[1]
3		4	WASHER FLAT 8X17	[2]
4		3	NUT HEX SELFLOCK. M6	[3]
5		5	SCREW M6X12	[4]
6		2	WASHER FLAT 10X30	[5]
7		2	SCREW HEX HD M4X30	[6]
8		2	NUT	[7]
9	1466525000	1	COLUMN STEERING SIP	
10		7	SPRING	[8]
11		4	WASHER SPLIT 8	[9]
12		2	NUT	[7]
13		2	SCREW	[10]
14		1	SCR, SOC SET	[11]
15		3	WASHER FLAT 6X12,5	[12]
16		2	WASHER FLAT 4X9	[13]
17	9100001345	1	RING D 17 UNI7435 10 PCS SET	
18		2	SCREW HEX. HD M6X16	[14]
19		4	SCREW HEX HD M8X25	[15]
20		4	SCREW M6X20	[16]
21		4	SCREW M5X10	[17]
22	146 2450 000	1	TIE-ROD EYE D.8 M5X52MM GALV.	
23	1466374000	1	KNOB KNURLED M6 FEMALE SIP	
24	146 2939 000	1	LEVER W/CABLE F PARKING BRAKE	
25	146 2945 000	1	SUPPORT STEERING COLUMN GALV.	
26	146 2947 000	1	STEERING COLUMN MET.	
27	146 2948 000	1	SHAFT STEERING UPPER KIT	
28	1466328000	1	PLUNGER M12 D.8 W/NUT SIP	
29	146 2951 000	2	SUPPORT VACUUM CABLE ZNT	
30	146 2953 000	1	SHAFT STEERING LOWER W/PINION PHOS.	
31	146 2954 000	1	LEVER LT SIDE BROOM GALV.	
32	146 2955 000	1	LEVER RT SIDE BROOM GALV.	
33	146 2956 000	1	GASKET STEERING SYSTEM	
34	146 2957 000	2	TIE-ROD EYE D.8 M5X25MM GALV.	
35		2	SPACER	[18]
36	146 2959 000	2	BEARING SLEEVE PAP 06 08 P10	
37	146 2960 000	1	LEVER W/CABLE F VAC CONTROL	
38	146 2961 000	1	HANDLE SIDE BROOMS GALV.	
39	1467031000	1	CAP SIP	
40	1466327000	1	PLUNGER M12 W/CABLE KIT	[19]
41	145 9505 000	1	BUSHING BBB 17X25X25	
42	145 9290 000	1	SPRING EXTENTION D.E.8.2 WIRE D.0.8	
43	1466319000	1	JOINT UNIVERSAL D.17 SIP	
44	1466506000	1	MICROSWITCH 15A 250V SIP	
45	146 2106 000	1	STEERING WHEEL D.320 TAPER 1/19.26	
46		1	NUT HEX LOW M18X1.5	[20]
47	146 2906 000	1	COVER ROTOMOLDED FRONT	
48	146 2316 000	4	SCREW M8X16 HEX HD F/THD FLANG ISO1665	
49	146 2458 000	1	LEVER PLASTIC STEERING WHEEL ADJUSTMENT	
50		4	WASHER FLAT 6X18	[21]
51		4	SCR, PAN PHIL M6X16	[22]
K1	1464398000	1	HARDWARE STEERING KIT	[23]

Part Notes:

- [1] - NUT HEX M5
- [2] - WASHER FLAT 8X17
- [3] - NUT HEX SELFLOCK. M6
- [4] - SCREW M6X12
- [5] - WASHER FLAT 10X30

- [6] - SCREW HEX HD M4X30
- [7] - NUT
- [8] - SPRING
- [9] - WASHER SPLIT 8
- [10] - SCREW
- [11] - SCR, SOC SET
- [12] - WASHER FLAT 6X12,5
- [13] - WASHER FLAT 4X9
- [14] - SCREW HEX. HD M6X16
- [15] - SCREW HEX HD M8X25
- [16] - SCREW M6X20
- [17] - SCREW M5X10
- [18] - SPACER
- [19] - Included pos. 28
- [20] - NUT HEX LOW M18X1.5
- [21] - WASHER FLAT 6X18
- [22] - SCR, PAN PHIL M6X16
- [23] - NOT SHOWN (POS.1-2-3-4-5-6-7-8-10-11-12-13-14-15-16-18-19-20-21-35-46-50-51)

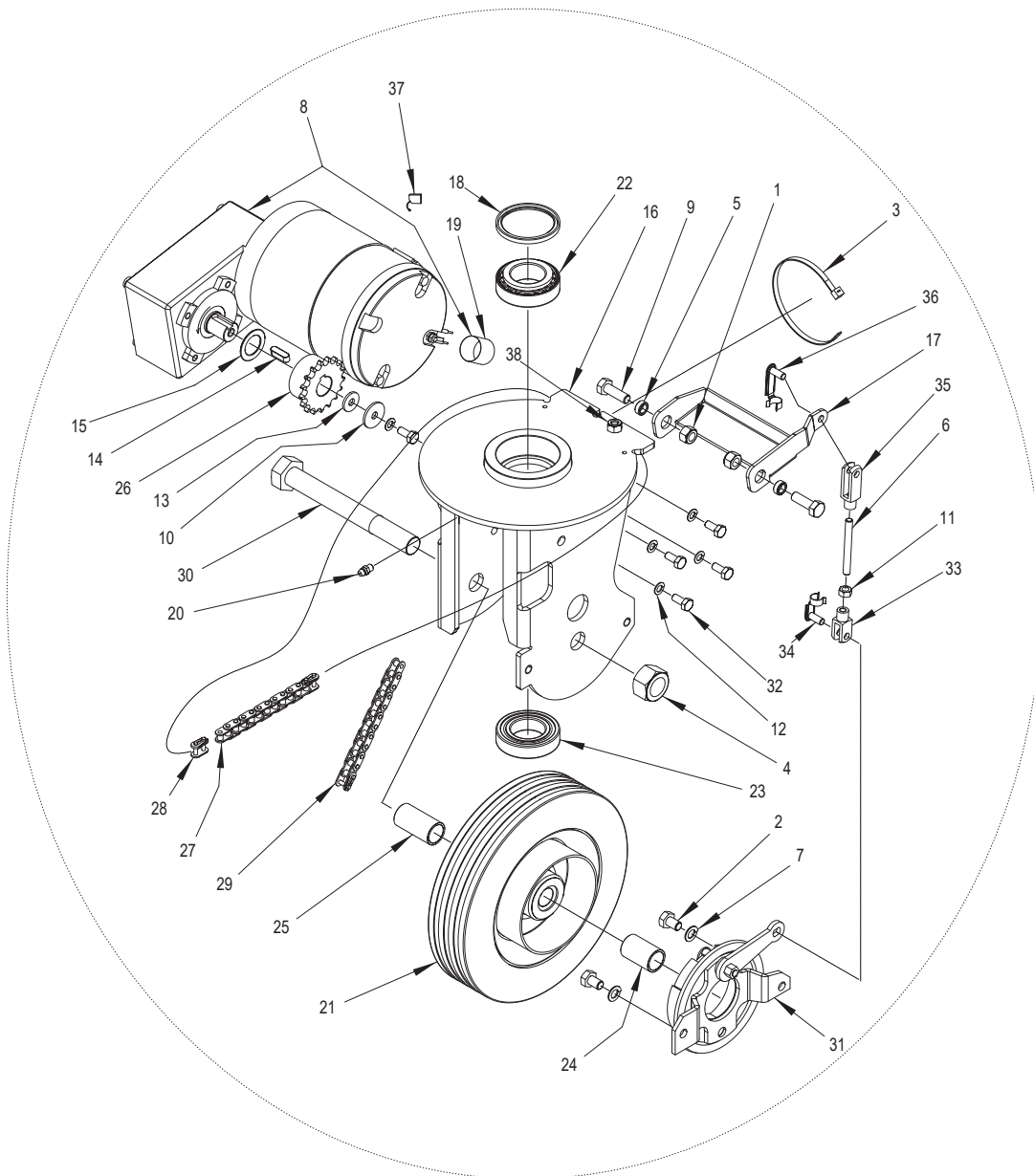

Pos.	Product no	QTY	Description	Notes
1		2	NUT SELFLOCKING M8	[1]
2		2	SCREW M8X12	[2]
3	909 5896 000	1	CLAMP HOSE D.12	
4		1	NUT SELFLOCKING M18	[3]
5		2	SPACER	[4]
6	145 2529 000	1	ROD THREADED M6X55MM	[5]
7		2	WASHERSPLIT M8	[6]
8	146 2166 000	1	REDUCTION GEARMOTOR 4000W 24V KIT	
9		2	SCREW M8X25	[7]
10		1	WASHER FLAT M6X24	[8]
11		1	NUT M6	[9]
12		5	WASHER SPLIT 6	[10]
13		1	WASHER FLAT 6X18	[11]
14		1	KEY 6X6X20	[12]
15		1	SPACER	[4]
16	146 1926 000	1	SUPPORT FRONT WHEEL	[5]
17	146 1927 000	1	BRACKET	[5]
18	146 1928 000	1	GASKET	[5]
19	146 1929 000	1	SHEATH	
20		1	GREASER NIPPLE M6	[13]
21	1463184000	1	WHEEL FRONT KIT	[14]
22	1467636000	1	BEARING TAPER ROLLER 32006 SIP	[15]
23	145 0225 000	1	BEARING BALL 6006 2RS1	
24	145 2574 000	1	SPACER D.17.3X21.3 H.33 GALV.	
25	145 2575 000	1	SPACER D.17.3X21.3 H.41 GALV.	
26	145 0221 000	1	SPROCKET T17 3/8-7/32	
27	145 2713 000	1	CHAIN ROLLER 3/8-59 P.+CL	[16]
28	145 9604 000	1	LINK CONNECTING 3/8	[5]
29	145 0222 000	1	CHAIN ROLLER 3/8-35 P.+HL+CL	
30	145 2576 000	1	PIN GALV. F FRONT WHEEL	
31	1466518000	1	BRAKE FRONT WHEEL SIP	
32	1466517000	1	SCREW M6X14 HEX HD ISO4017 10 PCS SETSCREW M6X14	[17]
33	145 4535 000	1	CLEVIS M6X12 GALV. DIN71752	[5]
34	145 4536 000	1	SPRING PIN M6X12 GALV	
35	1467516000	1	CLEVIS M6X24 GALV. DIN71752 SIP	
36	145 9410 000	1	SPRING PIN M6X24 GALV.	
37	1464432000	1	CARBON BRUSH 4 PCS SET	
38	8361400	1	NUT SELF L. M6 UNI7474	
K1	146 2229 000	1	HARDWARE DRIVE KIT	[18]

Part Notes:

- [1] - NUT SELFLOCKING M8
- [2] - SCREW M8X12
- [3] - NUT SELFLOCKING M18
- [4] - SPACER
- [5] - GUARANTEE DATE EXPIRED
- [6] - WASHERSPLIT M8
- [7] - SCREW M8X25
- [8] - WASHER FLAT M6X24
- [9] - NUT M6
- [10] - WASHER SPLIT 6
- [11] - WASHER FLAT 6X18
- [12] - KEY 6X6X20
- [13] - GREASER NIPPLE M6
- [14] - TSB IT 2007-025
- [15] - Till S/N 06221124
- [16] - NO LONGER AVAILABLE
- [17] - STOCK COVERS GUARANTEE
- [18] - NOT SHOWN (POS.1-2-4-5-7-9-10-11-12-13-14-15-20-32-38)

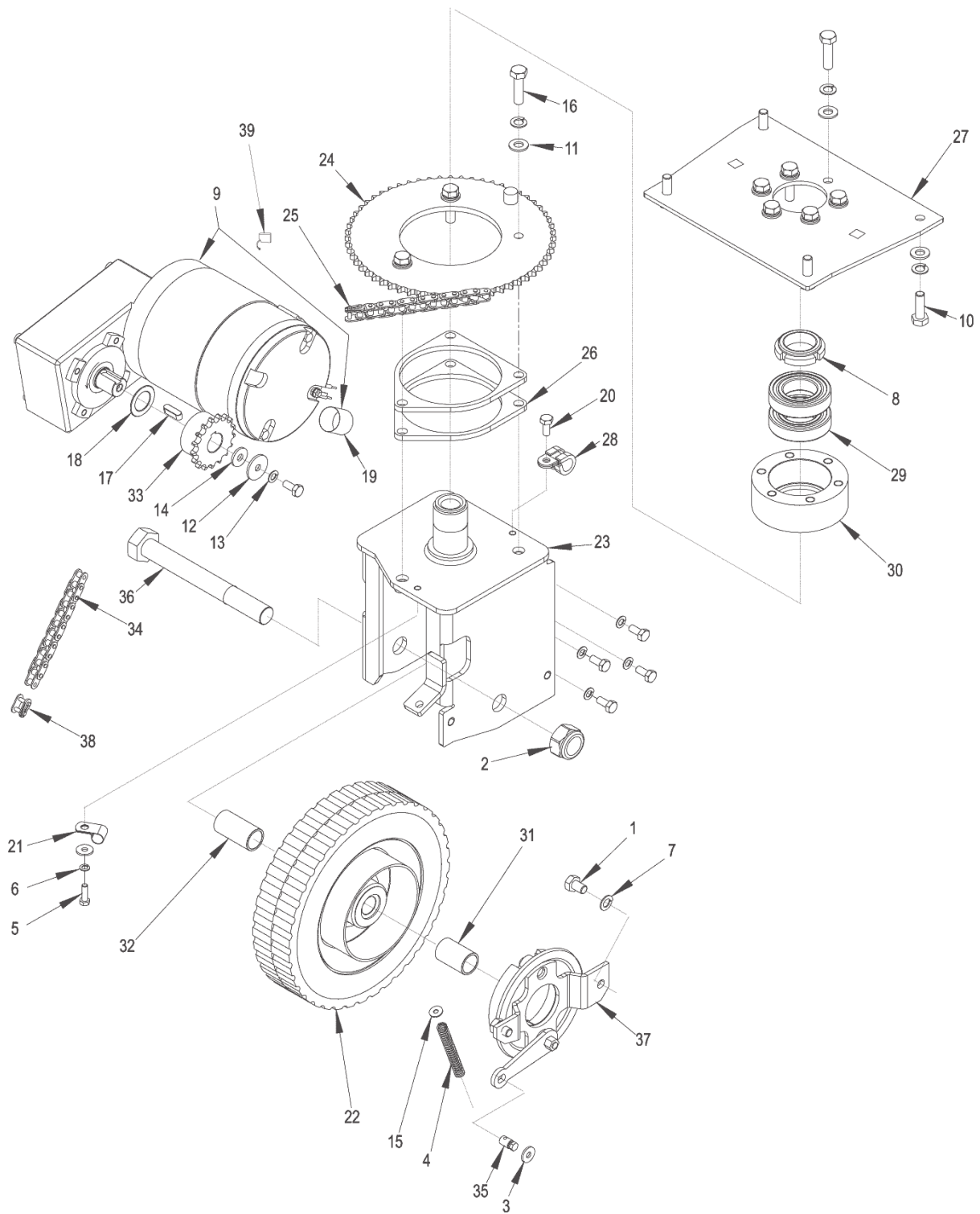

Pos.	Product no	QTY	Description	Notes
1		2	SCREW M8X12	[1]
2		1	NUT SELFLOCKING M18	[2]
3		2	WASHER	[3]
4	1467850000	1	SPRING COMPRESSION D.E.9 WIRE D.1 SIP	
5		1	SCREW HEX HD M5X16	[4]
6		1	WASHER	[3]
7		15	WASHER SPLIT 8	[5]
8		1	NUT RING SELFLOCKING	[6]
9	146 2166 000	1	REDUCTION GEARMOTOR 4000W 24V KIT	
10		4	SCREW HEX HD M8X25	[7]
11		13	WASHER FLAT 8X17	[8]
12		1	WASHER FLAT 6X24	[9]
13		5	WASHER SPLIT 6	[10]
14		1	WASHER FLAT 6X18	[11]
15		1	WASHER FLAT 4X12	[12]
16		9	SCREW HEX HD M8X30	[13]
17		1	KEY	[14]
18		1	SPACER	[15]
19	146 1929 000	1	SHEATH	
20		6	SCREW HEX HD 6X14	[16]
21	146 2417 000	1	CLAMP D. 10	
22	1463184000	1	WHEEL FRONT KIT	[17]
23	1464456000	1	SUPPORT FRONT WHEEL	
24	146 2935 000	1	SPROCKET T60 3/8	
25	145 1784 000	1	CHAIN ROLLER 3/8-67 P.+HL+CL	
26	146 2937 000	2	SPACER GALV. F STEERING SPROCKET WHEEL	
27	146 2938 000	1	PLATE GALV. F SUPPORT FRONT WHEEL	
28	909 5896 000	1	CLAMP HOSE D.12	
29	145 0225 000	2	BEARING BALL 6006 2RS1	
30	145 2568 000	1	FLANGE GALV. F BEARING HOLDER	
31	145 2574 000	1	SPACER D.17.3X21.3 H.33 GALV.	
32	145 2575 000	1	SPACER D.17.3X21.3 H.41 GALV.	
33	145 0221 000	1	SPROCKET T17 3/8-7/32	
34	145 0222 000	1	CHAIN ROLLER 3/8-35 P.+HL+CL	
35	145 9366 000	1	HOLDFAST CABLE D.3	
36	145 2576 000	1	PIN GALV. F FRONT WHEEL	
37	1466518000	1	BRAKE FRONT WHEEL SIP	
38	145 9604 000	1	LINK CONNECTING 3/8	[18]
39	1464432000	1	CARBON BRUSH 4 PCS SET	
K1	1464399000	1	HARDWARE DRIVE KIT	[19]

Part Notes:

- [1] - SCREW M8X12
- [2] - NUT SELFLOCKING M18
- [3] - WASHER
- [4] - SCREW HEX HD M5X16
- [5] - WASHER SPLIT 8
- [6] - NUT RING SELFLOCKING
- [7] - SCREW HEX HD M8X25
- [8] - WASHER FLAT 8X17
- [9] - WASHER FLAT 6X24
- [10] - WASHER SPLIT 6
- [11] - WASHER FLAT 6X18
- [12] - WASHER FLAT 4X12
- [13] - SCREW HEX HD M8X30
- [14] - KEY
- [15] - SPACER
- [16] - SCREW HEX HD 6X14
- [17] - TSB IT 2007-025

- [18] - GUARANTEE DATE EXPIRED
TILL S/N 06221124
- [19] - NOT SHOWN (POS.1,2,3,5,6,7,8,10,11,12,13,14,15,16,17,18,20)

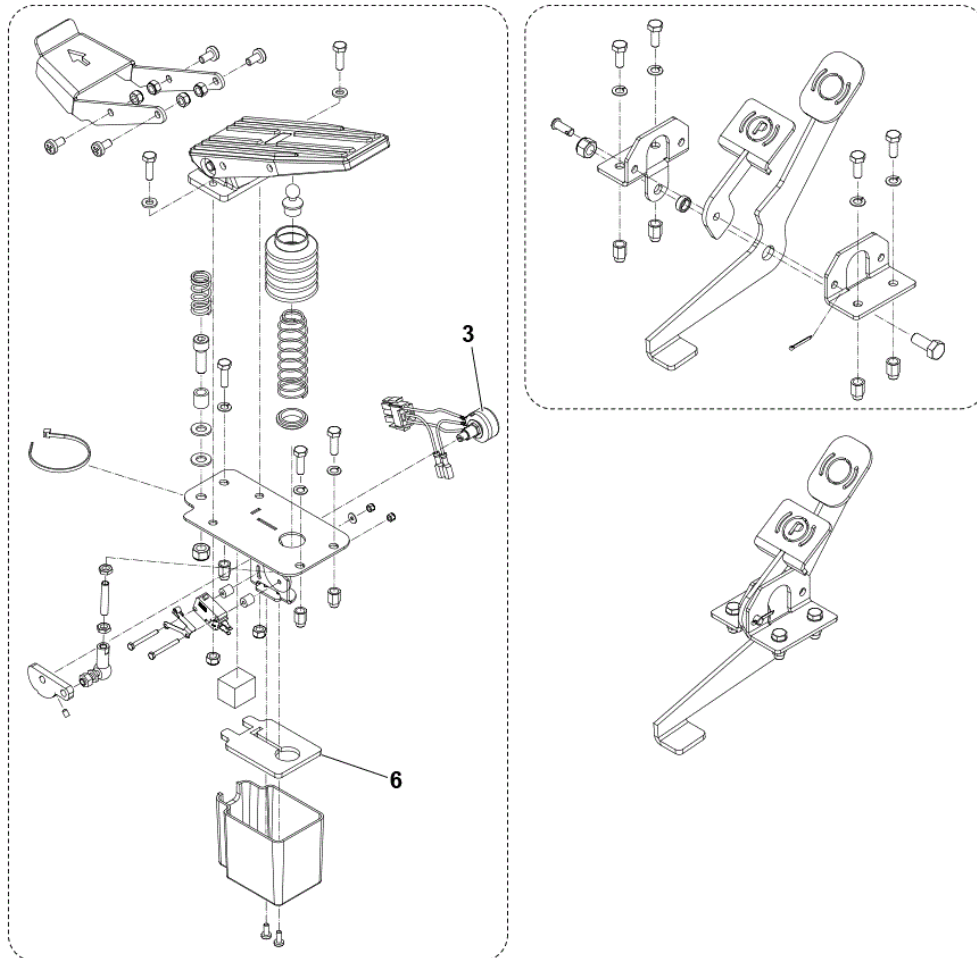

Pedal Assemblies - before serial no. 051807363

2018.01.16

SR 1000 S B

2018.01.16

Pos.	Product no	QTY	Description	Notes
3	146 2480 000	1	HARNESS DRIVE PEDAL	
6	146 2315 000	1	GASKET. PEDAL	

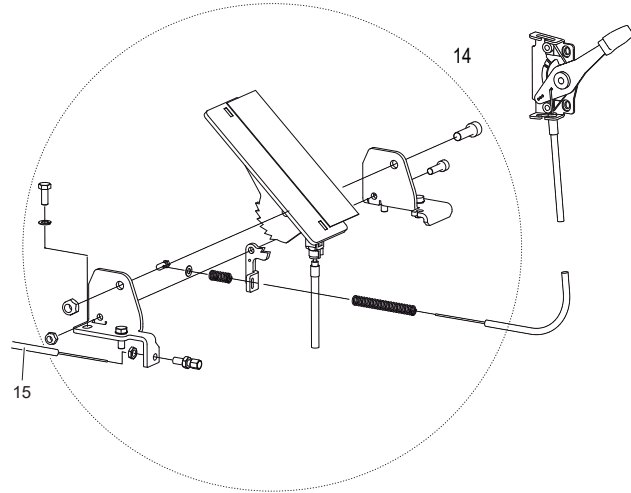
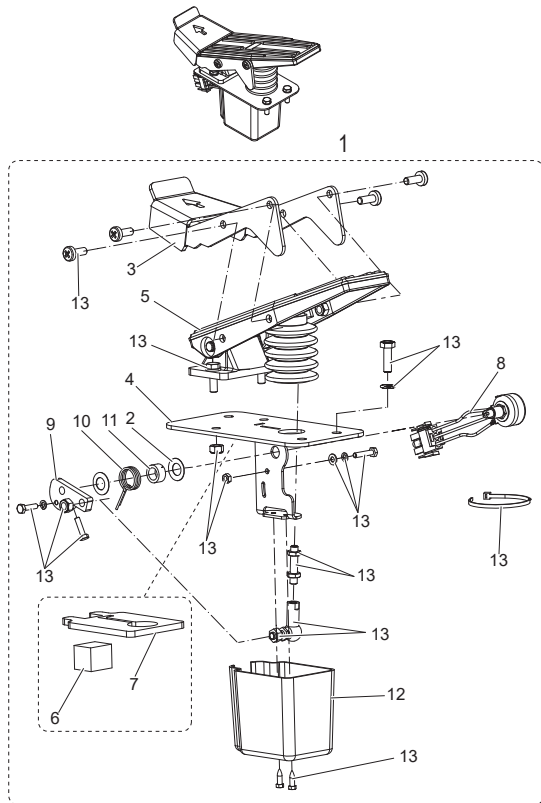

Pos.	Product no	QTY	Description	Notes
1	146 2952 000	1	PEDAL SPEED CONTROL KIT	[1]
2	145 1147 000	2	BELLEVILLE WASHER 10.2X18.8X0.35 DIN2093	
3	146 2929 000	1	BRACKET PEDAL MET.BLACK	
4	146 2930 000	1	SUPPORT SPEED CONTROL PEDAL MET. BLACK	
3+5	1467887000	1	PEDAL SPEED CONTROL REPAIR KIT	
5	1467758000	1	PEDAL SPEED CONTROL SIP	
6	146 2062 000	1	GASKET ADHESIVE 20X20 L. 24MM	
7	146 2315 000	1	GASKET. PEDAL	
8	146 2480 000	1	HARNESS DRIVE PEDAL	
9	146 2882 000	1	LEVER POTENTIOMETER GALV.	
10	1467038000	1	SPRING TORSION WIRE D.1.5 D.I.16.5 SIP	
11	146 2884 000	1	SPACER D10.3X15 H.7.5 PLASTIC	
12	145 4086 000	1	COVER PEDAL PLASTIC	
13	909 6834 000	1	HARDWARE.PEDAL FIXING KIT	
14	1464401000	1	PEDAL BRAKE KIT	[2]
15	1467680000	1	CABLE BRAKE SIP	

Part Notes:

- [1] - starting from S/N 051807363
 [2] - starting from S/N 062211241

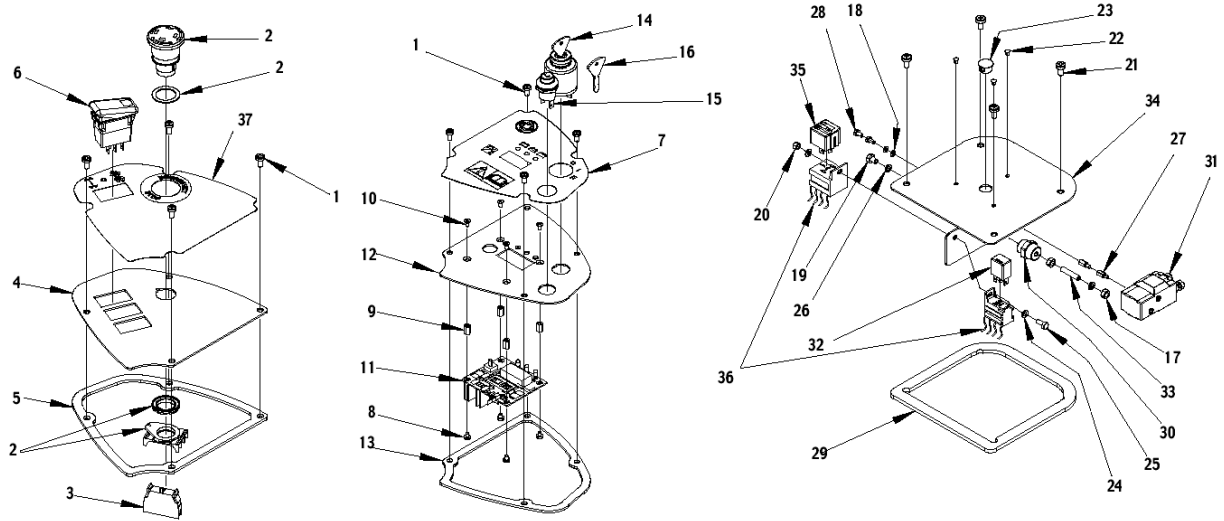

Pos.	Product no	QTY	Description	Notes
1		8	SCREW M5X10	[1]
2	1466683000	1	SWITCH EMERGENCY KIT	
3	146 1728 000	1	CONTACT BLOCK NC RED	
4	146 1930 000	1	CONTROL PANEL LT GALV.	
5	146 1932 000	1	GASKET CONTROL PANEL LT	
6	146 1935 000	1	SWITCH	
7	146 2370 000	1	DECAL CONTROL PANEL RT	
8		4	SCREW M4X5	[2]
9		4	SPACER	[3]
10		4	SCREW M4X8	[4]
11	1466161000	1	CONTROLLER MAIN MACHINE KIT	[5]
12	146 1931 000	1	CONTROL PANEL RT GALV.	
13	146 1933 000	1	GASKET CONTROL PANEL RT	
14	33020442	1	SWITCH IGNITION STARTER W/SPARE KEY KIT	
15	145 9678 000	1	SWITCH PUSH BUTTON F HORN	
16	1467014000	1	KEY F STARTER SWITCH 2 PCS SET	
17		2	NUT M6	[6]
18		2	WASHER D.4	[7]
19		1	SCREW M6X8	[8]
20		1	NUT SELFLOCKING M5	[9]
21		4	SCREW M6X12	[10]
22		3	CAP	[11]
23	145 8008 000	1	PLUG DOME O.D. 18.2 PLASTIC BLACK	
24		2	WASHER FLAT 5X10	[12]
25		1	SCREW M5X12	[13]
26		2	WASHER D.6	[14]
27		2	SPACER	[3]
28		2	SCREW M4X8	[4]
29	146 0697 000	1	GASKET ADHESIVE F CONTR. PANEL	
30	146 0708 000	1	INSULATOR M6 WHITE	
31	146 0719 000	1	SWITCH ELECTROMAGNETIC 24V	
32	146 1646 000	1	RELAY 24V	
33	146 1678 000	1	SCREW GRUB M6X30 CUP POINT ISO4029	
34	146 1936 000	1	CONTROL PANEL MET. GREY	
35	145 3712 000	1	RELAY 24V	
36	146 1903 000	1	HARNES REAR CONTROL PAN.	
37	146 2371 000	1	DECAL CONTROL PANEL LT	
38	146 1902 000	1	HARNES CONTROL PANEL	[15]
K1	1464402000	1	HARDWARE CONTR. PANEL KIT	[16]

Part Notes:

- [1] - SCREW M5X10
- [2] - SCREW M4X5
- [3] - SPACER
- [4] - SCREW M4X8
- [5] - INST. INSTR. 1465914000
- [6] - NUT M6
- [7] - WASHER D.4
- [8] - SCREW M6X8
- [9] - NUT SELFLOCKING M5
- [10] - SCREW M6X12
- [11] - CAP
- [12] - WASHER FLAT 5X10
- [13] - SCREW M5X12
- [14] - WASHER D.6
- [15] - NOT SHOWN
- [16] - NOT SHOWN (POS.1-8-9-10-17-18-19-20-21-22-24-25-26-27-28)

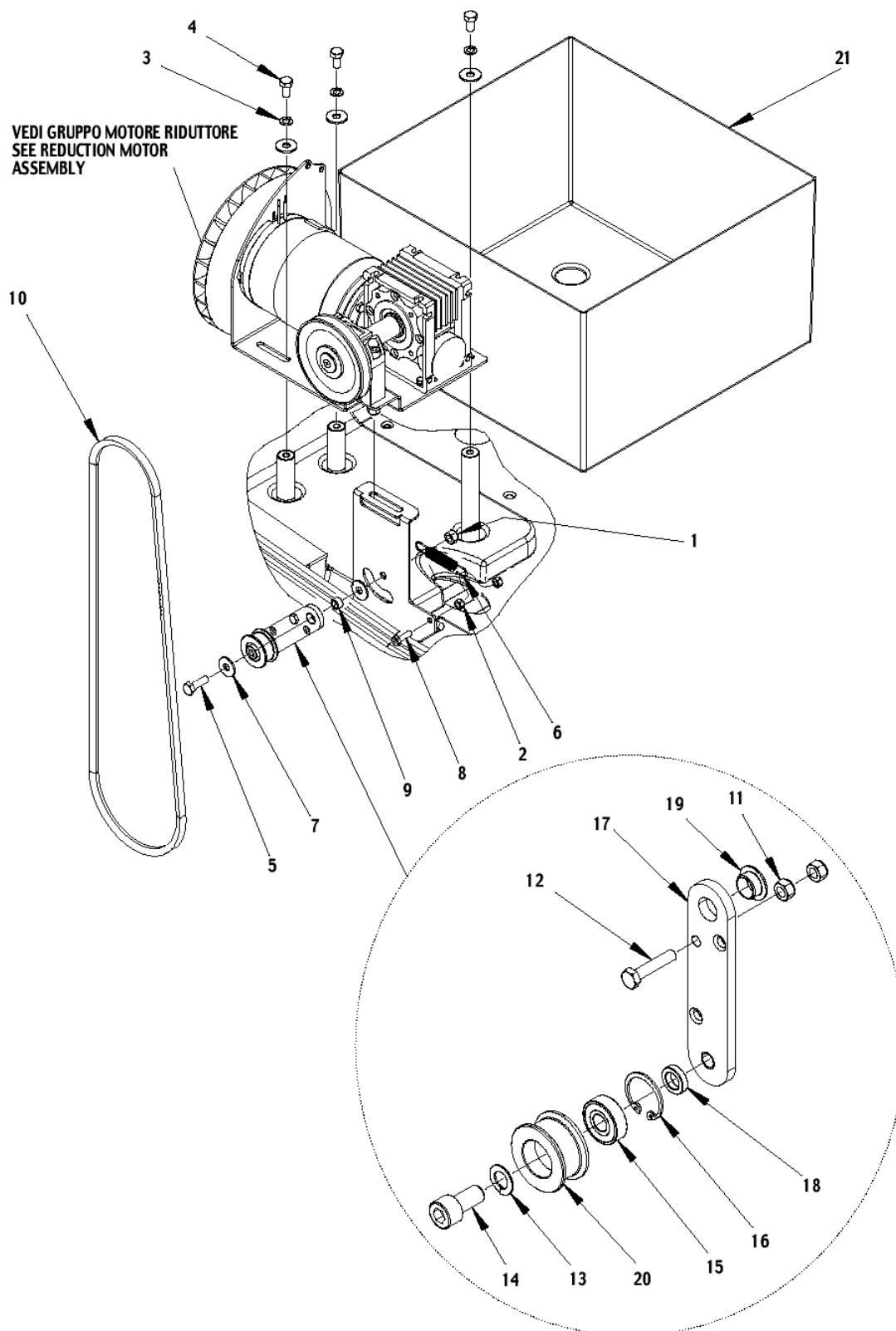

Pos.	Product no	QTY	Description	Notes
1		1	NUT SELFLOCKING M8	[1]
2		2	SCREW M6X30	[2]
3		3	WASHER SPLIT 8	[3]
4		3	SCREW M8X16	[4]
5		1	SCREW M8X25	[5]
6	146 3135 000	1	SPRING EXTENSION	
7		5	WASHER FLAT 8X24	[6]
8		1	SCREW M6X20	[7]
9		1	SPACER	[8]
10	146 3136 000	1	BELT V COGGED SPZX 1212	
11		2	NUT SELFLOCKING M6	
12		1	SCREW M6X30	[9]
13		1	WASHER SPLIT 10	[10]
14		1	SCREW M10X20	[11]
15		1	BALL BEARING	[12]
16		1	RETAINING RING	[13]
17		1	BELT TENSIONER ARM	[14]
18		1	SPACER	[8]
19		1	BEARING WITH FLANGE	[15]
20		1	BELT TENSIONER ROLLER	[16]
21	146 1684 000	1	CONTAINER BATTERY	[17]
K1	1464403000	1	HARDWARE TRANSMISSION KIT	[18]

Part Notes:

- [1] - NUT SELFLOCKING M8
- [2] - NUT SELFLOCKING M6
- [3] - WASHER SPLIT 8
- [4] - SCREW M8X16
- [5] - SCREW M8X25
- [6] - WASHER FLAT 8X24
- [7] - SCREW M6X20
- [8] - SPACER
- [9] - SCREW M6X30
- [10] - WASHER SPLIT 10
- [11] - SCREW M10X20
- [12] - BALL BEARING
- [13] - RETAINING RING
- [14] - BELT TENSIONER ARM
- [15] - BEARING WITH FLANGE
- [16] - BELT TENSIONER ROLLER
- [17] - 2020 ACCESSORY PRUNING
- [18] - NOT SHOWN (POS.1-2-3-4-5-7-8-9-12-13-14-15-16-17-18-19-20)

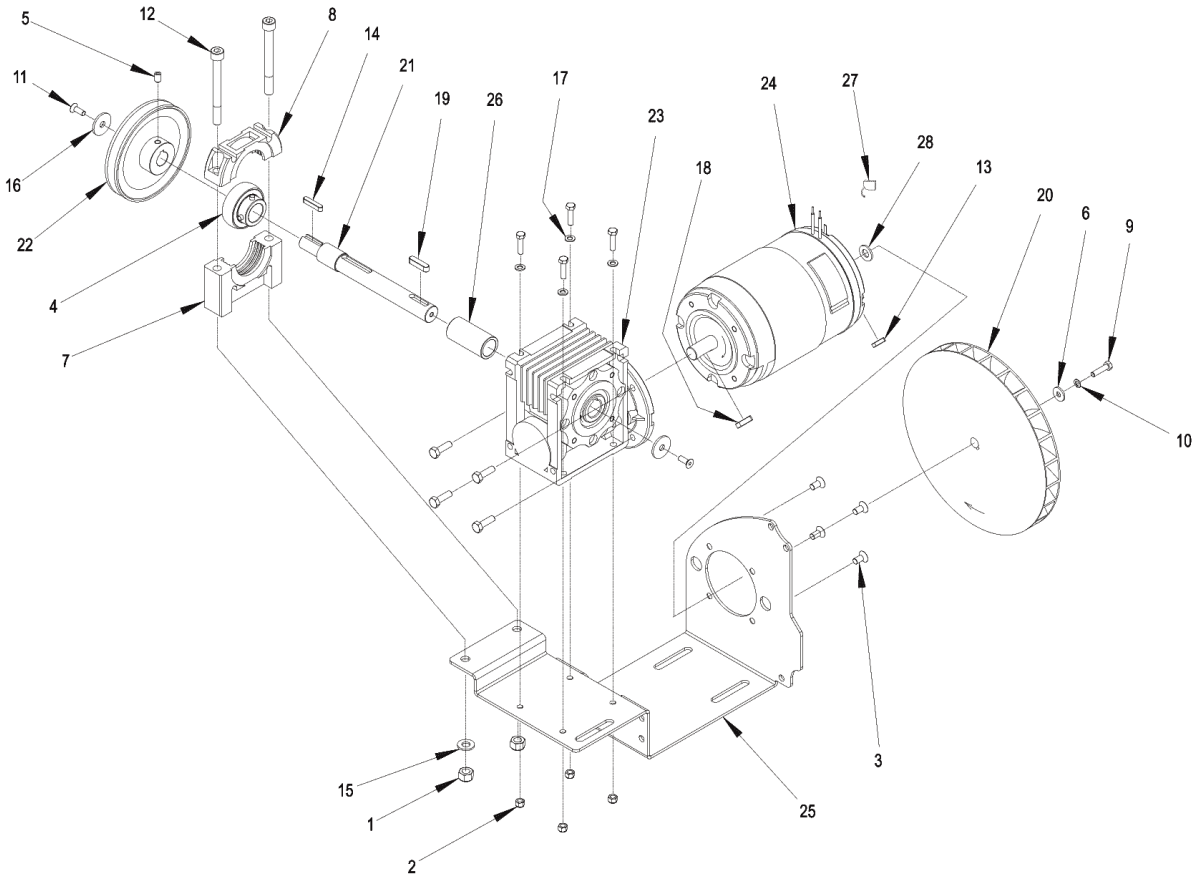

Pos.	Product no	QTY	Description	Notes
1		1	NUT SELFLOCKING M8	[1]
2		2	NUT SELFLOCKING M6	[2]
3		3	WASHER SPLIT 8	[3]
4	145 1123 000	1	BEARING BALL YAT204	
5		1	SCREW M8X25	[4]
6		1	WASHER FLAT 5X15	[5]
7	145 1976 000	1	SUPPORT BEARING LOWER PLAST.	
8	145 1977 000	1	SUPPORT BEARING UPPER PLAST.	
9		1	SPACER	[6]
10		5	WASHER FLAT 8X24	[7]
11		1	SCREW M6X20	[8]
12		1	SCREW M6X30	[9]
13	146 1489 000	1	KEY 4X4X15 UNI6604A	
14	1466146000	1	KEY 5X5X25 UNI6604A SIP	
15		1	BALL BEARING	[10]
16		1	RETAINING RING	[11]
17		1	BELT TENSIONER ARM	[12]
18	1466147000	1	KEY 5X5X20 UNI6604A SIP	
19	145 9899 000	1	KEY 6X6X25 UNI6604A	
20	146 0537 000	1	FAN RADIAL D.200 HOLE D.11 ALU	
21	146 0540 000	1	SHAFT TRANSMISSION	
22	146 1921 000	1	PULLEY ALU SPZ DP.100	
23	1463249000	1	REDUCTION GEAR COMPLETE 5 1	
24	1467528000	1	MOTOR ELECTRIC 600W 24V SIP	
25	146 1924 000	1	PLATE REDUCTION GEARBOX GALV.	
26	146 1925 000	1	SPACER D.18X24 H.48.5 GALV.	
27	L08603949	1	CARBON BRUSH 4 PCS SET	
28	146 2814 000	1	WASHER F ELECTRIC MOTOR	
K1	1464404000	1	HARDWARE REDUCT.MOTOR KIT	[13]

Part Notes:

- [1] - NUT SELFLOCKING M8
- [2] - NUT SELFLOCKING M6
- [3] - WASHER SPLIT 8
- [4] - SCREW M8X25
- [5] - WASHER FLAT 5X15
- [6] - SPACER
- [7] - WASHER FLAT 8X24
- [8] - SCREW M6X20
- [9] - SCREW M6X30
- [10] - BALL BEARING
- [11] - RETAINING RING
- [12] - BELT TENSIONER ARM
- [13] - NOT SHOWN (POS.1-2-3-5-6-9-10-11-12-13-14-15-16-17-18-19)

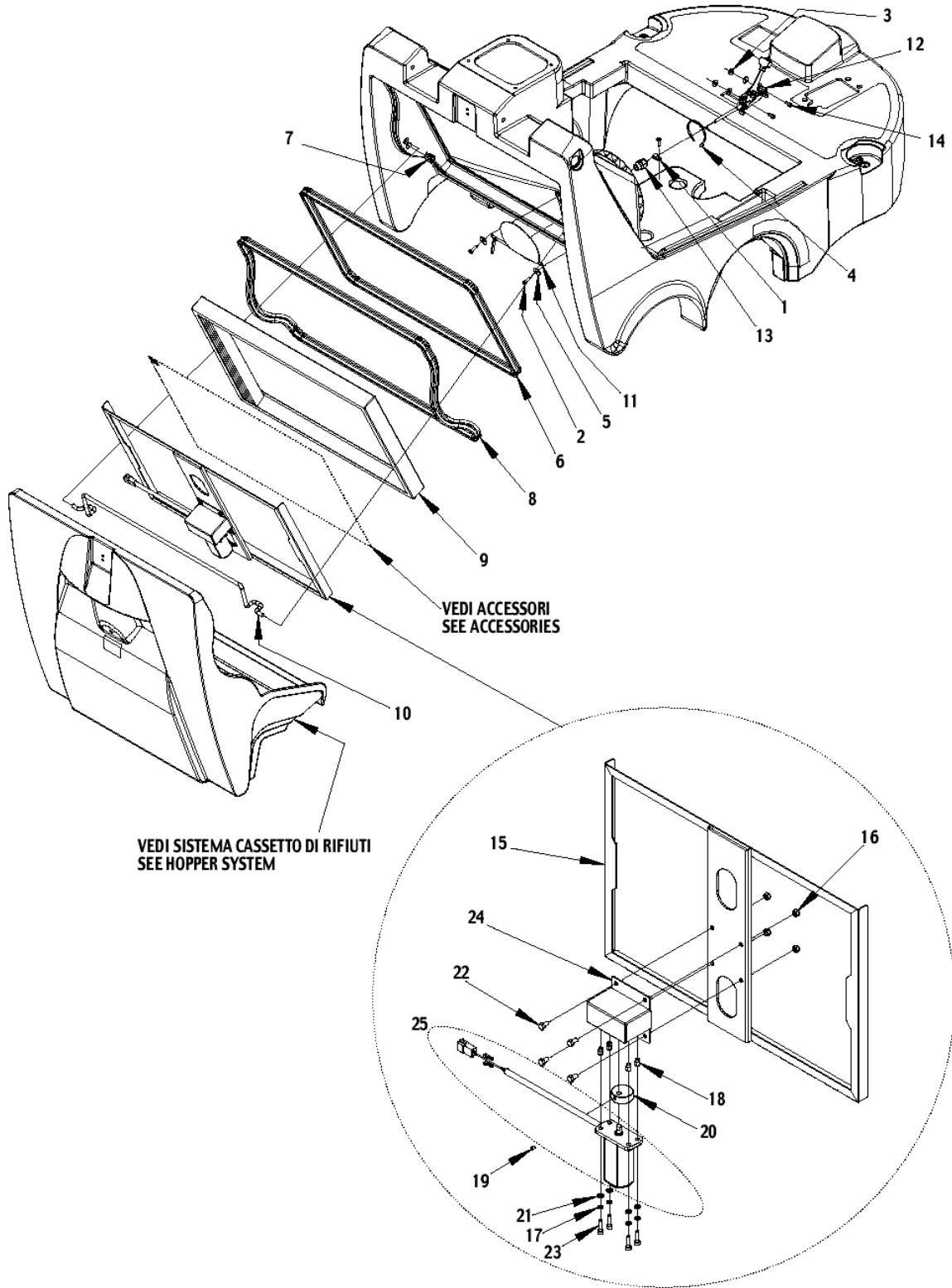

Pos.	Product no	QTY	Description	Notes
1		1	CLAMP GREY	[1]
2		3	SCREW M4.6X19.2	[2]
3		4	WASHER FLAT 5X15	[3]
4		1	CLAMP	[4]
5		2	WASHER FLAT 5X20	[5]
6	146 0630 000	1	GASKET BULB RUBBER L.1850MM SIP	
7	146 0661 000	1	GROMMET	
8	146 0741 000	1	GASKET BULB RUBBER L.2030MM SIP	
9	146 1888 000	1	FILTER PAPER	
9	146 1989 000	1	FILTER POLYESTER ANTIST.	[6]
9	146 1988 000	1	FILTER POLYESTER	[6]
10	146 1889 000	1	CLAMP FILTER	
11	146 1890 000	1	VALVE THROTTLE GALV.	
12	146 1891 000	1	LEVER W/CABLE F VACUUM CONTROL	[7]
13	146 1892 000	1	CLAMP CABLE	
14		2	SCREW M5X10	[8]
15	146 1947 000	1	FRAME FOR PANEL FILTER	
16		4	NUT SELFLOCKING M6	[9]
17		4	WASHER SPLIT 5	[10]
18		4	INSERT HEX. 5	[11]
19		1	DOWEL	[12]
20	1466857000	1	CAM F FILTER SHAKER KIT	
21		4	WASHER FLAT M5X10	[13]
22		4	SCREW M6X12	[14]
23		4	SCREW M5X20	[15]
24	1466335000	1	BRACKET FILTER SHAKER SIP	
25	1466314000	1	MOTOR FILTER SHAKER 12W 24V KIT	
26	146 1893 000	1	PRE-FILTER	[16]
K1	1464405000	1	HARDWARE DUST CONTROL KIT	[17]

Part Notes:

- [1] - CLAMP GREY
- [2] - SCREW M4.6X19.2
- [3] - WASHER FLAT 5X15
- [4] - CLAMP
- [5] - WASHER FLAT 5X20
- [6] - OPTIONAL
- [7] - GUARANTEE DATE EXPIRED
- [8] - SCREW M5X10
- [9] - NUT SELFLOCKING M6
- [10] - WASHER SPLIT 5
- [11] - INSERT HEX. 5
- [12] - DOWEL
- [13] - WASHER FLAT M5X10
- [14] - SCREW M6X12
- [15] - SCREW M5X20
- [16] - NOT SHOWN - OPTIONAL
- [17] - NOT SHOWN (POS.1-2-3-4-5-14-16-17-18-19-21-22-23)

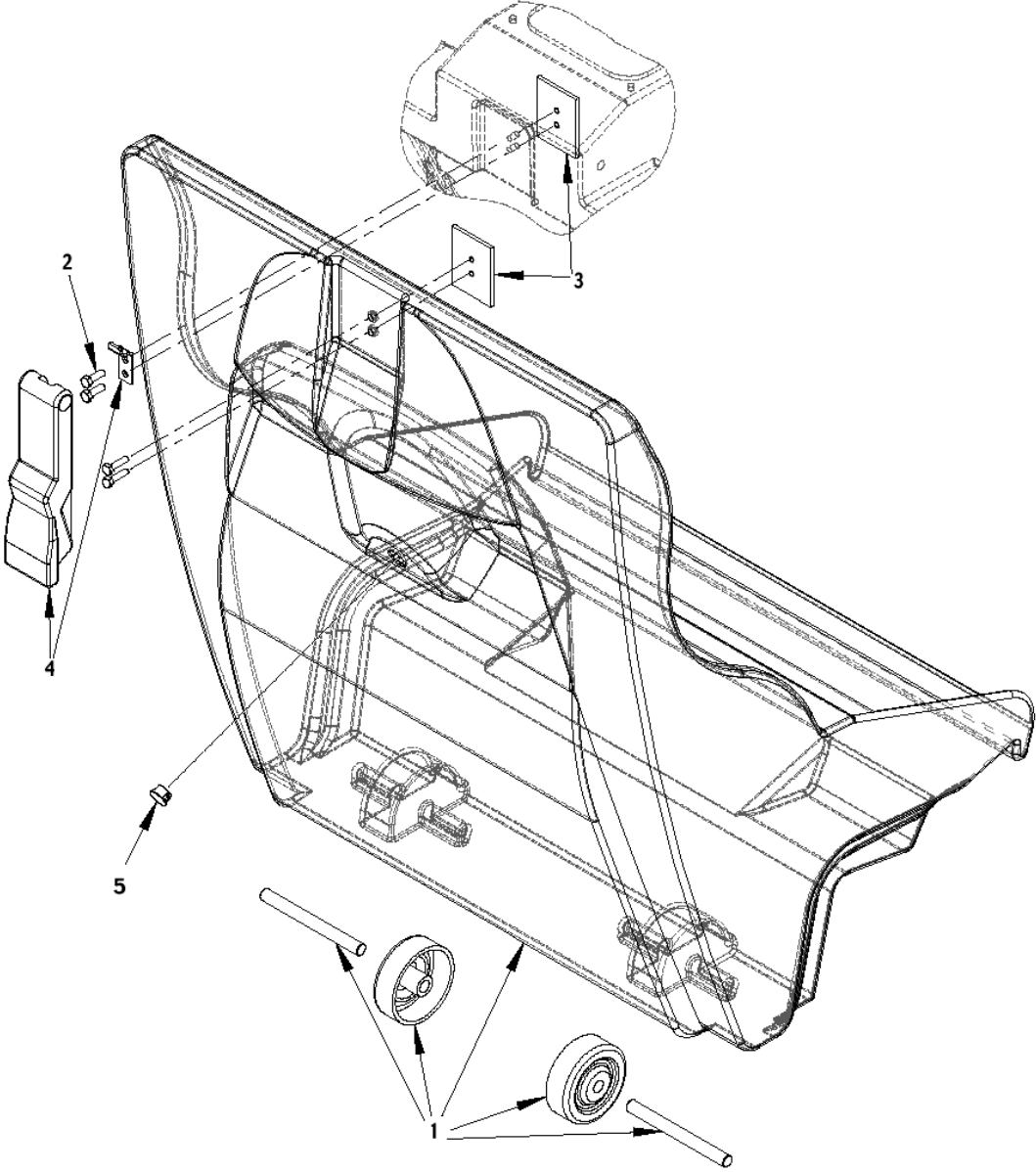

Pos.	Product no	QTY	Description	Notes
1	1466159000	1	CONTAINER WASTE GREY ROTOMOULDED KIT	
2	33003963	4	SCREW M5X20 HEX HD F/THD ISO4017	
3	146 0562 000	2	PLATE LATCH FIXING GALV.	
7	146 0520 000	1	LATCH RUBBER	
5	145 4259 000	1	PLUG DOME PLASTIC BLACK D.11.9	

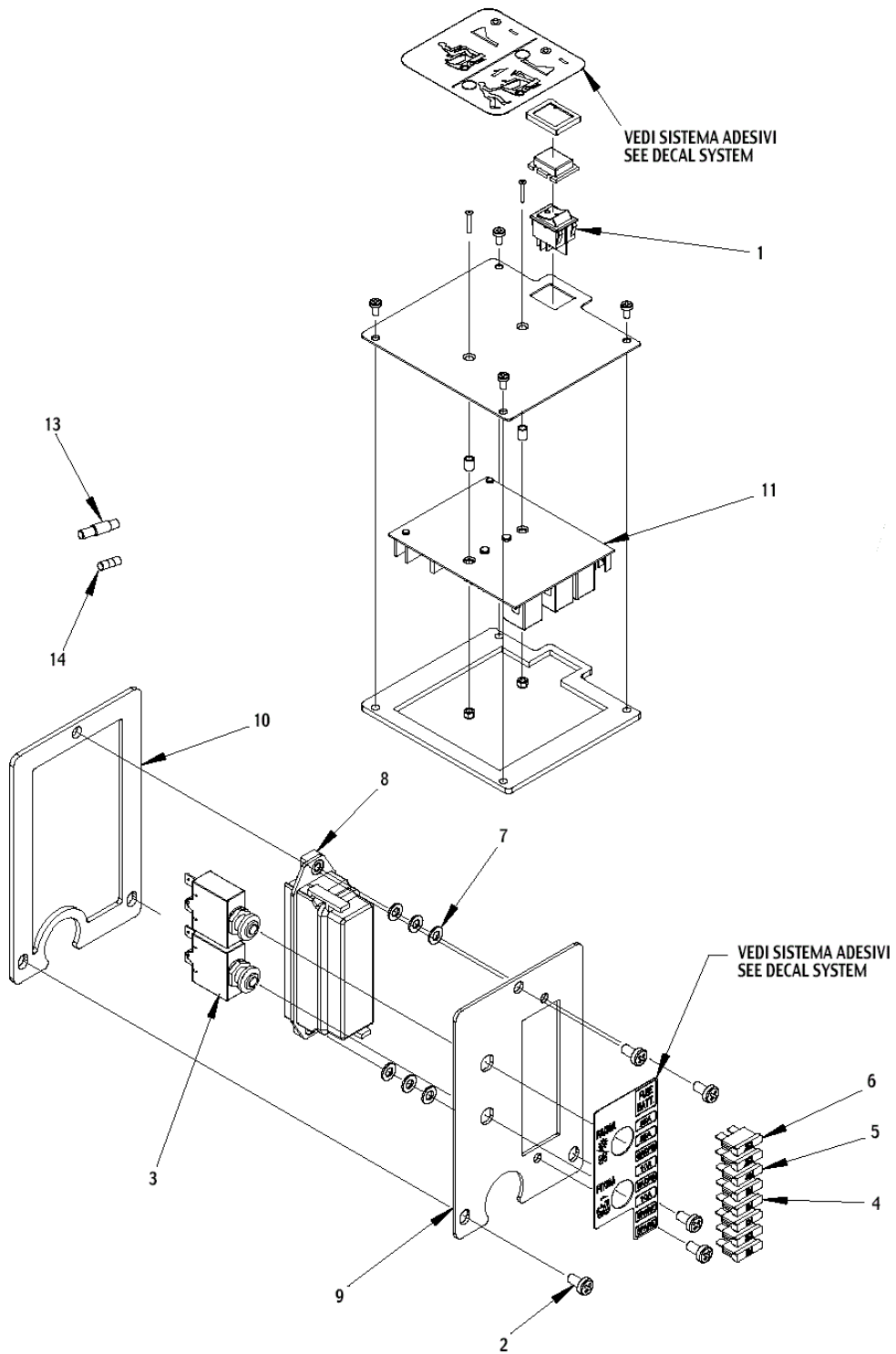

Pos.	Product no	QTY	Description	Notes
1	909 5668 000	1	SWITCH ROCKER ORANGE 2 POS. -1 MOM.	
2	L08603041	4	SCREW M5X10 PAN HD PHIL ISO7045 SCOTCH-	
3	909 5706 000	2	CIRCUIT BREAKER 30A	
4	1467034000	3	FUSE BLADE 10A SIP	
5	145 0227 000	1	FUSE BLADE 40A	
6	145 8514 000	2	FUSE BLADE 25A	
7	33023195	1	WASHER PLAIN M5 ISO7089 10 PCS SET	
8	146 1170 000	1	HOLDER FUSE 8 WAYS	
9	146 1952 000	1	PANEL ELECTR.COMPONENTS MET. BLACK	
10	146 1953 000	1	GASKET	
11	1466174000	1	CONTROLLER DRIVE WHEEL SIP	
13	146 2243 000	1	FUSEHOLDER IN LINE 5X20-6.3X32 FUSE	
15	146 1986 000	1	CONNECTOR 120A RED	
16	1463241000	1	HARNESS SEAT MICRO KIT	[1]

Part Notes:

[1] - GUARANTEE DATE EXPIRED

NOT SHOWN - INSTAL.INSTR. 1463243000

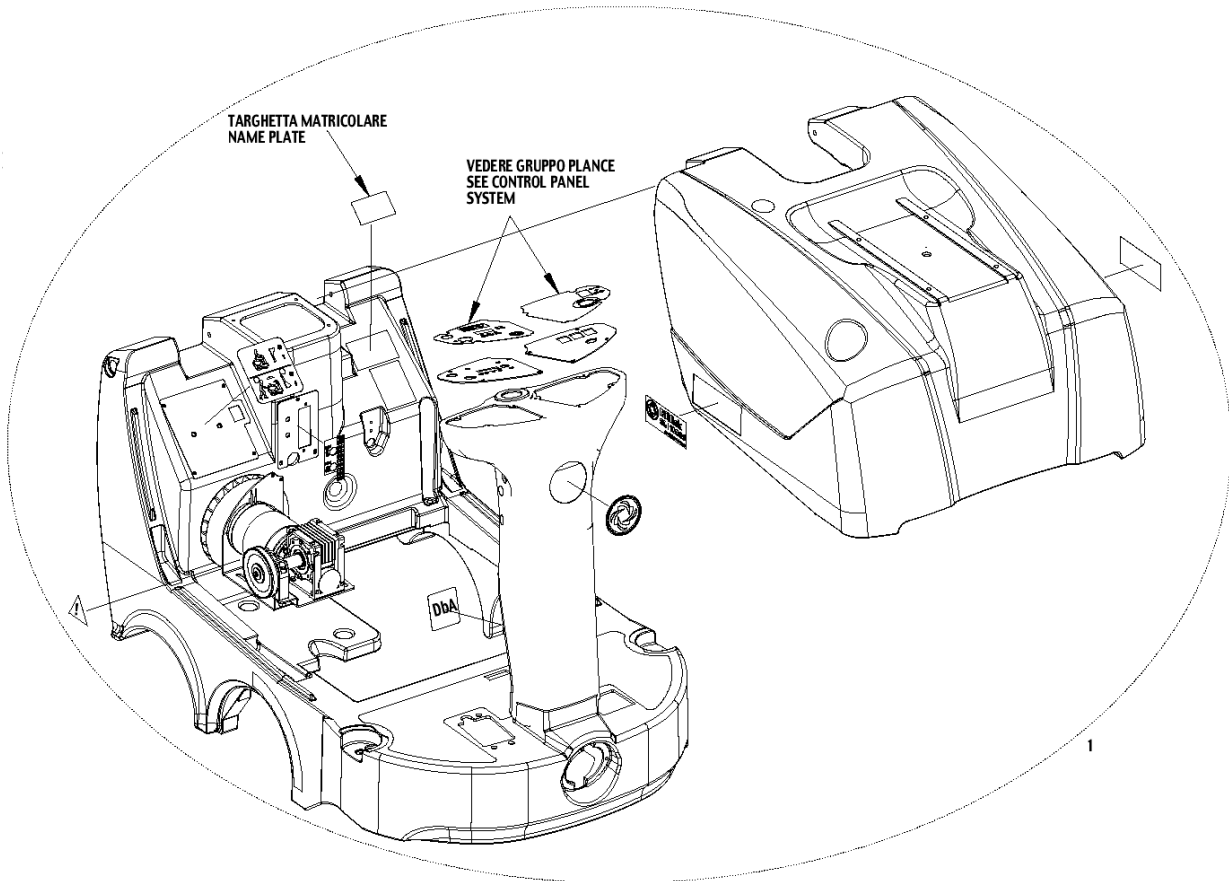

Pos.	Product no	QTY	Description	Notes
1	1463742000	1	DECALS SR 1000S B KIT	

KIT CARICA BATTERIA / BATTERY CHARGER KIT

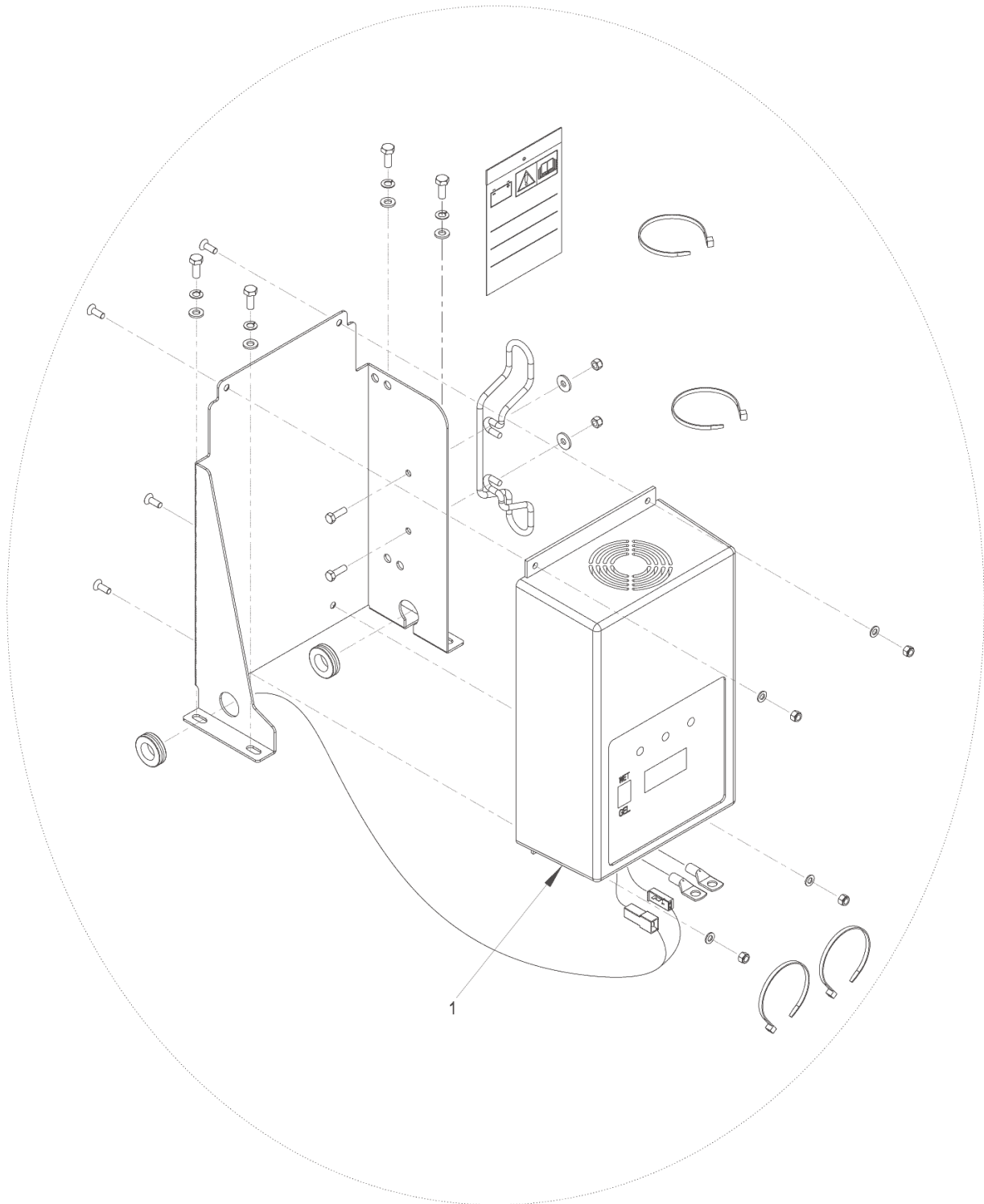

Pos.	Product no	QTY	Description	Notes
0A	146 2052 000	1	CHARGER BATT. ON BOARD 24V 25A 230V KIT	[1]
1A	146 2131 000	1	CHARGER BATT. ON BOARD 24V 25A 230V CPL	[2]
2A	146 2142 000	1	FAN COOLING	[3]
3A	145 1726 000	1	FUSE 10A	[4]
4A	1466172000	1	CONTROLLER DISPLAY SIP	[5]
5A	146 2139 000	1	CARD ELECTRONIC BATTERY CHARGER	[4]
6A	146 0801 000	1	SWITCH WET/GEL	[3]
A7	146 2144 000	1	CORD POWER SUPPLY F BATTERY CHARGER	[3]
0B	1464527000	1	CHARGER BATT. ON BOARD 24V 13A 230V KIT	[6]
1B	1466315000	1	CHARGER BATT. ON BOARD 24V 13A 230V SIP	[7]
2B	1465917000	1	HARDWARE BATTERY CHARGER KIT	[8]
3B	9100000787	1	CABLE EXTENSION EU PLUG L.2000MM SIP	[8]
3B	1467891000	1	CABLE EXTENSION SWISS PLUG L.2000MM SIP	

Part Notes:

- [1] - NOT SHOWN - OPT. BEFORE SN 3810144200009 - FOR 146 2131 000 - INST. INSTR. 146 2055 000
- [2] - BEFORE SN 3810144200009
- [3] - ALTERNATIVE USE 146 2132 000 COMPL.
NOT SHOWN - BEFORE SN 3810144200009 - FOR 146 2131 000
- [4] - NOT SHOWN - BEFORE SN 3810144200009 - FOR 146 2131 000
- [5] - ALTERNATIVE USE 146 2132 000
NOT SHOWN - BEFORE SN 3810144200009 - FOR 146 2131 000
- [6] - NOT SHOWN - STARTING FROM BEFORE SN 3810144200009 - FOR 1466315000 - INST. INSTR. 1464529000
- [7] - STARTING FROM BEFORE SN 3810144200009
- [8] - NOT SHOWN - STARTING FROM BEFORE SN 3810144200009 - FOR 1466315000

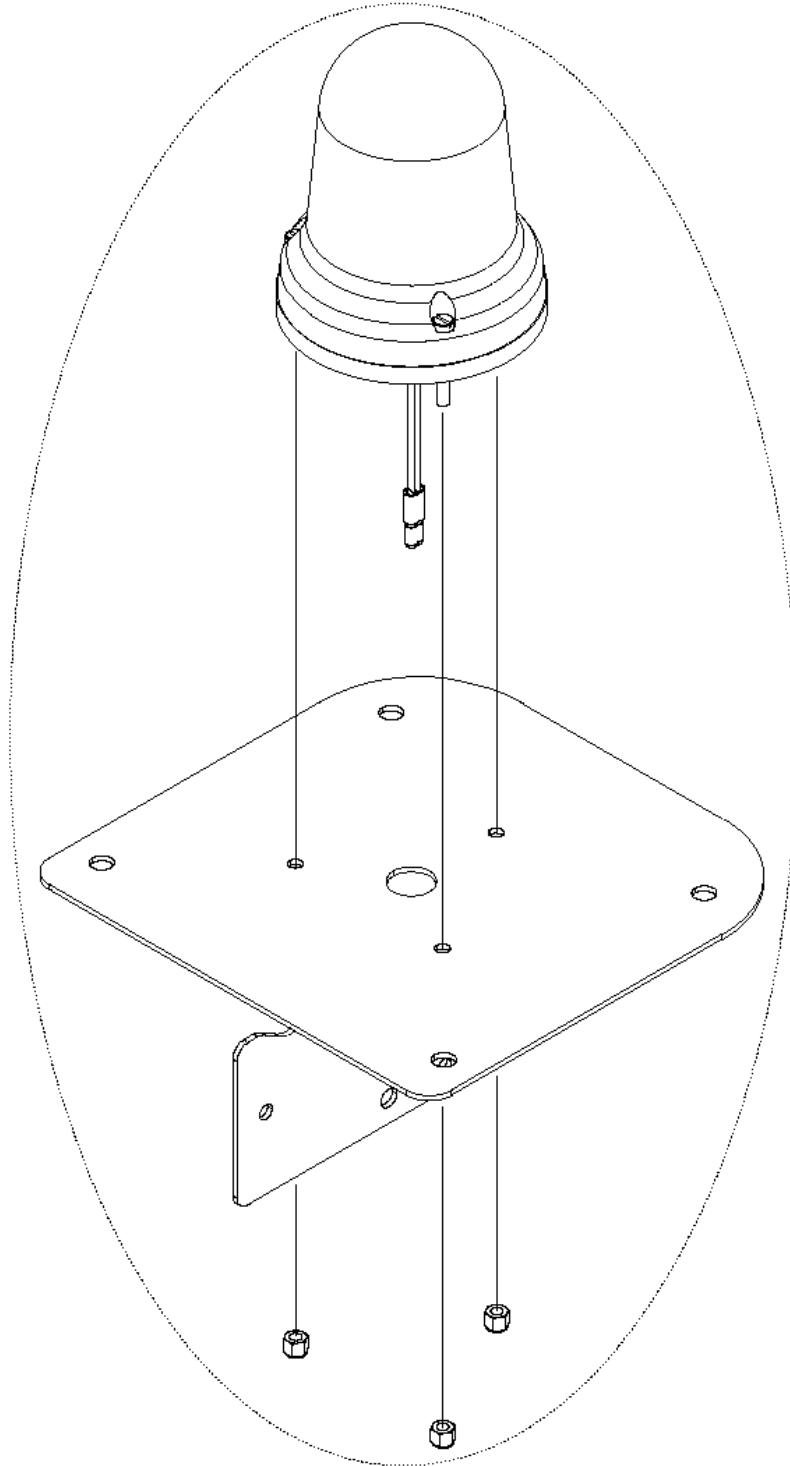

Accessories 2

SR 1000 S B

2017.11.02

2016.03.03

Pos.	Product no	QTY	Description	Notes
0	146 2659 000	1	BEACON FLASHING KIT	

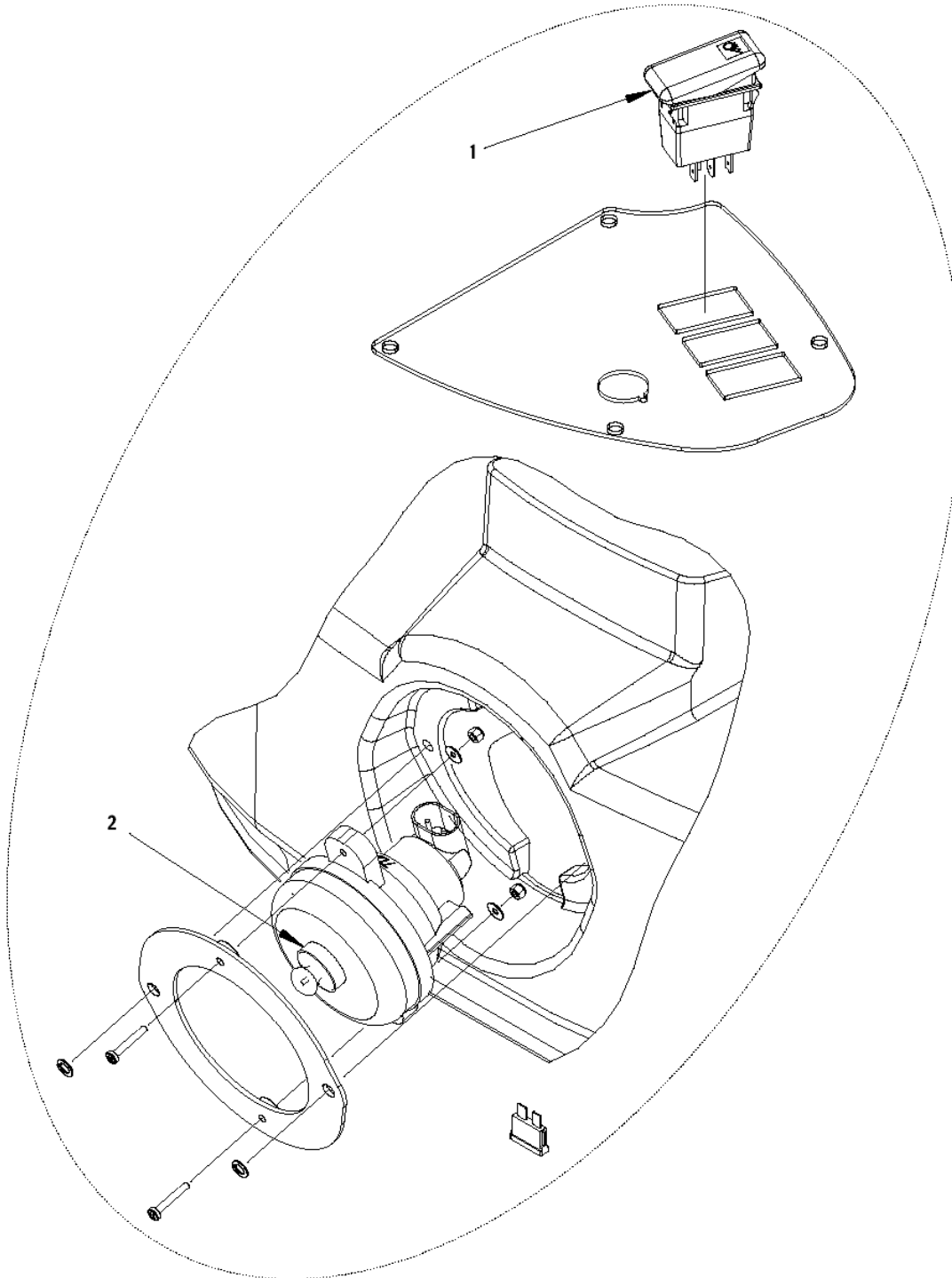

Pos.	Product no	QTY	Description	Notes
	146 2663 000	1	LIGHT WORKING KIT	
1	146 1974 000	1	SWITCH	
2	145 5518 000	1	LAMP 24V 21W	[1]

Part Notes:

[1] - BUY LOCALLY

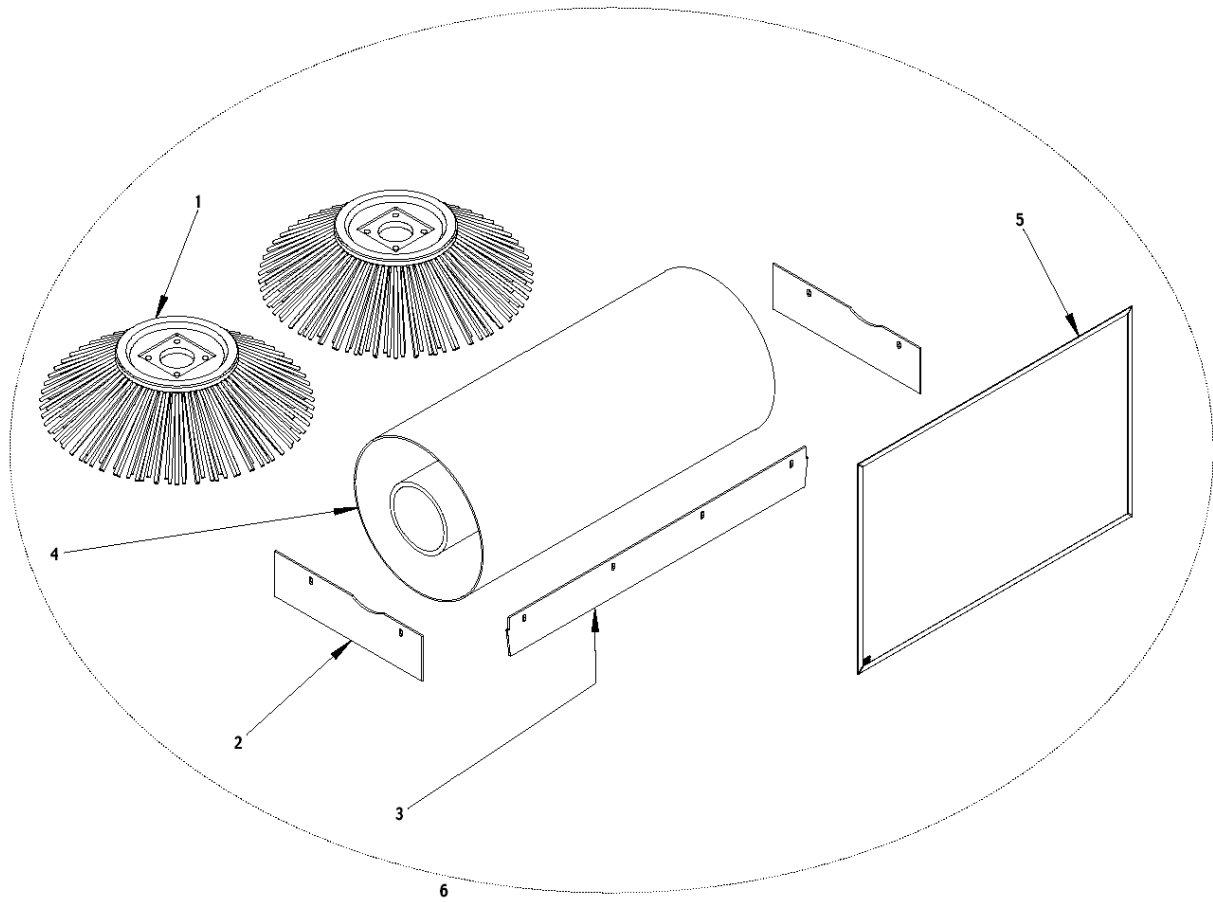

Pos.	Product no	QTY	Description	Notes
1	145 4976 000	2	BROOM SIDE 180X400 NATURAL	
2	146 0587 000	2	SKIRT SIDE NON MARKING	
3	146 0743 000	1	SKIRT REAR NON MARKING	
4	146 0753 000	1	BROOM MAIN 245X600 CHEVRON 6R NATURAL	
5	146 1893 000	1	PRE-FILTER	
6	146 2102 000	1	CARPET KIT	

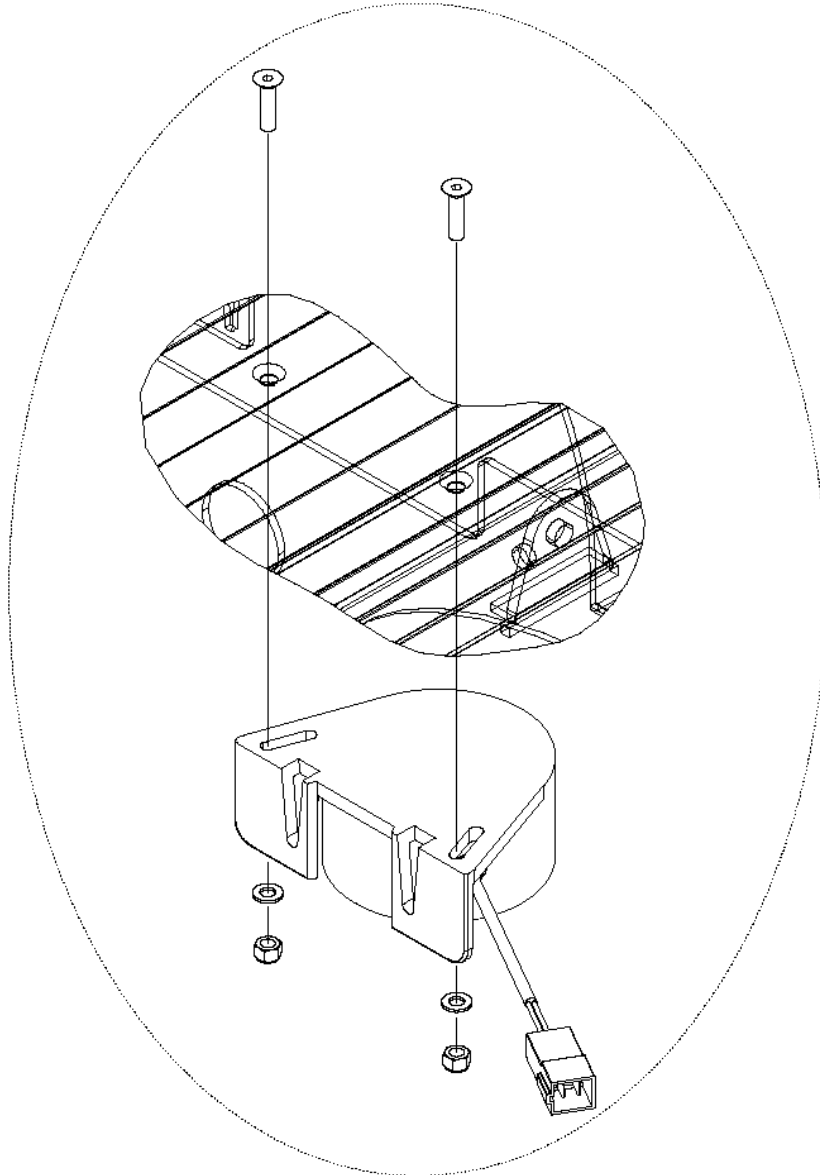

Accessories 5

SR 1000 S B

2017.11.02

2016.03.03

Pos.	Product no	QTY	Description	Notes
0	146 2661 000	1	ALARM BACK UP KIT	

Resource notes:

POSITION 44: 146 2134 000 till machine serial number 051807363 - VALID TILL 18.05.2005 see TSB IT 2005-009TSB IT 2005-009. New accelerator pedal

Recommended spare parts 1

SR 1000 S B

2018.01.16

2018.01.16

Pos.	Product no	QTY	Description	Notes
1	146 1888 000	1	FILTER PAPER	
2	146 0738 000	1	SKIRT REAR	
3	146 0756 000	1	SKIRT FRONT SOFT	
4	146 0555 000	2	SKIRT SIDE	
5	146 0748 000	1	BROOM MAIN 265X600 CHEVRON 6R PPL 0.7	
6	145 1899 000	2	BROOM SIDE 180X400 PPL 0.7	
7	145 8514 000	2	FUSE BLADE 25A	
8	145 0227 000	1	FUSE BLADE 40A	
9	1467034000	4	FUSE BLADE 10A SIP	
10	145 9184 000	1	SPRING EXTENSION D.E.12 WIRE D.1.5	
11	146 3136 000	1	BELT V COGGED SPZX 1212	
12	146 0519 000	2	HUB SIDE BROOM	
13	1464432000	1	CARBON BRUSH 4 PCS SET	
14	1464433000	4	CARBON BRUSH 4 PCS SET	
15	146 1899 000	2	WHEEL D.250X50 BLACK/GREY	
16	1463184000	1	WHEEL FRONT KIT	
17	146 0945 000	2	WHEEL D.75X28 BLACK/GREY	
18	145 4536 000	2	SPRING PIN M6X12 GALV	
19	145 1975 000	1	CABLE SKIRT RAIS.DEVICE	
20	145 1935 000	1	SPRING COMPRESSION D.E.9 WIRE D.1	
21	1466518000	1	BRAKE FRONT WHEEL SIP	
25	145 0222 000	1	CHAIN ROLLER 3/8-35 P.+HL+CL	
26	146 2166 000	1	REDUCTION GEARMOTOR 4000W 24V KIT	
27	1464152000	2	REDUCTION GEARMOTOR 60W 24V	
28	145 0274 000	2	SPRING EXTENSION D.E.12 WIRE D.1.5	
29	146 1895 000	2	CABLE SIDE BROOM L.1217MM	[1]
30	146 0719 000	1	SWITCH ELECTROMAGNETIC 24V	
31	146 1646 000	1	RELAY 24V	
32	145 3712 000	1	RELAY 24V	
33	1466161000	1	CONTROLLER MAIN MACHINE KIT	
34	146 0565 000	1	SWITCH PUSH BUTTON	
35	1467636000	1	BEARING TAPER ROLLER 32006 SIP	[2]
36	145 0225 000	1	BEARING BALL 6006 2RS1	
37	146 1928 000	1	GASKET	[1]
38	145 0221 000	1	SPROCKET T17 3/8-7/32	
39	146 0741 000	1	GASKET BULB RUBBER L.2030MM SIP	
40	146 0630 000	1	GASKET BULB RUBBER L.1850MM SIP	
41	146 1891 000	1	LEVER W/CABLE F VACUUM CONTROL	[1]
42	1466314000	1	MOTOR FILTER SHAKER 12W 24V KIT	
43	909 5668 000	1	SWITCH ROCKER ORANGE 2 POS. -1 MOM.	
48	1467014000	1	KEY F STARTER SWITCH 2 PCS SET	
49	1466174000	1	CONTROLLER DRIVE WHEEL SIP	
50	1466506000	1	MICROSWITCH 15A 250V SIP	
51	909 5706 000	2	CIRCUIT BREAKER 30A	

Part Notes:

- [1] - GUARANTEE DATE EXPIRED
- [2] - Till S/N 06221124

Pos.	Product no	QTY	Description	Notes
52	146 1988 000	1	FILTER POLYESTER	
53	146 1989 000	1	FILTER POLYESTER ANTIST.	
54	146 0749 000	1	BROOM MAIN 265X600 CHEVRON 6R NATURAL	[1]
55	146 0750 000	1	BROOM MAIN 265X600 CHEVRON 6R MIX STEEL	
56	146 0751 000	1	BROOM MAIN 245X600 CHEVRON 6R PPL 0.7	
57	146 0753 000	1	BROOM MAIN 245X600 CHEVRON 6R NATURAL	
58	146 0752 000	1	BROOM MAIN 245X600 CHEVRON 6R NYLON	
59	145 4959 000	2	BROOM SIDE 180X400 MIX STEEL	
60	145 4976 000	2	BROOM SIDE 180X400 NATURAL	
61	146 0678 000	2	BROOM SIDE 180X350 NYLON	
62	146 2659 000	1	BEACON FLASHING KIT	
63	146 2661 000	1	ALARM BACK UP KIT	
64	146 2303 000	1	HARDWARE.VAC.CLEANER KIT SR 1000S	
65	146 2661 000	1	ALARM BACK UP KIT	
66	146 2052 000	1	CHARGER BATT. ON BOARD 24V 25A 230V KIT	
67	146 2102 000	1	CARPET KIT	
68	146 0587 000	2	SKIRT SIDE NON MARKING	
69	146 0743 000	1	SKIRT REAR NON MARKING	
71	146 1893 000	1	PRE-FILTER	

Part Notes:

[1] - PI 2015-001 TTY

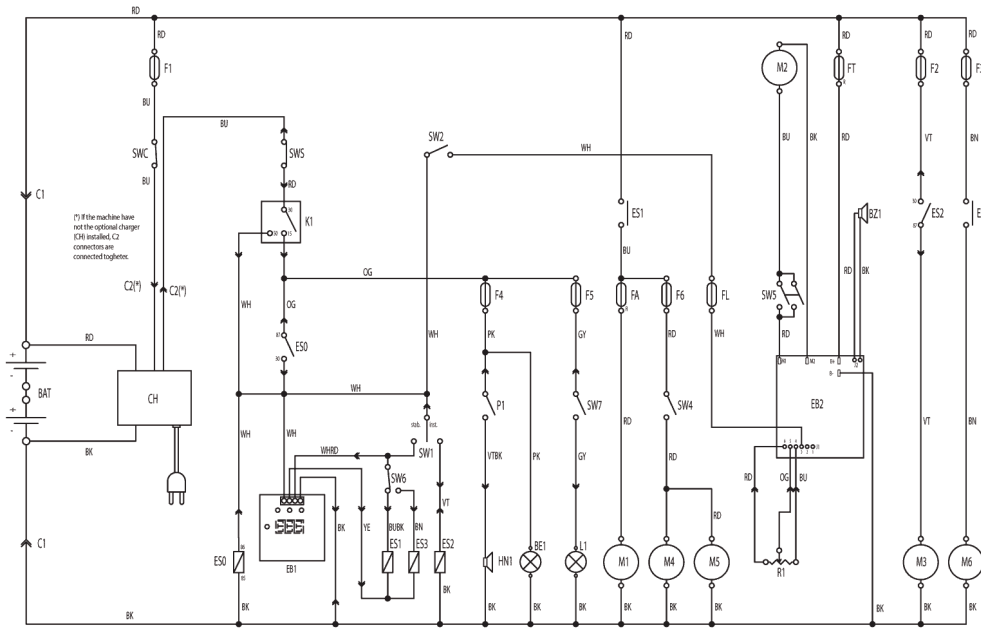

WIRING DIAGRAM
SR1000S B
146 2006 000 Rev.C

COMPONENTS	
BF	24V BATTERY
BE1	BEACON (OPT)
BZ1	REW BUZZER
C1	BATTERY CONNECTOR
CH	BATTERY CHARGER (OPT)
EB1	HOUR METER & BATT. DISPLAY
EB2	DRIVE ELECTRONIC BOARD
ES0	START RELAIS
ES1	MAIN BRUSH ELECTROM. SWITCH
ES2	SHAKER RELAIS
ES3	VACUUM ELECTROM. SWITCH (OPT)
FA	MAIN BRUSH CIRCUIT BREAKER
FL	DRIVE BOARD FUSE (3A)
FT	DRIVE CIRCUIT BREAKER
F1	SERVICES (MAIN) FUSE (25A)
F2	SHEAKER FUSE (25A)
F3	VACUUM FUSE (40A) (OPT)
F4	HORN AND BEACON FUSE (10A) (OPT)
F5	WORKING LIGHT FUSE (10A) (OPT)
F6	SIDE BRUSHES FUSE (10A)
HNI	HORN
K1	KEY
L1	WORKING LIGHT (OPT)
M1	MAIN BRUSH MOTOR
M2	DRIVE MOTOR
M3	SHEAKER MOTOR
M4	RIGHT BRUSH MOTOR
M5	LEFT BRUSH MOTOR (OPT)
M6	VACUUM MOTOR (OPT)
P1	HORN BUTTON
R1	DRIVE SPEED POTENTIOMETER
SWC	HOOD SAFETY MICROSWITCH
SW5	SAFETY SWITCH
SW1	BRUSHES AND SHEAKER SWITCH
SW2	SEAT SAFETY SWITCH
SW4	SIDE BRUSHES MICROSWITCH
SW5	DRIVE SWITCH
SW6	VACUUM SWITCH (OPT)
SW7	WORKING LIGHT SWITCH (OPT)

Pos.	Product no	QTY	Description	Notes
BE1	146 2659 000		BEACON FLASHING KIT	
BZ1	146 2661 000		ALARM BACK UP KIT	
C1	146 1986 000		CONNECTOR 120A RED	
CH1	146 2131 000		CHARGER BATT. ON BOARD 24V 25A 230V CPL	
CH1	1466315000		CHARGER BATT. ON BOARD 24V 13A 230V SIP	
EB1	1466161000		CONTROLLER MAIN MACHINE KIT	
EB2	1466174000		CONTROLLER DRIVE WHEEL SIP	
ES0	146 1646 000		RELAY 24V	
ES1	146 0719 000		SWITCH ELECTROMAGNETIC 24V	
ES2	145 3712 000		RELAY 24V	
FA	909 5706 000		CIRCUIT BREAKER 30A	
FT	909 5706 000		CIRCUIT BREAKER 30A	
F1	145 8514 000		FUSE BLADE 25A	
F2	145 8514 000		FUSE BLADE 25A	
F3	145 0227 000		FUSE BLADE 40A	
F4	1467034000		FUSE BLADE 10A SIP	
F5	1467034000		FUSE BLADE 10A SIP	
F6	1467034000		FUSE BLADE 10A SIP	
HN1	1467032000		HORN 24V 112DB SIP	
K1	33020442		SWITCH IGNITION STARTER W/SPARE KEY KIT	
L1	146 2663 000		LIGHT WORKING KIT	
M1	1467528000		MOTOR ELECTRIC 600W 24V SIP	
M2	146 2166 000		REDUCTION GEARMOTOR 4000W 24V KIT	
M3	1466314000		MOTOR FILTER SHAKER 12W 24V KIT	
M4	1464152000		REDUCTION GEARMOTOR 60W 24V	
M5	1464152000		REDUCTION GEARMOTOR 60W 24V	
P1	145 9678 000		SWITCH PUSH BUTTON F HORN	
R1	146 2952 000		PEDAL SPEED CONTROL KIT	
SWC	146 0565 000		SWITCH PUSH BUTTON	
SWS	1466683000		SWITCH EMERGENCY KIT	
SW1	146 1935 000		SWITCH	
SW4	1466506000		MICROSWITCH 15A 250V SIP	
SW7	146 1974 000		SWITCH	

