

PARTS LIST

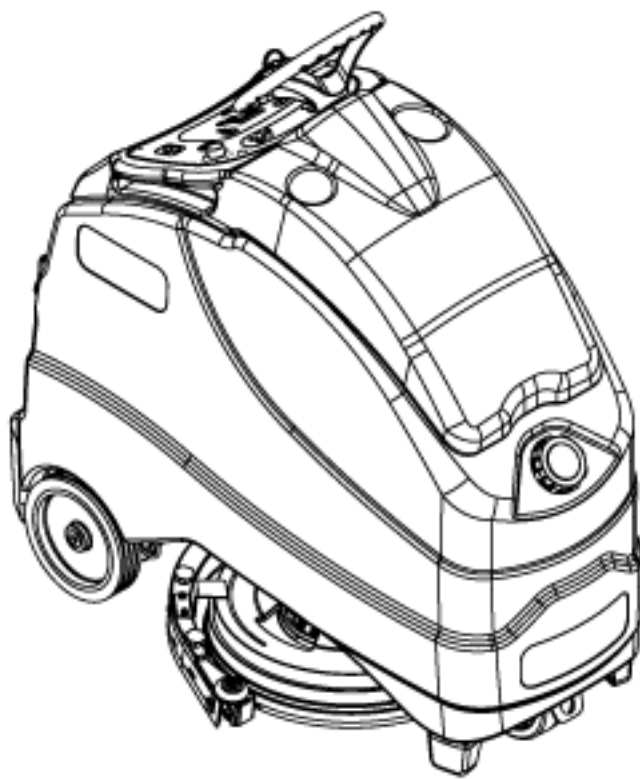

2020.11.19

TABLE OF CONTENTS

GENERAL VIEW	1
Chassis System	3
Control-system	6
DECAL SYSTEM	8
Drive-wheel	10
ELECTRICAL SYSTEM	13
Ladder Diagram-1 after June 2014	16
Ladder Diagram-2 after June 2014	18
RECOVERY SYSTEM	20
Ladder Diagram-1 before July 2014	23
Ladder Diagram-2 before July 2014	25
PLATFORM ASSEMBLY	27
SQUEEGEE SYSTEM	29
SCRUB SYSTEM 20D (2)	32
SCRUB SYSTEM-20D	34
SOLUTION SYSTEM	36
SQUEEGEE BLADE SELECTOR GUIDE	39
OPTIONAL KITS AND ACCESSORIES	41
BRUSH SELECTOR GUIDE	43
RECOMMENDED SPARE PARTS	45
RECOMMENDED SPARE PARTS CONTINUED	50
56104441 DRIVE WHEEL MOUNTING KIT	53
56104192 KIT-ECOFLEX EU	55
56104403 - ONBOARD CHARGER KIT-EU	57
56383814 and 56383748 Trackclean kit	59
IS56090123_56104437 KIT-SHELF CHARGER ADAPTER	61
IS56090254 - 56384040 PLATFORM EXTENSION KIT	63
56384204 KIT-CONTROL BOARD	65
56385136 DRIVE MOTOR HARNESS ASSEMBLY KIT	67
56385105 TANK SUPPORT KIT	69
56385490 HARNESS BATTERY - PANEL ASSEMBLY KIT	71

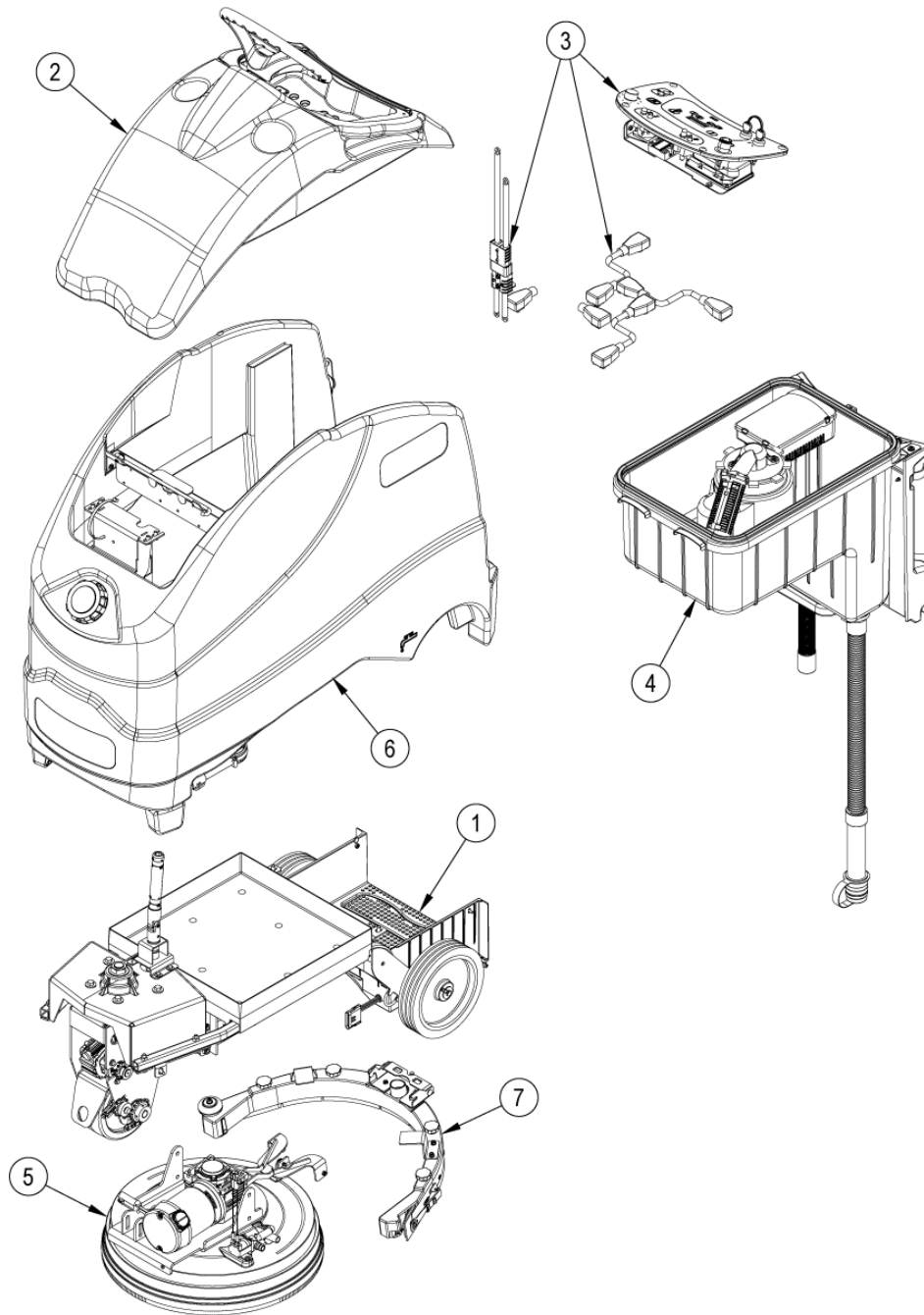

Pos.	Product no	QTY	Description	Notes
1		1	Chassis System	[1]
2		1	Control System	[2]
3		1	Electrical System	[3]
4		1	Recovery System	[4]
5		1	Scrub System-20D	[5]
6		1	Solution System	[6]
7		1	Squeegee Assy	[7]

Part Notes:

- [1] - Chassis System
- [2] - Control-system
- [3] - ELECTRICAL SYSTEM
- [4] - RECOVERY SYSTEM
- [5] - SCRUB SYSTEM-20D
- [6] - SOLUTION SYSTEM
- [7] - SQUEEGEE SYSTEM

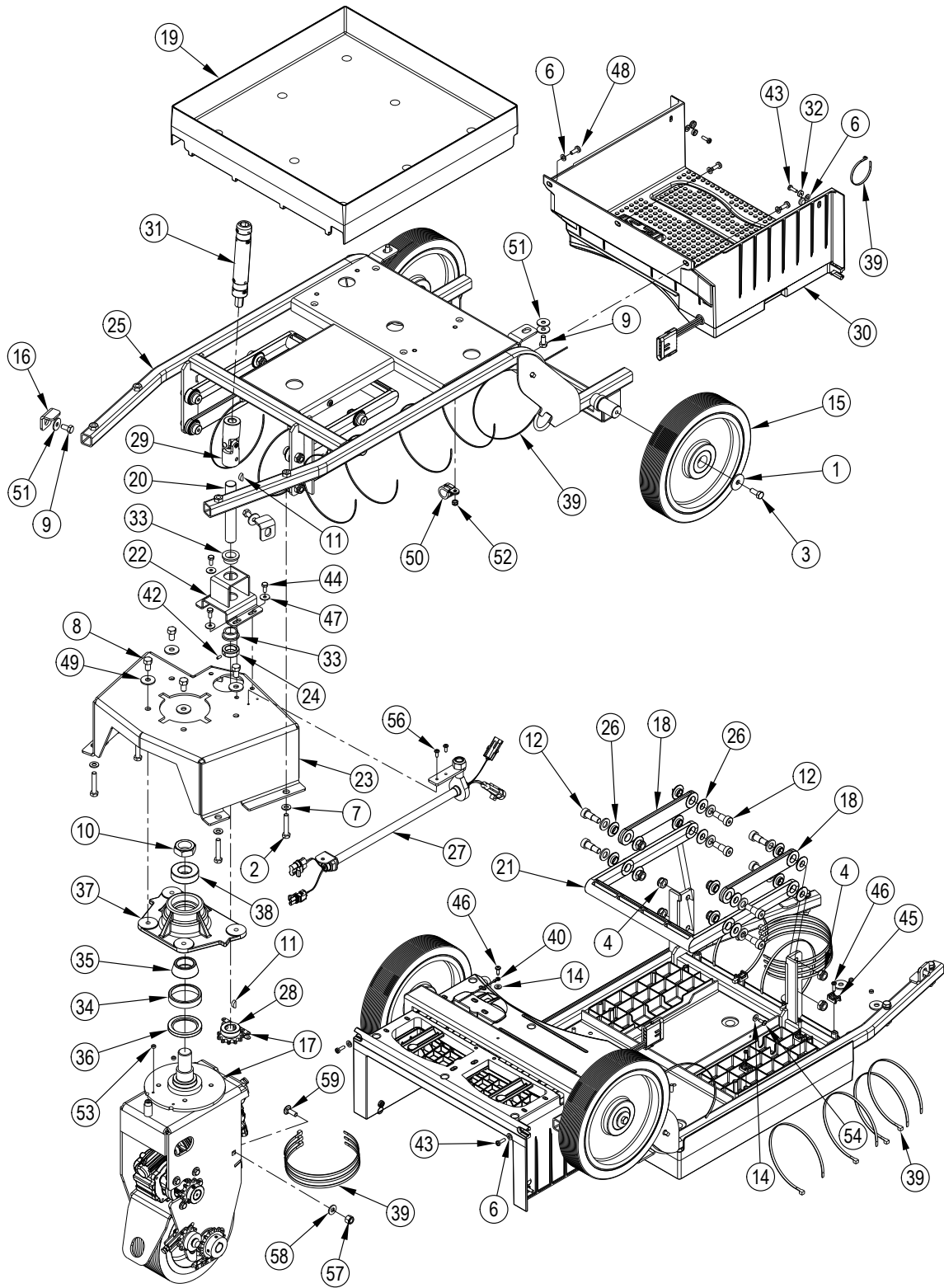

Pos.	Product no	QTY	Description	Notes
1		2	Washer Flat XI 9.0 x 32.0 x 2.5	[1]
2		4	Screw, Hex Hd M8 x 45-	[2]
3		2	Screw, Hex Thd To Hd M8 x 20 SS	[1]
4		8	Nut, M10-1.5 Nylock	[2]
5			Intentionally Omitted	
6		7	Washer, Flat 6.4 X 12,5	[2]
7		4	Washer, Flat 8.4 X 16 X 1.6	[2]
8		4	Scr-Hex Hd Loc 3/8-16 x .62	[2]
9		4	Scr-Hex M8-1.25 X 16MM	[2]
10		1	Nut, Hex Nyl Loc-Thin 1-14	[2]
11		2	Key-Wdf 5MMX6.5MMX16MM	[2]
12		8	Scr-Soc-Shd-M12X20MM-M10 THD	[2]
14		2	Wsh, Int Shprf #10	[2]
15		2	Wheel	[3]
16	56104091	2	MOUNTING TAB	
17		1	Drive Wheel Assembly	
18	56104094	2	BAR-LINKAGE	
19	56104105	1	BATTERY TRAY	
20	56104130	1	STEERING SHAFT	
21	56104135	1	LINK BAR	
22	56104148	1	STEERING SHAFT WELDT	
23	56104151	1	SPINDLE MOUNT WELDMENT	
24	56104157	1	COLLAR	
25	56104448	1	CHASSIS WELDMENT	[4]
26		16	Bushing Link Arm	[2]
27		1	Harness-Drive Motor Kit	[2]
28	56104269	1	SPROCKET-11 TOOTH	
29		1	Universal Joint	[5]
30		1	Platform Assembly	
31	56104319	1	TUBE-STEERING ASSEMBLY	[6]
32		2	Screw Cap	[2]
33	56104267	2	BEARING FLANGE	
34		1	Bearing Cup	[7]
35		1	Bearing Cone	[7]
36		1	Seal, Shaft	[7]
37	56314032	1	BLOCK BEARING	
38		1	Bearing Ball	[7]
39		12	Tie, 8" Black	[2]
40		1	Chain - Ball	[2]
42		1	Screw Grub M5 x 10 Uni5929	[2]
43		4	Scr, Pan Phil M5 x 16	[2]
44		3	Screw, Hex Thd To Hd M6 x 14	[2]
45		5	Flat Tie Holder	[2]
46		5	Thread Rolling Scr 5 X 16	[2]
47		3	Washer, Flat XI	[2]
48		3	Scr-Pan Phil M6-1 X 16MM	[2]
49		4	Washer, Flat XI 9.5 X 27 X 2.5	[2]
50	909 5516 000	1	CLAMP HOSE D.18	
51		6	Washer Flat XI Uni-6593 8 x 24	[2]
52	33023667	1	NUT LOCK HEX M6 LOW ISO10511 5 PCS SET	
53	9099196000	2		
54		2	Scr 4.8 X 16 UNI6954 Thd Form	[2]
55			Intentionally Omitted	
56		2	Scr Pan Phil 10-24 X .50	[8]
57		1	Nut-Hex Nyl Loc SS.25-20	[8]
58		1	Wsh-Ext-Ser-SS-.25	[8]
59		2	Scr-Carr-SS-1/4-20X.675	[8]
60		1	15.35 in Cable Tie Black Nylon	[8]
			SERVICE KITS	

Pos.	Product no	QTY	Description	Notes
K1	56104328	1	UNIVERSAL JOINT KIT	
K2	56104331	1	REAR WHEEL KIT	
K3	56104332	1	BEARING BLOCK KIT	
K4	56104333	1	CHASSIS HARDWARE KIT	
K5	56385136	1	HARNESS DRIVE MOTOR ASSY KIT	[9]

Part Notes:

- [1] - K2,K4
- [2] - K4
- [3] - K2
- [4] - NON-SALEABLE
- [5] - K1
- [6] - TSB-FC-2014-002 SC1500 Axle
- [7] - K3
- [8] - K5
- [9] - TSB-FC-2018-001 SC1500_SA40 Loss of Drive
DE TSB-FC-2018-001 SC1500 Fahrtrieb ohne Funktion

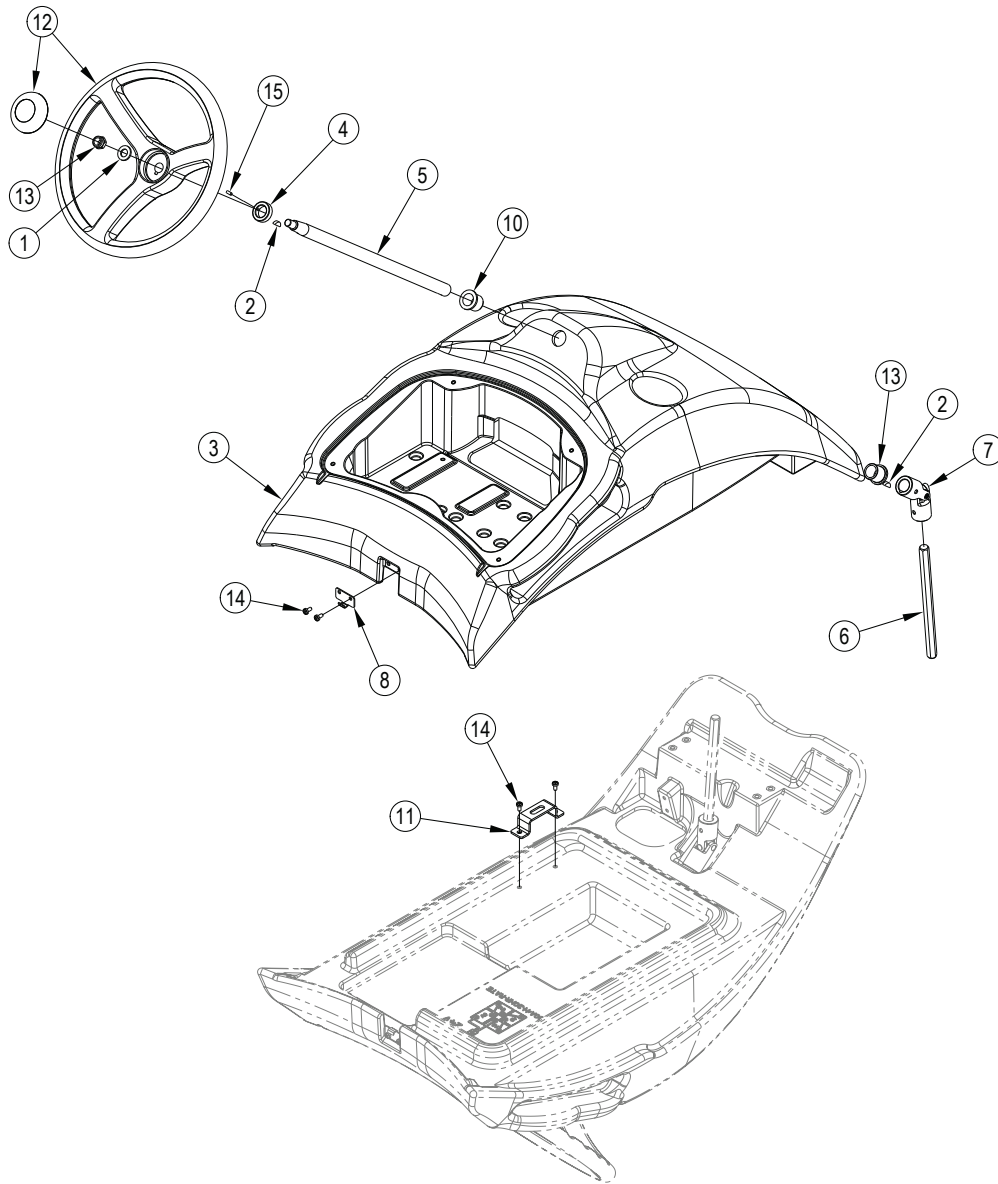

Pos.	Product no	QTY	Description	Notes
1		1	WASHER, FLAT 13X24	
2		2	KEY-WDF 5MMX6.5MMX16MM	
3	56104053	1	CONTROL PANEL	
4		1	COLLAR	
5	56104196	1	SHAFT STEERING	
6	56104265	1	SHAFT HEX	
7		1	UNIVERSAL JOINT	
8		1	HOOK LATCH	
10		2	BEARING-FLANGE	
11	56104410	1	BRACKET-PROP ROD	
12	56601060	1	STEERING WHEEL	
13		1	NUT, HEX NYL LOC THIN M12	
14		4	SCR, PAN PHIL M5X10 SS	
15		1	SCREW GRUB M5X10 UNI5929	
K1	56104328	1	UNIVERSAL JOINT KIT	[1]
K2	56104352	1	DRAW LATCH KIT	[2]
K3	56104365	1	CONTROL HARDWARE KIT	[3]

Part Notes:

- [1] - Includes pos. 7
- [2] - Includes pos. 8,14
- [3] - Includes pos. 1,2,4,9,13,14

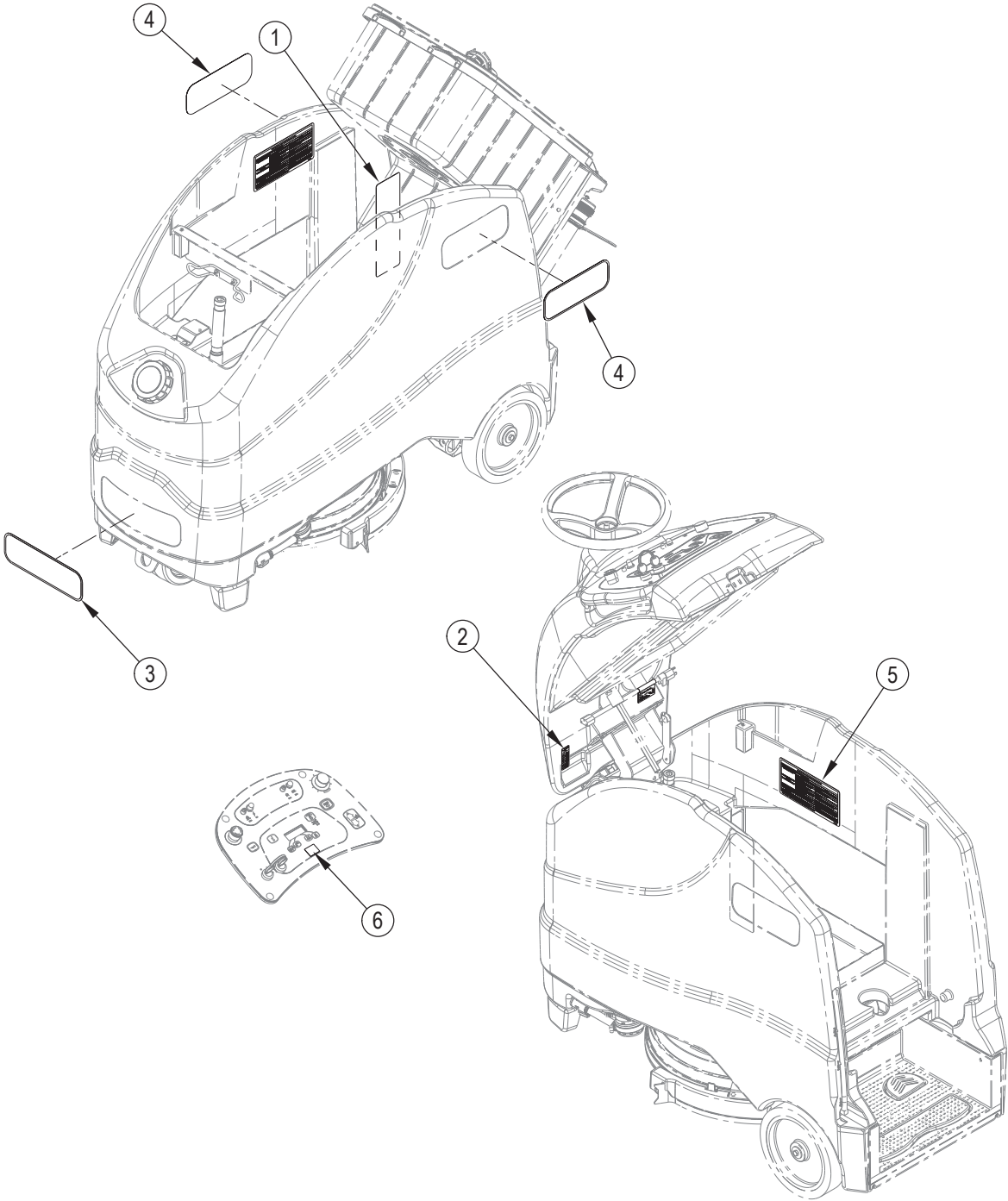

Pos.	Product no	QTY	Description	Notes
1		1	Decal, Caution	
2		1	Decal-Chemical Ratio	
3		1	Decal, Nilfi sk	
4		2	Decal-Nilfi sk Sc1500	
5		1	Decal-Error Codes	
6		1	Decal-SC1500 QR Code	
K1	56104335	1	SC1500 EU DECAL KIT	[1]
K2	56104481	1	SC1500 EU ECOFLEX DECAL KIT	
K2	56104348	1	DECAL SC1500 REV KIT	

Part Notes:

[1] - Includes pos. 1-6

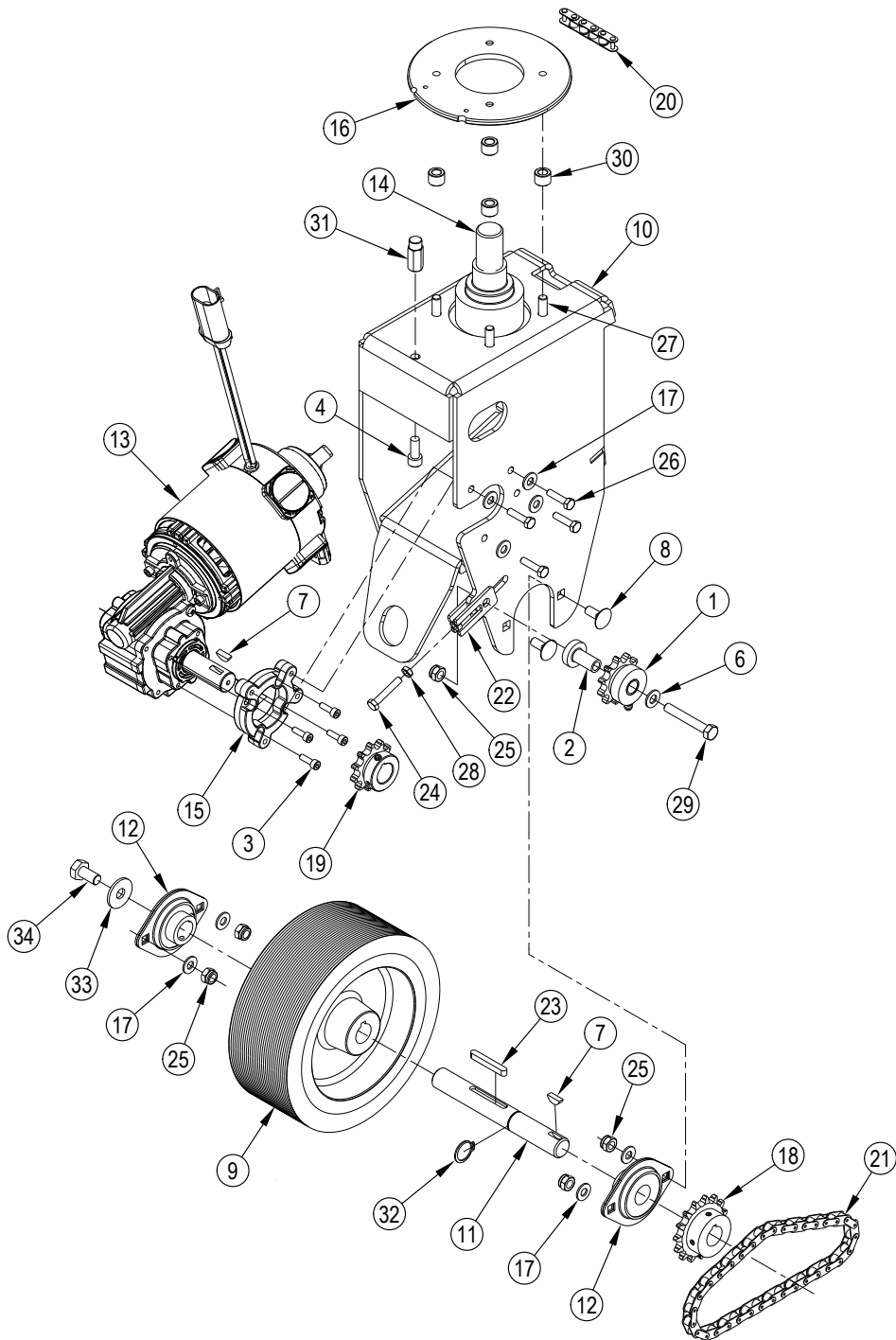

Pos.	Product no	QTY	Description	Notes
1		1	SPROCKET ASSY	[1]
2		1	BUSHING, FLANGED	[2]
3		4	VITI TCEI/SCR, SOC HD	[3]
4		1	SCR-SOC HD 5/16-18 X 1.50	[4]
6		1	WSH-FLT SAE SS 5/16	[2]
7	56003877	2	KEY-WDF 5X6.5 DIN 6888	[5]
8		4	SCR-CARRIAGE SS M8-1.25 X 20MM	[6]
9		1	DRIVE WHEEL	[7]
10	56104793	1	DRIVE WHEEL FRAME WELDMENT	[8]
10	56104498	1	DRIVE WELDMENT KIT	[9]
11		1	AXLE	[10]
12		2	AXLE BEARING	[11]
13		1	DRIVE WHEEL MOTOR (M1)	[12]
	56384100	1	ELECTOMAGNETIC BRAKE KIT	[13]
14	56104077	1	SPINDLE WELDT	
15		1	SPACER	[14]
16	56104115	1	STEERING PLATE	
17		8	WASHER, FLAT 8X17X1.6 SS	[15]
18		1	SPROCKET-15 TOOTH	[16]
19		1	SPROCKET-11 TOOTH	[16]
20	56104270	1	CHAIN-ROLLER	
21		1	CHAIN-ROLLER	[17]
22		1	WELD'T-IDLER ADJUST	[17]
23	56314359	1	KEY 6MM SQUARE	[7]
24		1	SCREW, HEX THD TO HD M6X35 SS	[2]
25		5	NUT, HEX NYL LOC THIN M8 SS	[15]
26		4	SCREW, HEX THD TO HD M6X25 SS	[18]
27		4	SCREW, HEX THD TO HD M8X30 SS	[19]
28		1	Nut, Hex M6 Ss	[2]
29		1	SCREW, HEX THD TO HD M8X55 SS	[2]
30		4	SPACER	[19]
31		1	SPACER	[4]
32	9100001346	1	RING D 20 UNI7435 10 PCS SET	[10]
33	56002910	1	WSH FLT SAE SS 3/8	[10]
34	56003533	1	SCR HEX SS M10-1.50X20MM	[10]
			SERVICE KITS	
K5	56104336	1	DRIVE WHEEL MOTOR KIT	[20]
K6	56104338	1	KIT-WHEEL AND BEARING	[21]
K7	56104435	1	SPROCKET AND CHAIN KIT	[22]
K7	56104339	1	SPROCKET AND CHAIN KIT	[23]
K8	56104340	1	DRIVE WHEEL HARDWARE KIT	[24]
K9	56104384	1	FRONT WHEEL BEARINGS KIT	[25]

Part Notes:

- [1] - TSB-FC-2013-132 SC1500 Drive Wheel Sprocket
K7
- [2] - K7,K8
- [3] - K5,K8
- [4] - K8,K10
- [5] - K5,K6,K7
- [6] - K6,K8,K9
- [7] - K6
- [8] - (used after September 2013)
- [9] - (used before October 2013)
- [10] - TSB-FC-2014-002 SC1500 Axle
K6
- [11] - K6,K9
- [12] - TSB-FC-2015-012 SC1500 Wire Harness Routing
K5

-
- [13] - Electromagnetic Brake Kit 56384100 can be used to replace Brake-Electromagnetic 56384098 as a separate repair part for the Drive Wheel Motor.

 - TSB-FC-2015-012 SC1500 Wire Harness Routing
 - [14] - K5
 - [15] - K5,K6,K8,K9
 - [16] - TSB-FC-2013-132
K7
 - [17] - K7
 - [18] - K5,K6,K8
 - [19] - K8
 - [20] - Includes pos. 3,7,13,15,17,26,
 - [21] - Includes pos. 7,8,9,11,12,17,25,26
 - [22] - (used with 56104431)

Includes pos. 1,2,6,4,18,19,21,22,24,25,28,29
 - [23] - (used with 56104498)

Includes pos. 1,2,6,4,18,19,21,22,24,25,28,29
 - [24] - Includes pos. 2,3,4,8,6,8,17,24-31
 - [25] - Includes pos. 8,12,17,25

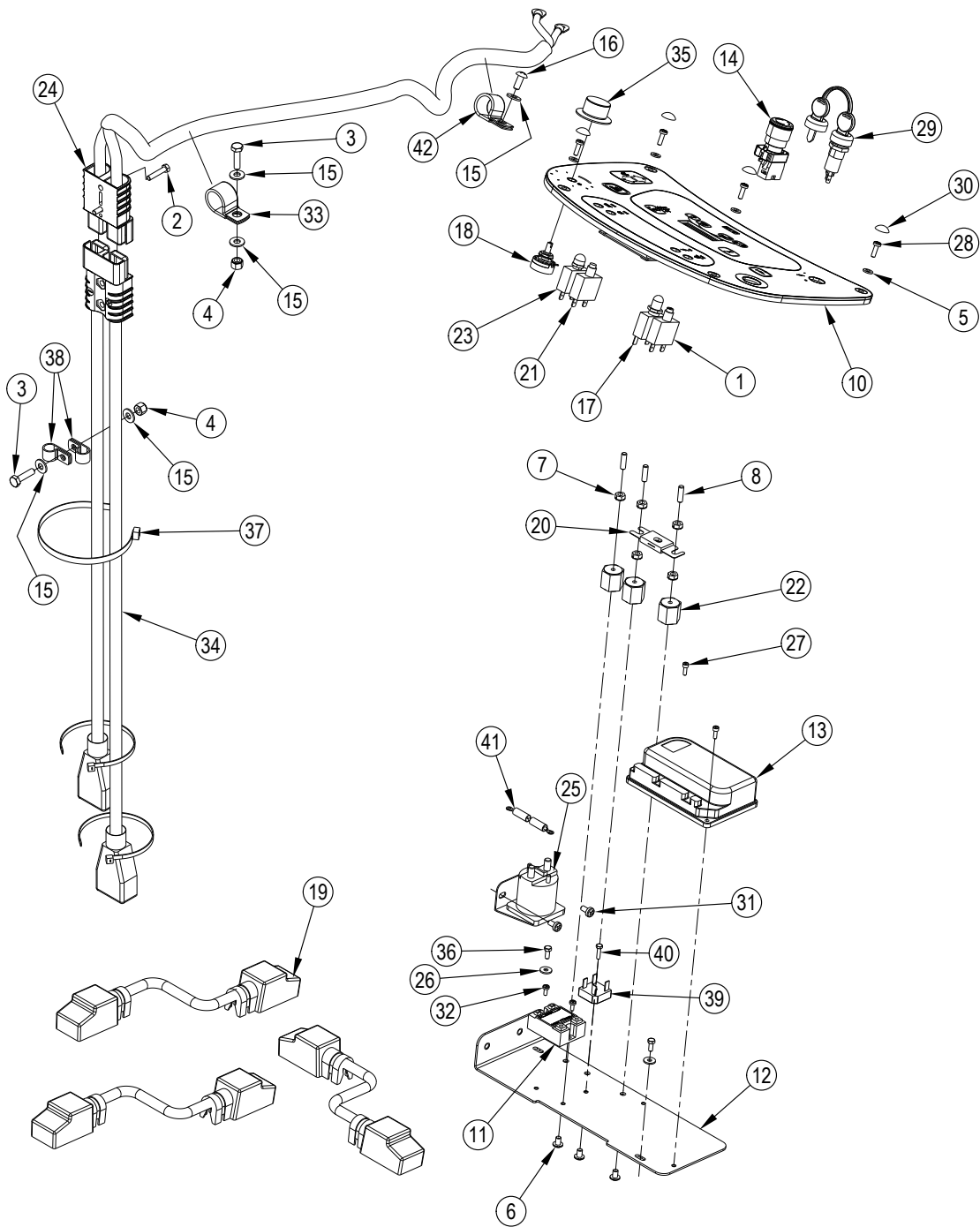

Pos.	Product no	QTY	Description	Notes
1	56104423	1	CIRCUIT BREAKER-50 AMP	[1]
2	33003964	2	SCREW M5X25 HEX HD F/THD ISO4017	
3	56002093	2	SCR HEX 1/4-20 X 1.00Scr-Hex 1/4-20 X 1.00	
4	56002708	2	NUT HEX NYL LOC 1/4-20Nut, Hex Nyl Loc 1/4-20	
5		4	Washer, Flat 6,4x12,5	
6		3	Scr-Pan Phil 1/4-20 X .38	[2]
7		5	Nut, Hex W/ Shprf 1/4-20	[2]
8		3	Stud	[2]
9	56104444	1	HARNES-MAIN	
10		1	Interface Panel Assembly	[3]
		1	Interface Panel Kit	[4]
11	56104176	1	SOLID STATE RELAY	
12	56104193	1	ELECTRICAL PANEL	
13	56104243	1	SPEED CONTROLLER	
14	56104247	1	DISCONNECT-EMERGENCY	
15	56002859	5	WSH FLT SAE SS 1/4	
16	56009120	1	SCR PANPHIL SS TYPEB1/4-14X.62	
17	56315255	1	CIRCUIT BREAKER 5 AMP	[5]
18		1	Potentiometer, 100k	[6]
19	56104438	3	CABLE-BATTERY ASSY	
20	56412089	1	FUSE 150 AMP	
21	56413822	1	CIRCUIT BREAKER 20 AMP	[7]
22	56469858	3	ELECTRICAL MOUNT	
23	56509623	1	CIRCUIT BREAKER-25 AMP	[8]
24	56104281	1	CABLE-POWER	
25	56601183	1	CONTACTOR 24V 100 AMP	
26		2	Washer, Flat XI 5,5x15x1,2 Ss	[2]
27		2	Viti Tcei/Scr, Soc Hd	[2]
28		4	Scr, Pan Phil M5x16	[2]
29	146 2888 000	1	SWITCH IGNITION STARTER WITH CAP	
	146 2887 000	1	KEY 2 PCS	
30		4	Cover For Screw Tcb 4.8mm	[2]
31		2	Screw, M6 X 1.00 X 10MM Pan Head	[2]
32		2	Scr, Pan Phil M4x10	[2]
33	56303651	1	CLAMP P CL-16Clamp, Hose Support	
34	56104439	1	CABLE-CONNECTOR ASSY	
35	50962A	1	KNOB CONTROL ENCORE 2426	
36		2	Screw, Hex THD TO HD M5x12	[2]
37	56477613	1	CABLE TIE E00549 RE409S+Tie, Cable	
38	56486112	2	CLAMP PClamp-P	
39	56265103	1	RECTIFIER 35 AMP	
40	1460497000	1	SCREW HEX HD M4X16 SS	
41	56389265	1	RECTIFIER ASSY.	[9]
42	56496276	1	CLAMP HOSE SUPPORTClamp, Hose Support	
43	56385490	1	BATT PANEL HARNES ASSY KIT	[10]
	56104425	1	WIRE ASSY WHITE	
	56104424	1	WIRE ASSY BLACK	
		1	IS56090357. HARNES BATTERY - PANEL ASSEMBLY KIT 56385490	[11]
			SERVICE KITS	
K1	56104341	1	ELECTRICAL HARDWARE KIT	
K2	56384204	1	USER INTERFACE KITControl Board Kit	
K3	56104372	1	INTERFACE PANEL KIT	

Part Notes:

- [1] - CB1
 [2] - K1
 [3] - K2

A1

- [4] - K3
- [5] - CB2
- [6] - R1 / part of Main harness
- [7] - CB3
- [8] - CB4
- [9] - TSBUS2003-843
- [10] - TSB-FC-2018-010 SC1500_SA40 Battery Harness Upgrade
- [10] - DE TSB-FC-2018-010 SC1500 Verbesserung des Batteriekabelbaums
- [11] - IS56090357. HARNESS BATTERY - PANEL ASSEMBLY KIT 56385490

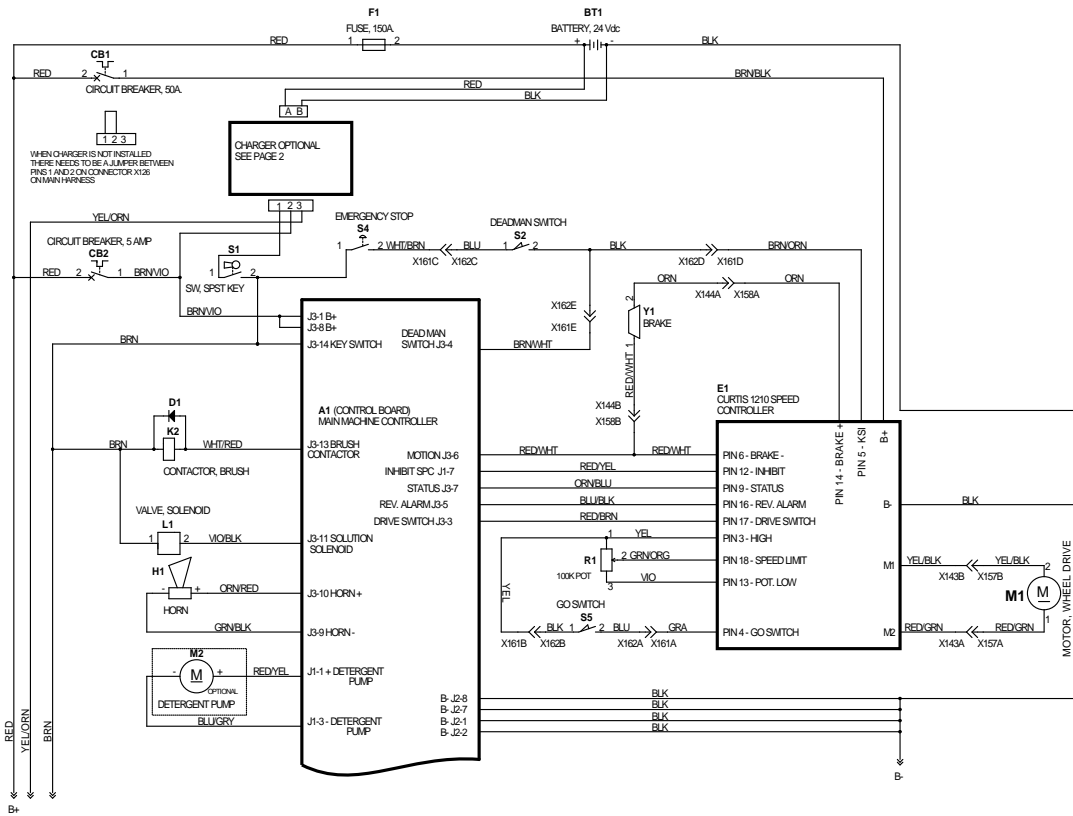

Pos.	Product no	QTY	Description	Notes
A1			Control Board	
BT1			Battery	
CB1	56104423	1	CIRCUIT BREAKER-50 AMP	[1]
CB2	56315255	1	CIRCUIT BREAKER 5 AMP	[2]
CB3	56413822	1	CIRCUIT BREAKER 20 AMP	[3]
CB4	56509623	1	CIRCUIT BREAKER-25 AMP	[4]
D1	56389265	1	RECTIFIER ASSY.	[5]
D2	56265103	1	RECTIFIER 35 AMP	
E1	56104243	1	SPEED CONTROLLER	
E2	56114378	1	BATTERY CHARGER 24V 25A	
E2	56383856	1	CHARGER-ONBOARD 24V 650W	[6]
F1	56412089	1	FUSE 150 AMP	
H1	909 6126 000	1	BUZZER 3-28V DC	
K1	56104176	1	SOLID STATE RELAY	
K2	56601183	1	CONTACTOR 24V 100 AMP	
L1	56104169	1	SOLENOID VALVE ASSY	
M1		1	Drive Wheel Motor	
M2	56315241	1	PUMP CHEMICAL	
M3	56104356	1	ACTUATOR KIT	[7]
M4	909 7556 000	1		
M5	56104071	1	DISC BRUSH MOTOR	
R1		1	Potentiometer 100k	
S1	9100001354	1	SWITCH IGNITION STARTER WITH CAP SIP	
	146 2887 000	1	KEY 2 PCS	[8]
S2		1	Switch-Sealed	
S4	56104247	1	DISCONNECT-EMERGENCY	
S5		1	Switch-Sealed	[8]
Y1			Electrical Brake	[9]

Part Notes:

- [1] - Drive Wheel
- [2] - Control Circuit
- [3] - Vacuum Motor
- [4] - Brush Motor
- [5] - TSBUS2003-843
- [6] - EXPIRED USE 56122805
- [7] - Motor Brush Lift Actuator
- [8] - part of Switch Harness 56104406
- [9] - part of Drive Wheel Motor M1

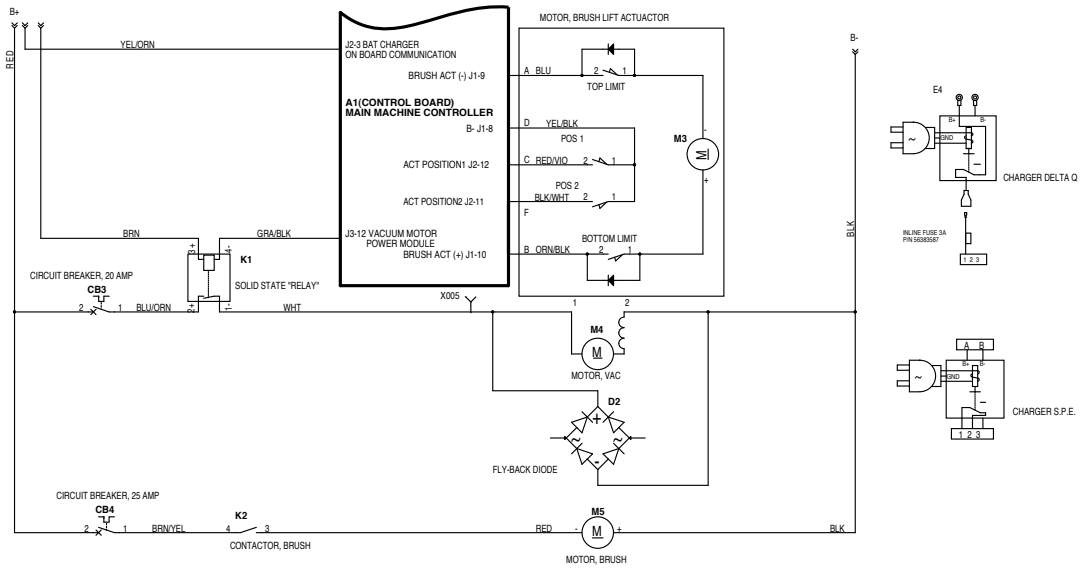

Pos.	Product no	QTY	Description	Notes
A1			Control Board	
BT1			Battery	
CB1	56104423	1	CIRCUIT BREAKER-50 AMP	[1]
CB2	56315255	1	CIRCUIT BREAKER 5 AMP	[2]
CB3	56413822	1	CIRCUIT BREAKER 20 AMP	[3]
CB4	56509623	1	CIRCUIT BREAKER-25 AMP	[4]
D1	56389265	1	RECTIFIER ASSY.	[5]
D2	56265103	1	RECTIFIER 35 AMP	
E1	56104243	1	SPEED CONTROLLER	
E2	56114378	1	BATTERY CHARGER 24V 25A	
E2	56383856	1	CHARGER-ONBOARD 24V 650W	[6]
F1	56412089	1	FUSE 150 AMP	
H1	909 6126 000	1	BUZZER 3-28V DC	
K1	56104176	1	SOLID STATE RELAY	
K2	56601183	1	CONTACTOR 24V 100 AMP	
L1	56104169	1	SOLENOID VALVE ASSY	
M1	56104074	1	DRIVE WHEEL MOTOR	
M2	56315241	1	PUMP CHEMICAL	
M3	56104356	1	ACTUATOR KIT	[7]
M4	909 7556 000	1		
M5	56104071	1	DISC BRUSH MOTOR	
R1		1	Potentiometer 100k	[8]
S1	9100001354	1	SWITCH IGNITION STARTER WITH CAP SIP	
	146 2887 000	1	KEY 2 PCS	
S2		1	Switch-Sealed	[9]
S4	56104247	1	DISCONNECT-EMERGENCY	
S5		1	Switch-Sealed	[9]
Y1			Electrical Brake	[10]

Part Notes:

- [1] - Drive Wheel
- [2] - Control Circuit
- [3] - Vacuum Motor
- [4] - Brush Motor
- [5] - TSBUS2003-843
- [6] - EXPIRED USE 56122805
- [7] - Motor Brush Lift Actuator
- [8] - Speed Adjustment / part of Main harness
- [9] - part of Switch Harness 56104406
- [10] - part of Drive Wheel Motor M1

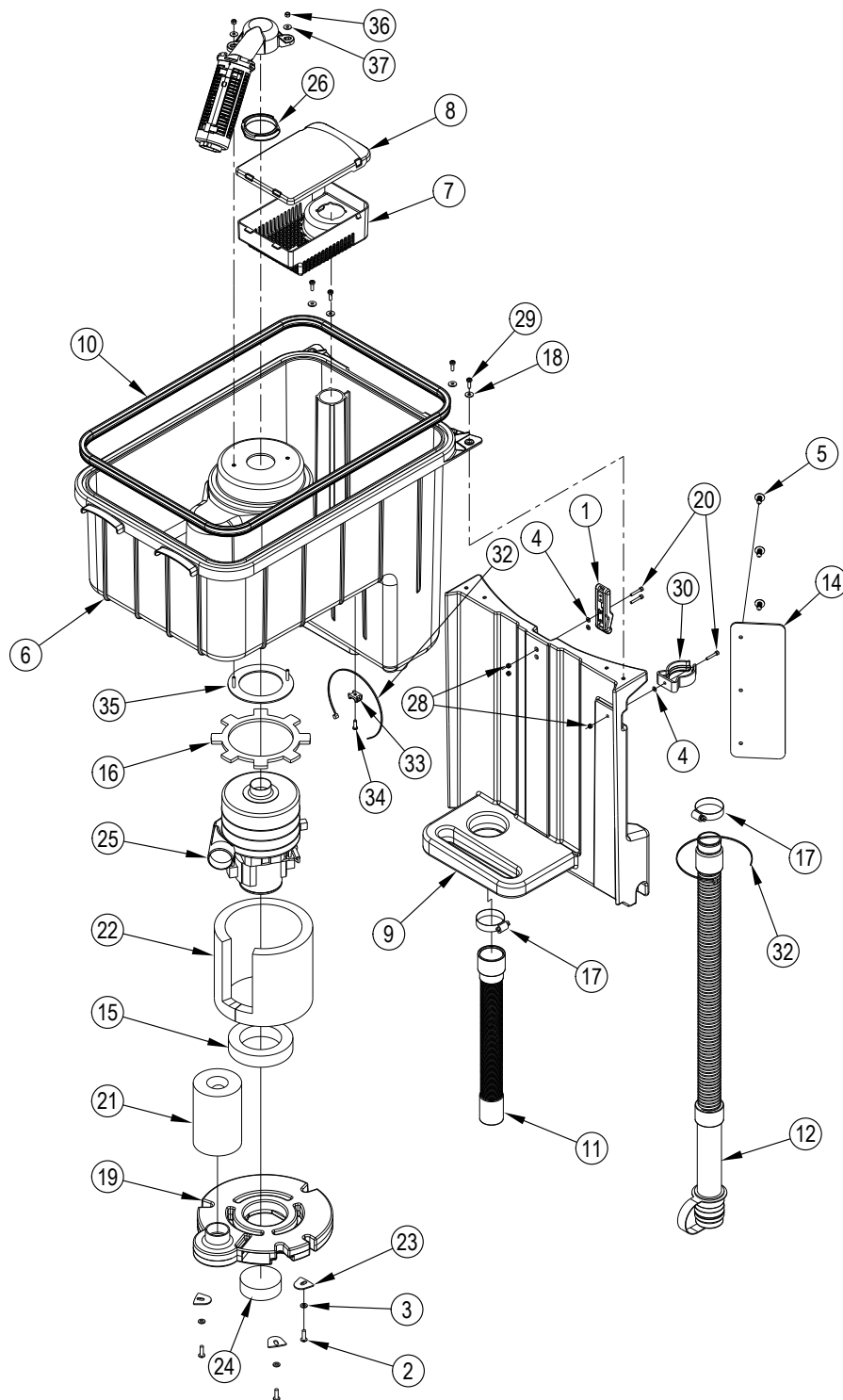

Pos.	Product no	QTY	Description	Notes
1		1	LATCH, DRAW	[1]
2		3	Screw M6x20 Wn1451 Black Zn	[2]
3		3	WASHER, FLAT 6,4X12,5 S.S.	[2]
4		3	WASHER, FLAT 4,3X9	[3]
5		3	RIVET, NYLON TREE PUSH-IN (.25)	[2]
6	56394063	1	RECOVERY TANK KIT	[4]
7		1	DEBRIS CAGE	[5]
8		1	DEBRIS TRAY COVER	[5]
9	56104158	1	BACK PANEL	
10	56104164	1	GASKET-RECOVERY TANK	
11	56104258	1	VAC HOSE ASSY	
12	56104285	1	DRAIN HOSE	
13	56104306	1	HARNES-JUMPER	[6]
14	56104443	1	GUARD-SPLASH-4X12-POLY	
15		1	VACUUM MOTOR SUPPORT GASKET	[7]
16		1	GASKET, VACUUM MOTOR	[8]
17	9100001348	2	CLAMP HOSE 32-52/12 10 PCS SET	
18		4	Washer, Flat XI 5,5x15x1,2 SS	[9]
19	9100001246	1	COVER VACUUM MOTOR	
20		3	VITI TCEI/SCR, SOC HD	[3]
21		1	INSULATION TUBE	[7]
22		1	PANEL, ACOUSTIC INSULATION	[7]
23		3	PLATE COVER	[2]
24	56344168	1	FILTERFILTER	
25		1	VACUUM MOTOR 3 STAGE 24V (M4)	[8]
26		1	Gasket Float Support	[10]
27		1	FLOAT CAGE-COMplete	[10]
28		3	NUT, HEX NYL LOC THIN M4 SS	[3]
29		4	Scr,Pan Phil M5x16 SS	[9]
30		1	CLAMP, HOSE D.50	[11]
31		2	Intentionally Omitted	
32	56478523	1	CABLE TIE E00549	
33	909 6595 000	1	HOLDER.FLAT TIE	
34	9097919000	1	Screw Cyl Hd 5X16 Self L. Plas	
35	56385083	1		
36	56003975	2	NUT HEX NYL LOC SS M5-0.8	
37	56009332	2		
K1	56104352	1	DRAW LATCH KIT	[12]
K3	56104389	1	FLOAT CAGE EU KIT	[13]
K4	56104360	1	DEBRIS CAGE KIT	[14]
K5	56104362	1	HOSE CLAMP KIT	[15]
K6	56104363	1	VACUUM MOTOR KIT	[16]
K7	56104364	1	RECOVERY HARDWARE KIT	[17]
K8	56104383	1	VACUUM MOTOR INSULATION KIT	[18]

Part Notes:

- [1] - K1
- [2] - K7
- [3] - K1,K5,K7
- [4] - To replace an old style recovery tank (PN 56104051) order 56394063 Recovery Tank Kit.
 TSB-FC-2018-008 SC1500 Recovery Tank Cracking
 DE TSB-FC-2018-008 SC1500 Risse am Schmutzwassertank
- [5] - K4
- [6] - NOT SHOWN - TSB-FC-2016-266 SC1500 Vac harness connector
 DE TSB-FC-2016-266 SC1500 Saugmotor Kabelbaum Stecker UPDATE
- [7] - K8
- [8] - K6
- [9] - K3,K7

- [10] - K3
- [11] - K5
- [12] - Includes pos. 1,4,20,28
- [13] - Includes pos. 18,26,27,29
- [14] - Includes pos. 7,8
- [15] - Includes pos. 4,20,28,30
- [16] - Includes pos. 16,25
- [17] - Includes pos. 2,3,4,5,18,20,23,28,29
- [18] - Includes pos. 15,21,22

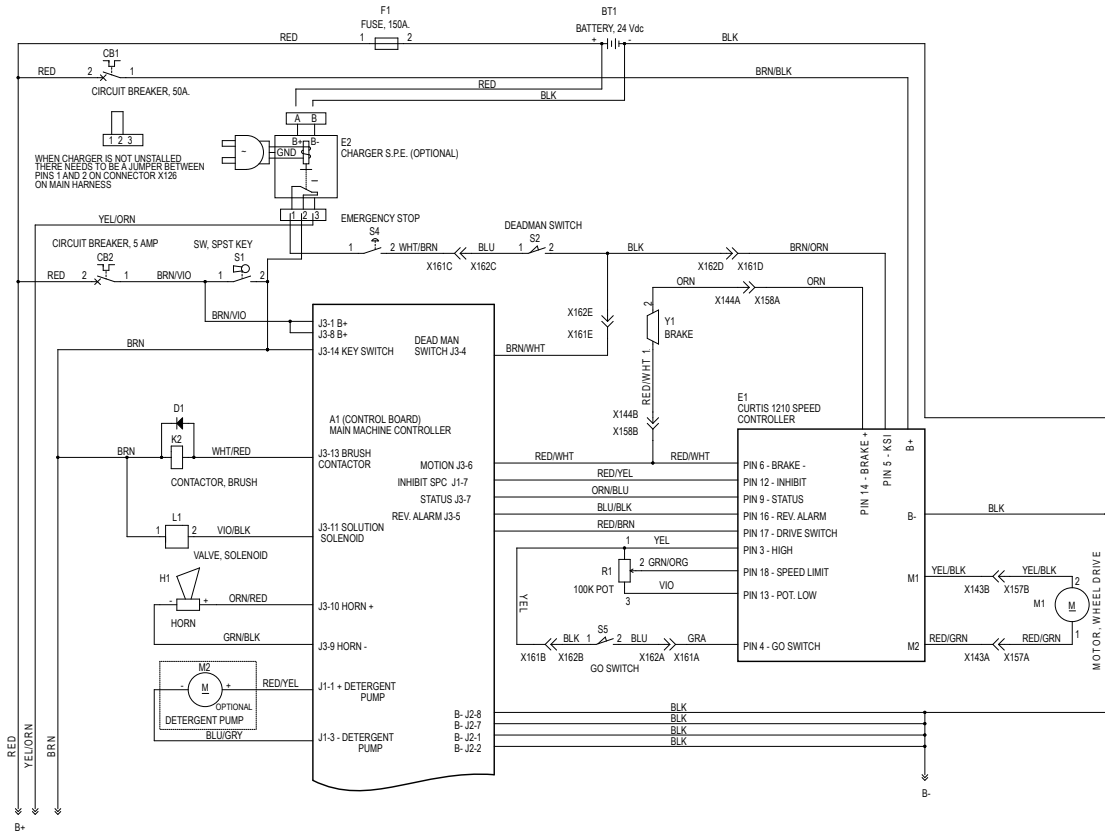

Pos.	Product no	QTY	Description	Notes
A1			Control Board	
BT1			Battery	
CB1	56104423	1	CIRCUIT BREAKER-50 AMP	[1]
CB2	56315255	1	CIRCUIT BREAKER 5 AMP	[2]
CB3	56413822	1	CIRCUIT BREAKER 20 AMP	[3]
CB4	56509623	1	CIRCUIT BREAKER-25 AMP	[4]
D1	56389265	1	RECTIFIER ASSY.	[5]
D2	56265103	1	RECTIFIER 35 AMP	
E1	56104243	1	SPEED CONTROLLER	
E2	56383856	1	CHARGER-ONBOARD 24V 650W	[6]
E2	56114378	1	BATTERY CHARGER 24V 25A	
F1	56412089	1	FUSE 150 AMP	
H1	909 6126 000	1	BUZZER 3-28V DC	
K1	56104176	1	SOLID STATE RELAY	
K2	56601183	1	CONTACTOR 24V 100 AMP	
L1	56104169	1	SOLENOID VALVE ASSY	
M1		1	Drive Wheel Motor	
M2	56315241	1	PUMP CHEMICAL	
M3	56104356	1	ACTUATOR KIT	[7]
M4	909 7556 000	1		
M5	56104071	1	DISC BRUSH MOTOR	
R1		1	Potentiometer 100k	[8]
S1	9100001354	1	SWITCH IGNITION STARTER WITH CAP SIP	
	146 2887 000	1	KEY 2 PCS	
S2		1	Switch-Sealed	[9]
S4	56104247	1	DISCONNECT-EMERGENCY	
S5		1	Switch-Sealed	[9]
Y1			Electrical Brake	[10]

Part Notes:

- [1] - Drive Wheel
- [2] - Control Circuit
- [3] - Vacuum Motor
- [4] - Brush Motor
- [5] - TSBUS2003-843
- [6] - EXPIRED USE 56122805
- [7] - Motor Brush Lift Actuator
- [8] - Speed Adjustment / part of Main harness
- [9] - part of Switch Harness 56104406
- [10] - part of Drive Wheel Motor M1

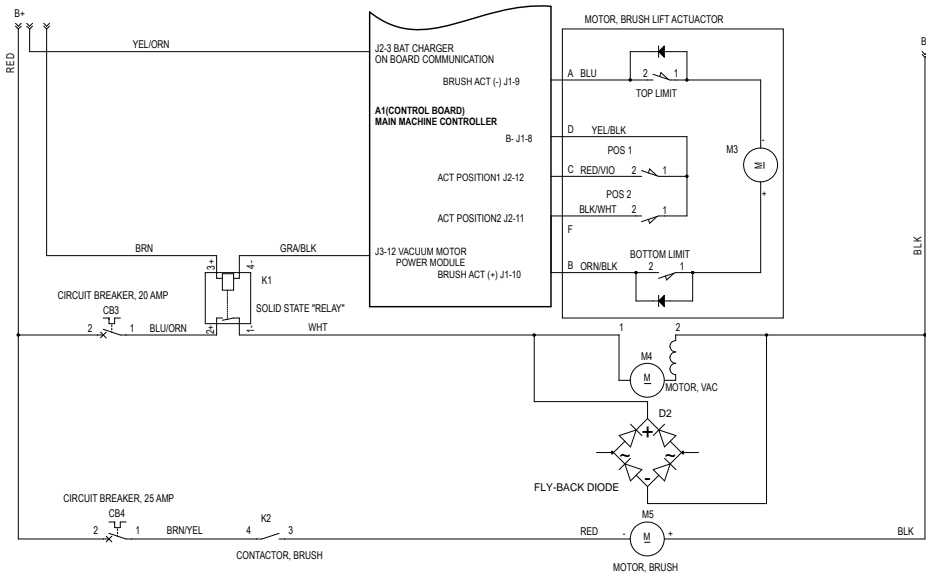

Pos.	Product no	QTY	Description	Notes
A1			Control Board	
BT1			Battery	
CB1	56104423	1	CIRCUIT BREAKER-50 AMP	[1]
CB2	56315255	1	CIRCUIT BREAKER 5 AMP	[2]
CB3	56413822	1	CIRCUIT BREAKER 20 AMP	[3]
CB4	56509623	1	CIRCUIT BREAKER-25 AMP	[4]
D1	56389265	1	RECTIFIER ASSY.	[5]
D2	56265103	1	RECTIFIER 35 AMP	
E1	56104243	1	SPEED CONTROLLER	
E2	56114378	1	BATTERY CHARGER 24V 25A	
F1	56412089	1	FUSE 150 AMP	
H1	909 6126 000	1	BUZZER 3-28V DC	
K1	56104176	1	SOLID STATE RELAY	
K2	56601183	1	CONTACTOR 24V 100 AMP	
L1	56104169	1	SOLENOID VALVE ASSY	
M1	56104074	1	DRIVE WHEEL MOTOR	
M2	56315241	1	PUMP CHEMICAL	
M3	56104356	1	ACTUATOR KIT	[6]
M4	909 7556 000	1		
M5	56104071	1	DISC BRUSH MOTOR	
R1		1	Potentiometer 100k	[7]
S1	9100001354	1	SWITCH IGNITION STARTER WITH CAP SIP	
	146 2887 000	1	KEY 2 PCS	
S2		1	Switch-Sealed	[8]
S4	56104247	1	DISCONNECT-EMERGENCY	
S5		1	Switch-Sealed	[8]
Y1			Electrical Brake	[9]

Part Notes:

- [1] - Drive Wheel
- [2] - Control Circuit
- [3] - Vacuum Motor
- [4] - Brush Motor
- [5] - TSBUS2003-843
- [6] - Motor Brush Lift Actuator
- [7] - Speed Adjustment / part of Main harness
- [8] - part of Switch Harness 56104406
- [9] - part of Drive Wheel Motor M1

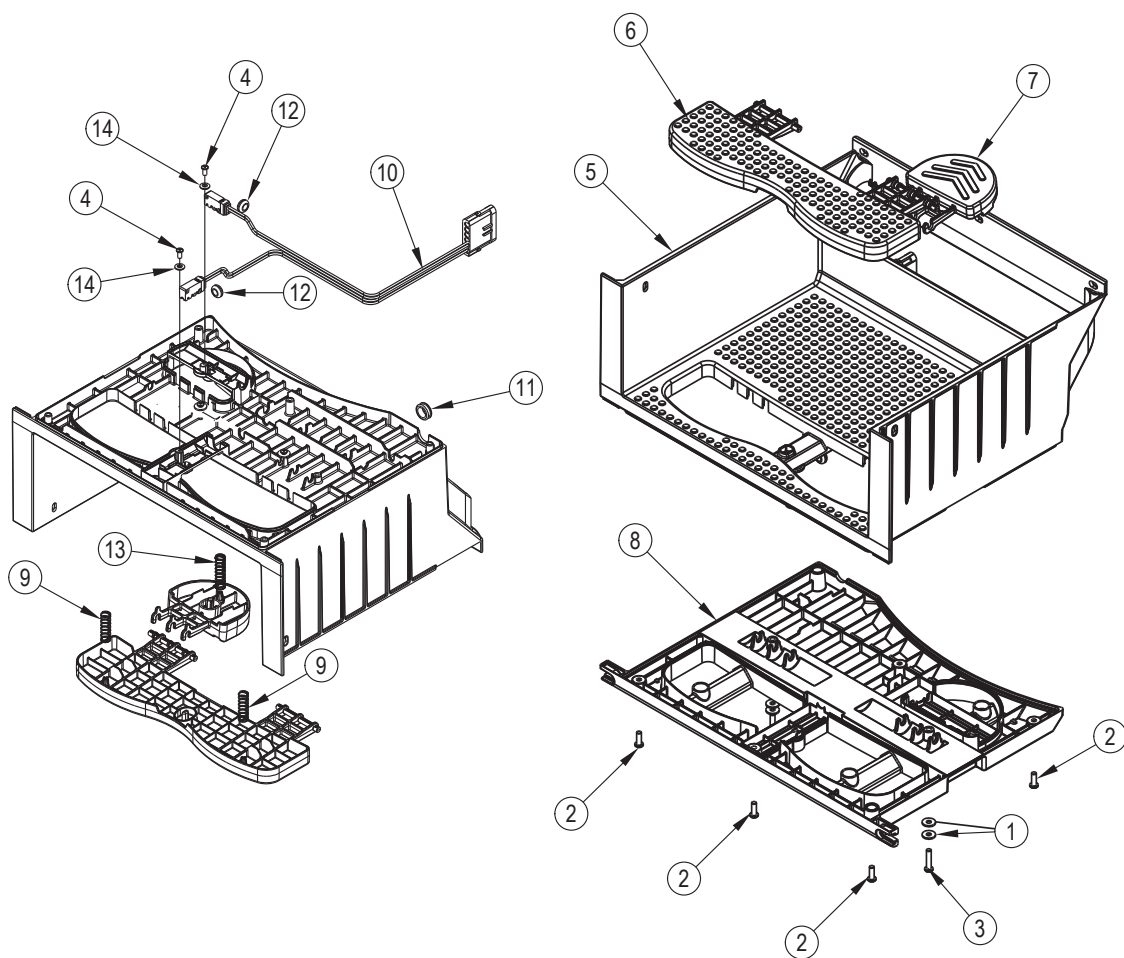

Pos.	Product no	QTY	Description	Notes
0		1	PLATFORM ASSEMBLY	
1		4	WASHER	[1]
2		6	Scr-Pan Phil Plast M6x2.5x16mm	[2]
3		2	Scr-Pan Phil Plast M6x2.5x20mm	[2]
4		4	Scr-Pan Phil Plast M5x2.3x10mm	[2]
5	56104052	1	PLATFORM-UPPER	
6	56104185	1	PEDAL-SAFETY	
7	56384567	1	PEDAL-FOOT	[3]
8	56104187	1	PLATFORM-BOTTOM	
9	56384579	3	SPRING-COMPRESSION-M/W-.480 OD	[4]
10	56104406	1	SWITCH HARNESS	
11	56158690	1	GROMMET .687 E00059	
12	56331006	2	GROMMET E00059	
13	56384568	1	SPRING-COMPRESSION-SS-.480 OD	[5]
14		1	Washer	[2]
			SERVICE KITS	
K1	56104417	1	PLATFORM HARDWARE KIT	[6]

Part Notes:

- [1] - All machines built prior to SN3510144706623 order and install Neoprene Washer PN 56209261. Note that the Neoprene Washer has been replaced by Washer, part number 1451261000.
 TSB-FC-2014-043 SC1500 Safety Pedal Switch

- [2] - K1
- [3] - TSB-FC-2016-265 SC1500 Foot pedal redesign
 DE TSB-FC-2016-265 SC1500 Fusspedal neu konstruiert
- [4] - To replace a spring on machines built before July 2015, order (2) of 56384579 and (1) of 56384568. All three springs should be replaced at the same time for these machines.
 TSB-FC-2016-265 SC1500 Foot pedal redesign
 DE TSB-FC-2016-265 SC1500 Fusspedal neu konstruiert
- [5] - To replace a spring on machines built before July 2015, order (2) of 56384579 and (1) of 56384568. All three springs should be replaced at the same time for these machines.
 TSB-FC-2016-265 SC1500 Foot pedal redesign
 DE TSB-FC-2016-265 SC1500 Fusspedal neu konstruiert
- [6] - Includes Pos. 1, 2, 3, 4, 14

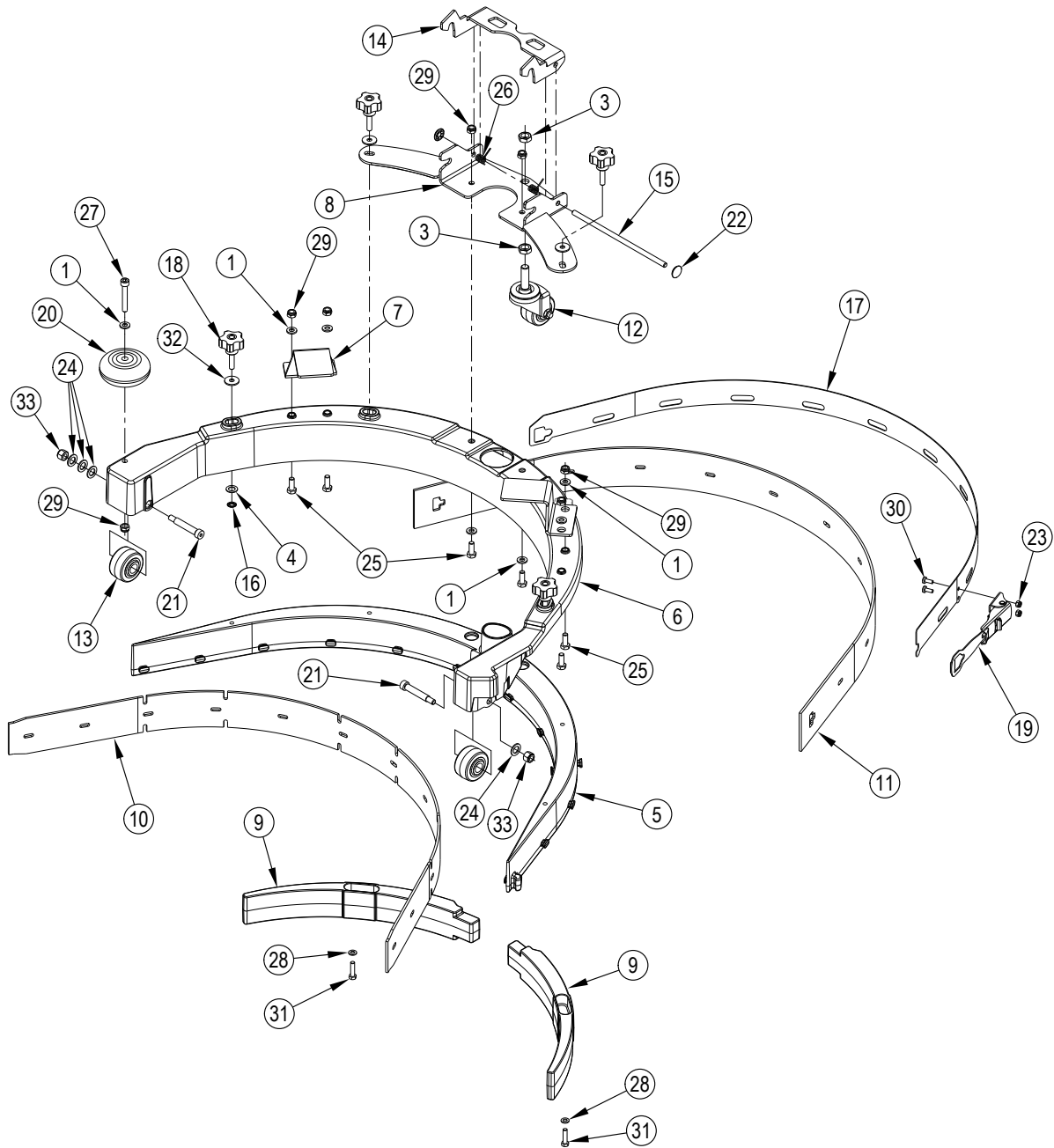

Pos.	Product no	QTY	Description	Notes
1		7	K3,K4,K6 - Washer, Flat 6,4X12,5 S.S.	
3		2	K4,K6 - Nut-Hex Jam Ss 3/8-16	
4		4	K4,K5 - Wsh-Flt .328 X .563 X .031	
5	56104141	1	SQUEEGEE CASTINGK4 -	[1]
6	56104142	1	SQUEEGEE COVERK4 -	[2]
7		2	K4 - Squeegee Lift Bracket	
8		1	K4,K8 - Squeegee Bracket Weldment	
9		2	K4 - Squeegee Plate	
10		1	K2,K4 - Blade-Squeegee Linatex Front	[3]
		1	K1 - Blade-Squeegee Pu Front	[4]
11		1	K2,K4 - Blade-Squeegee Linatex Rear	[3]
		1	K1 - Blade-Squeegee Pu Rear	[4]
12	56104231	1	CASTER WHEELK4,K6 -	[5]
13		2	K4,K6 - Roller Wheel	
14		1	K4,K8 - Squeegee Mount Brkt	
15		1	K4,K8 - Pivot Pin	
16		4	K4,K5 - Retaining Ring	
17		1	K4,K7 - Strap-Squeegee Rear	
18		4	K4,K5 - Knob	
19		1	K4,K7 - Latch-T Tab Assy	
20		1	K4,K6 - Wheel	
21		2	K4,K6 - Pin-Clevis .312 X 1.78	
22		2	K4,K8 - Pin Cover-6mm	
23		2	K4,K7 - Nut, Hex Nyl Loc Thin M4 Ss	
24		3	K4,K6 - Washer 8x24x2 Uni 6593 Ss	
25		6	K3,K4 - Screw, Hex Thd To Hd M6x16 Ss	
26		2	K4,K8 - Spring Acc. Lid Lh	
27		1	K4,K6 - Screw Soc. Hd M6X45	
28		2	K3,K4 - Washer, Flat 5.3X10X1 Ss	
29		7	K3,K4,K6 - Nut, Hex Nyl Loc Thin M6 Ss	
30		2	K4,K7 - Scr, Pan Phil M4x10 Ss	
31		2	K3,K4 - Screw, Hex Thd To Hd M5x20 SS	
32	L08603689	4	WASHER PLAIN M6X18 SS ISO7093K4,K5	
			SERVICE KITS	
K1	56104325	1	SQUEEGEE KIT-BLADE-PU	[6]
K2	56104483	1	SQUEEGEE KIT-BLADE-LINATEX	[6]
K3	56104327	1	SQUEEGEE HARDWARE KIT	[7]
K4	56104378	1	SQUEEGEE ASSY KIT	[8]
K5	56104429	1	SQUEEGEE KNOBS KIT	[9]
K6	56104385	1	SQUEEGEE WHEELS KIT	[10]
K7	56104386	1	SQUEEGEE STRAP KIT	[11]
K8	56104387	1	SQUEEGEE MOUNT BRKT KIT	[12]

Part Notes:

- [1] - The squeegee casting and cover are available for sale separately. If you need to replace the whole assembly, please order the Squeegee Assy Kit 56104378
- [2] - EXPIRED USE 56104989
The squeegee casting and cover are available for sale separately. If you need to replace the whole assembly, please order the Squeegee Assy Kit 56104378
- [3] - All squeegee blade kits include both front and rear squeegee blades
- [4] - All squeegee blade kits include both front and rear squeegee blades. Optional, Not Included
- [5] - K4,K6TSB-FC-2015-024 SC1500 Poor water pick-up while scrubbing
- [6] - Including pos. 10,11
- [7] - Including pos. 1,28,29,31
- [8] - Including pos. 1-32
- [9] - Including pos. 4,16,18,32
- [10] - Including pos. 1,2,3,12,13,20,21,24,27,29
TSB-FC-2017-025 SC1500 SA40 Squeegee roller wheels
DE TSB-FC-2017-025 SC1500 Saugfuss Laufrollen
- [11] - Including pos. 17,19,23,30

[12] - Including pos. 8,14,15,22,26

TSB-FC-2016-268 SC1500 Squeegee Streaking

DE TSB-FC-2016-268 SC1500 Streifenbildung durch den Saugfuss

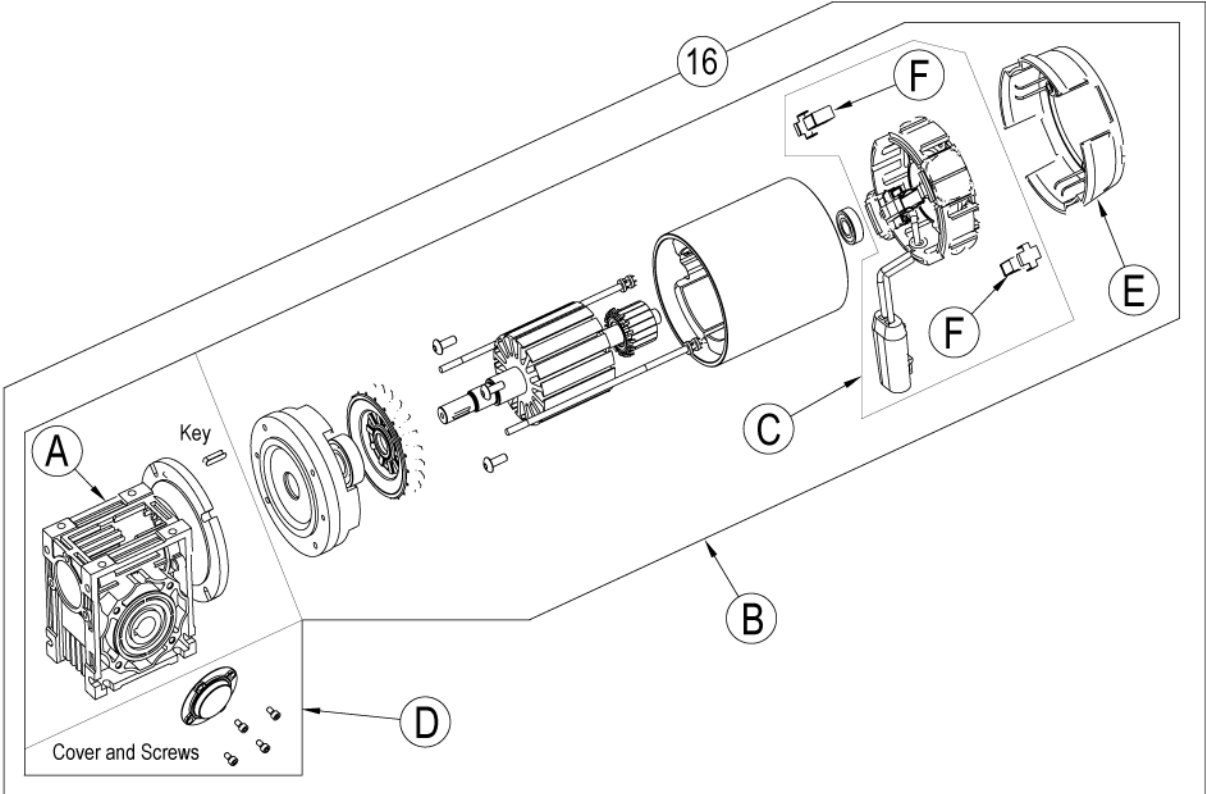

Pos.	Product no	QTY	Description	Notes
A	56104297	1	MOTOVARIO GEARBOX 15/1	
B	56104298	1	MOTOR	
C	56104300	1	BRUSH HOUSING ASSEMBLY	
D	56601588	1	COVER AND SCREWS	
E	56601508	1	PLASTIC COVER	
F	56601534	1	CARBON BRUSH	
16	56104071	1	DISC BRUSH MOTOR	

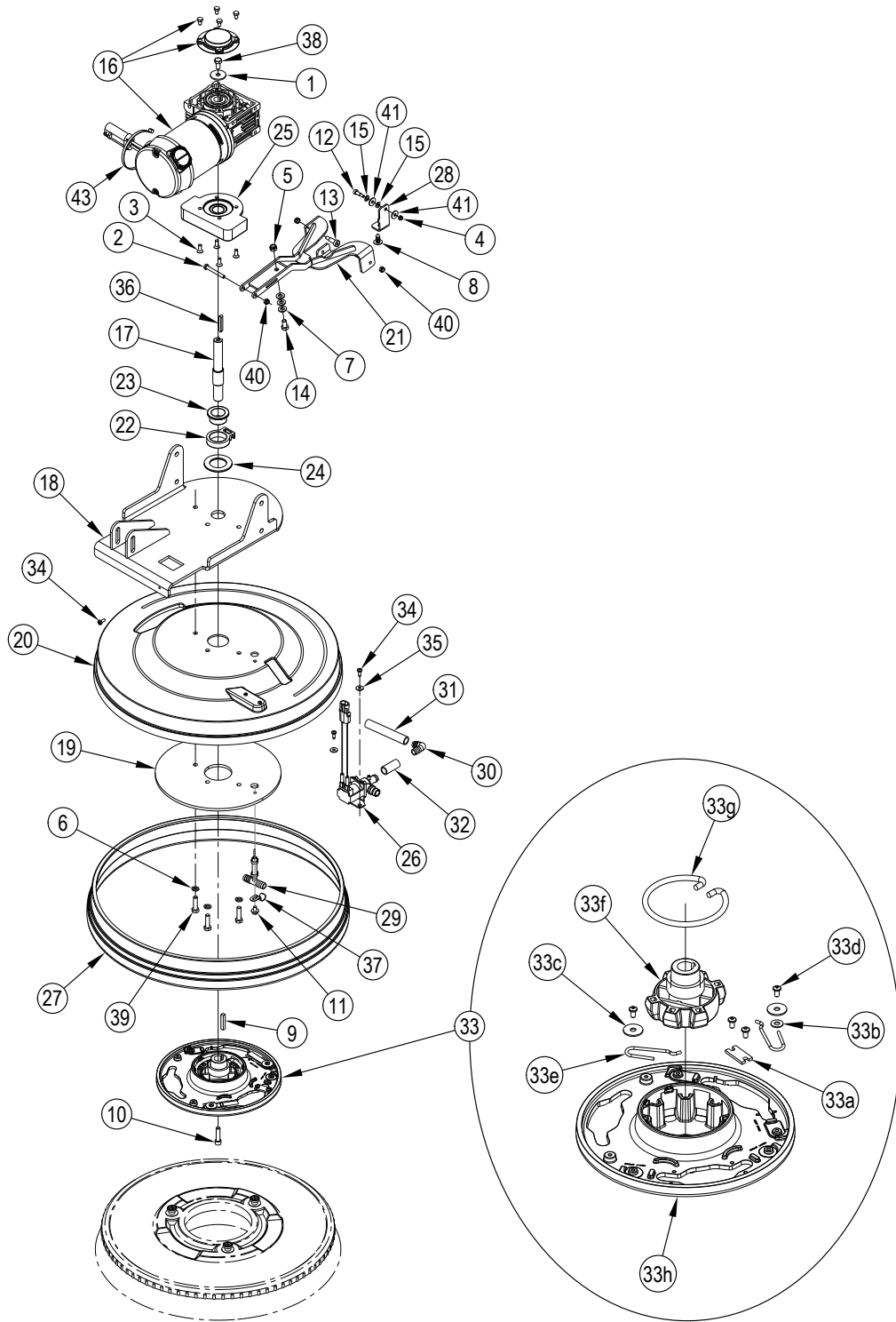

Pos.	Product no	QTY	Description	Notes
1		1	Washer 8x32x2.5uni6593 10 Pcs	[1]
2		1	SCREW, HEX THD TO HD M6X50	[1]
3		4	SCREW, FLAT SOCKET HEAD	[1]
4		1	NUT, HEX NYL LOC THIN M5	[1]
5		1	NUT, HEX NYL LOC THIN M8	[1]
6		3	Washer M8 Uni1751b 10 Pcs Set	[1]
7		1	WASHER, FLAT 8.4X16X1.6	[1]
8		1	RIVET, NYLON TREE PUSH-IN (.25)	[1]
9		1	KEY, SQUARE .25 X 1.44	[1]
10		1	SCR-SOC HD 5/16-18 X 1.25 ZINC	[1]
11		1	SCR-HEX THD FORM M6 X 10MM	[1]
12		1	SCR-SOC SHD M6X12MM X M5-0.8	[1]
13		2	SCR-SOC SHD M8X16MM X M6-1.00	[1]
14	56003890	1	SCR-HEX PLASTIC M8-1.25X16MM	[1]
15		2	WSH, BOWED .266X.500X.060	[1]
16	56104071	1	DISC BRUSH MOTOR	
17	56104095	1	SHAFT DISC BRUSH MOTOR	
18	56104117	1	DECK LIFT PLATE WELDMENT	
19	56104120	1	LOWER DECK PLATE	
20	56104121	1	BRUSH HOUSING	
21	56104126	1	SQUEEGEE LINK WELDMENT	
22		1	SQUEEGEE PIVOT BLOCK	[2]
23		1	BEARING FLANGE	[2]
24		1	SQUEEGEE PIVOT WASHER	[2]
25	56104137	1	SPACER MOTOR	
26	56104169	1	SOLENOID VALVE ASSY	
27	56104240	1	SKIRT BRUSH	
28	56104241	1	DOUBLE SCRUB BRKT	
29	56314983	1	TEE ASSEMBLY	
30	56386183	1	HOSE BARB 90 DEG	
31	56397209	1	HOSE PVC .500X4.0 E00199	
32	56397217	1	HOSE PVC .500X1.50 E00199	
33	56601733	1	BRUSH PLATE ASSY-CCW	
33a	56366455	1	PLATE CV24B	
33b		1	WSH, FLT STD 10	[1]
33c		2	WSH, FLT .266 X .906 X .060	[1]
33d		4	SCR, PAN PHIL PLASTITE 10-14 X .38	[1]
33e	56109653	2	SPRING RETAINER	
33f	56112521	1	GIMBAL-COLLAR ASSEMBLY	
33g	56601056	1	SPRING BRUSH HOLDER	
33h	56601118	1	BRUSH PLATE	
34		3	SCR, PAN HD THD FORM	[1]
35		2	WASHER, FLAT XL 5,5X15X1,2 SS	[1]
36		1	KEY	[1]
37	909 5483 000	1	CLAMP D.16	
38		1	SCREW, HEX THD TO HD M8X16 LOCTITE	[1]
39		3	SCREW, HEX THD TO HD M8X30 SS	[1]
40		3	NUT, HEX NYL LOC THIN M6 SS	[1]
41		2	Washer, Flat XI Ss	[1]
42		1	Screw Cyl Hd M5x12	
43	1450524000	1	CLAMP	
K1	56104344	1	SQUEEGEE PIVOT KIT	[3]
K2	56104346	1	DISC DECK HARDWARE KIT	[4]

Part Notes:

- [1] - K2
- [2] - K1
- [3] - Includes pos. 22-24
- [4] - Includes pos. 1-15,33b-c-d,34-36,38-41

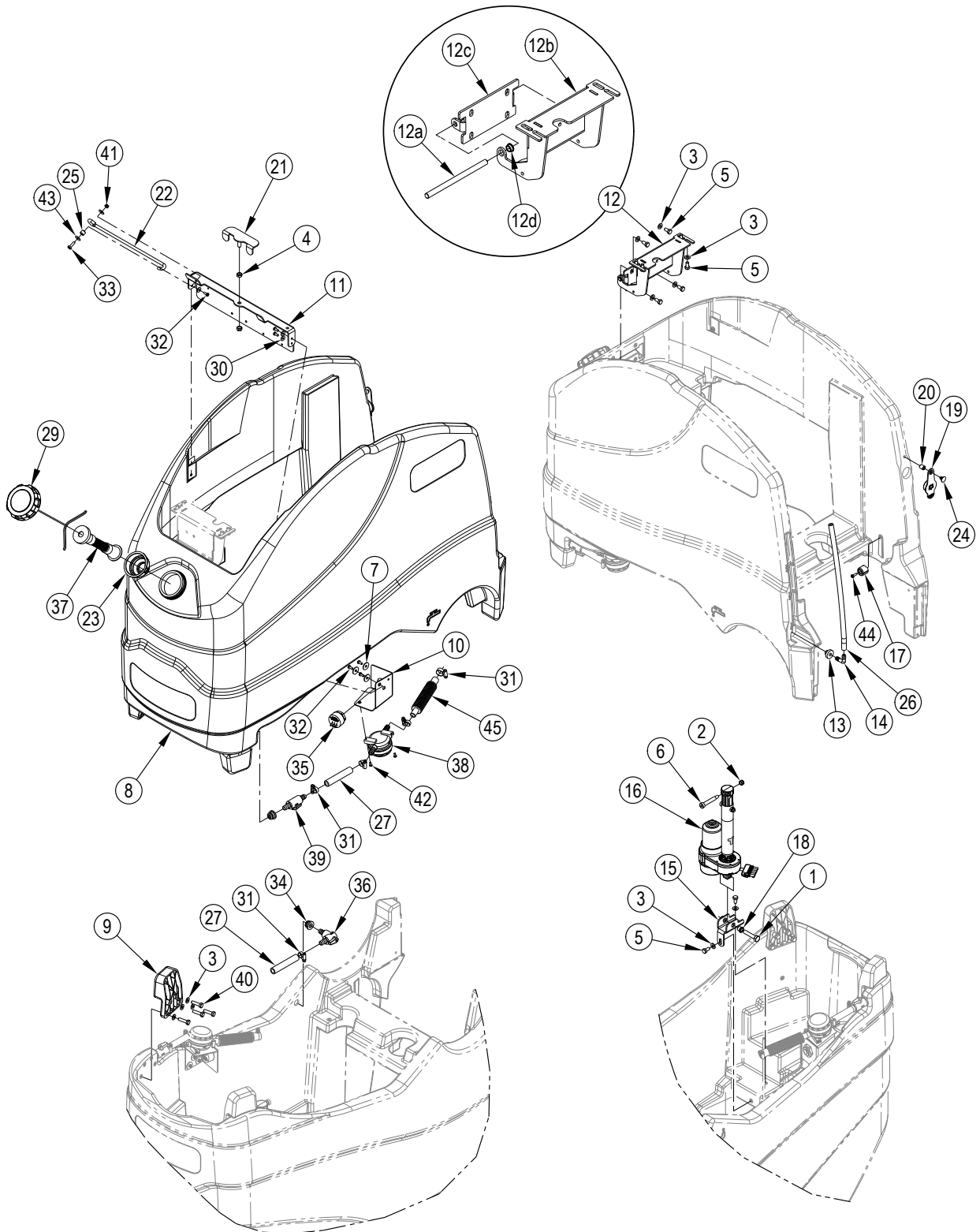

Pos.	Product no	QTY	Description	Notes
1		1	SCREW, HEX THD TO HD M10X50	[1]
2		1	NUT, HEX NYL LOC THIN M8	[1]
3		18	WASHER, FLAT 8.4X16X1.6	[2]
4		2	NUT, HEX NYL LOC-THIN SS 3/8-16	[3]
5		10	SCR-HEX M8-1.25 X 16MM	[3]
6		1	SCR-SOC SHD M10X50MM X M8-1.25	[1]
7		3	WSH, FLT .266 X .906 X .060	[3]
8	56104050	1	SOLUTION TANK	
9		2	TIP PAD	[4]
10	56104165	1	FILTER BRACKET	
11	56104445	1	BRACKET-TANK SUPPORT	
12	56104209	1	HINGE ASSEMBLY	
12a	56104206	1	HINGE PIN	
12b	56104207	1	HINGE WELDMENT	
12c	56104208	1	HINGE BRACKET	
12d	56104249	2	BEARING FLANGE	
13	56104229	1	GROMMET	
14	51526A	1	HOSEBARB 3/8 X 90 DEG	
15	56104234	1	ACTUATOR BRKT	
16		1	ACTUATOR ASSEMBLY (M3)	[5]
17	56104308	2	PIVOT BLOCK	
18		1	SPACER ACTUATOR	[6]
19		1	RUBBER SOLUTION CAP	[7]
20	56104390	1	INSERT-BRASS M8	
21	56104391	1	ADJUSTMENT PAD	
22	56104409	1	PROP ROD	
23		1	FILL HOSE SUPPORT	[8]
24		1	CLIP, PANEL	[7]
25		1	BUSHING	[3]
26	56393382	1	HOSE E00552	[9]
27		2	HOSE, SPIRAL .500	[10]
29	56510442	1	CAP-EXTRA VENT	
30		3	WASHER, FLAT XL 5,5X15X1,2 SS	
31		5	Clamp, Hose	[10]
32		6	SCR, PAN PHIL M5X12 SS	[3]
33		1	Screw	[3]
34		2	GASKET	[10]
35	909 6126 000	1	BUZZER 3-28V DC	
36		1	BALL VALVE 90°	[11]
37		1	FILLING HOSE	[8]
38		1	FILTER, WATER	[12]
39		1	BALL VALVE	[13]
40		8	SCREW, HEX THD TO HD M8X30 SS - TSB-FC-2013-127	[2]
41		1	NUT, HEX NYL LOC THIN M6 SS	[3]
42		2	SCR, PAN PHIL M4X10 SS	[14]
43		1	WASHER, FLAT XL SS	[3]
44		2	SCR,PAN PHIL M5X16 SS	[3]
45		1	HOSE, SOLUTION	[13]
46		1	SERVICE KITS	
K1	56104349	1	SOLUTION DRAIN KIT	[15]
K2	56104350	1	SOLUTION HOSE KIT	[16]
K3	56104351	1	SOLUTION FILTER KIT	[17]
K4	56104354	1	SOLUTION CAP KIT	[18]
K5	56104356	1	ACTUATOR KIT	[19]
K6	56104357	1	TIP PAD KIT	[20]
K7	56104358	1	SOLUTION HARDWARE KIT	[21]
K8	56112355	1	KIT-REFILLING HOSE	[22]

Part Notes:

- [1] - K5,K7
- [2] - K6,K7
- [3] - K7
- [4] - K6
- [5] - K5
TSB-FC-2016-271 SC1500 Poor water pick-up Vacuum Only Mode
- [6] - K5
- [7] - K4
- [8] - K8
- [9] - Expired 10/11/2006
- [10] - K1,K2
- [11] - K1
- [12] - K3
TSBFC 2013-127 SC400 450 800 1500 BA 651 SR 1601 Sc 343_2 Sc 8 Frischwasserfilter
- [13] - K2
- [14] - K3,K7
- [15] - Includes pos. 27,31,36
- [16] - Includes pos. 27,31,34,39,45
- [17] - Includes pos. 38,42
- [18] - Includes pos. 19,24
- [19] - Includes pos. 1,2,6,16,18
- [20] - Includes pos. 3,9
- [21] - Includes pos. 1-7,25,30,32,33,40-44
- [22] - Includes pos. 9,23,37

SQUEEGEE BLADE SELECTOR GUIDE

Red Gum Rubber: Provides longest life on finished or unfinished concrete floors.

Polyurethane: Oil resistance provides superior life in applications with oily floors.

SQUEEGEE BLADE APPLICATION GUIDE(SUGGESTION ONLY)		
Performance Traits	Red Gum Rubber (Natural Rubber)	Polyurethane/ Pentathane
Resilience		X
Tear Strength		X
Abrasion Resistance	X	X
Wear Resistance	X	X
Low Temp Flexibility	X	
High Temp Flexibility		X
Ozone Resistance		
Chemical Resistance		X
Applications		
Oil Resistant Applications		X
General Purpose	X	X
Hot Water Applications	X	X
Chemical Applications		X
Color	Red	Translucent

OPTIONAL KITS AND ACCESSORIES

SC1500 51D NIL

2017.11.02

2019.01.30

Pos.	Product no	QTY	Description	Notes
			Kits	
	56104403	1	ON BOARD CHARGER-EU KIT	
	56104437	1	SHELF CHARGER ADAPTER KIT	[1]
	56384204	1	USER INTERFACE KIT	
	56104372	1	INTERFACE PANEL KIT	
	56394063	1	RECOVERY TANK KIT	[2]
			Squeegee Blade Kits (See Squeegee Blade Selector Guide)	
	56104325	1	SQUEEGEE KIT-BLADE-PU	[3]
	56104483	1	SQUEEGEE KIT-BLADE-LINATEX	[3]
			Accessories	
	56397453	1	INDICATOR BATTERY LEVEL	[4]
	56383571	1	PROGRAMMER-USER	
	56383572	1	PROGRAMMER CABLE-MOLEX	
	56104192	1	EU CHEMICAL INJECTION KIT	
	56104190	1	ECOFLEX BOTTLE ASSY	
	56044629	1	LITERATURE PACK	[5]
			20" Disk Scrub Brushes (See Brush Selector Guide)	
	56505790	1	PAD HOLDER-20 3 LUG	
	56505791	1	DISC BRUSH-20 MAGNAGRIT 3 LUG	
	56505792	1	DISC BRUSH-20 DYNA GRIT 3 LUG	
	56505793	1	DISC BRUSH-20 AGLITE 3 LUG	
	56505794	1	DISC BRUSH-20 PROLENE 3 LUG	
	56505795	1	DISC BRUSH-20 PROLITE 3 LUG	
	56505796	1	DISC BRUSH-20 UNION MIX 3 LUG	
	56505797	1	DISC BRUSH-20 MIDGRIT 3 LUG	
	56505798	1	DISC BRUSH-20 MIDLITE 3 LUG	
	10001955	1	PAD 20 508MM ECO BLACK 5PCS	
	10001957	1	PAD 20 508MM ECO BROWN 5PCS	
	976069	1	PAD-GREEN-20-5/CS	
			REV Pads (See Pad Selector Guide)	
	56390045	1	VELCRO 2 SIDED 20	
	56390046	1	PAD-MAROON-20-10/CS	[6]
	56384451	1	PAD-MAROON-20-10/CS	
	56390079	1	PAD MICRO FIBER	
	10001959	1	PAD 20 508MM ECO RED 5PCS	
	10001960	1	PAD 20 508MM ECO WHITE 5PCS	

Part Notes:

- [1] - ONLY USED IN US
- [2] - TSB-FC-2018-008 SC1500 Recovery Tank Cracking
- [3] - All squeegee blade kits include both front and rear squeegee blades.
- [4] - NOT FOR SALE VIA EDC
- [5] - PRINT FROM HOMEPAGE
- [6] - COMPLEXITY REDUCTION

BRUSH SELECTOR GUIDE

We provide brushes and pad holders that will give you the best possible performance between machine and floor. Following are descriptions of the materials and their applications.

- Soft Nylon:** Bristles are made from light-duty polypropylene for general scrubbing when you do not want to scratch or remove finish from the floor. Recommended for use in place of red pads.
- Poly:** Polypropylene material for medium-duty scrubbing on concrete, terrazzo and vinyl floor tile. Recommended for use in place of green or blue pads.
- Lite Grit:** For light scrubbing when used wet; buffing or polishing when used dry on urethane coated, sealed concrete or other resilient hard surface floors. Recommended for use in place of red or white pads.
- Medium Grit:** For general purpose scrubbing of sealed or unsealed concrete, stone, terrazzo, quarry tile and other resilient hard floor surfaces. Recommended for use in place of green or blue pads.
- Heavy Grit:** For aggressive, heavy-duty scrubbing or stripping of floors. Recommended for use in place of brown pads.

20" Disk Scrub Brushes

- 56505790 - Pad Holder
- 56505791 - Magnagrit
- 56505792 - Dyna Grit
- 56505793 - Aglite
- 56505794 - Prolene
- 56505795 - Prolite
- 56505796 - Union Mix
- 56505797 - Midgrit
- 56505798 - Midlite
- 976170 - Pads Cs 20 Black Thin (Qty 5)
- 976070 - Pads Cs 20 Brown 51 (Qty 5)
- 976069 - Pads Cs 20 Blue 51 (Qty 5)

DISC BRUSH APPLICATION GUIDE (SUGGESTION ONLY)

Application	Heavy Grit	Medium Grit	Lite Grit	Poly	Soft Nylon
Stripping:					
Concrete	X				
Terrazzo	X				
Ceramic/Quarry tile	X				
Vinyl tile	X				
General Scrubbing:					
Concrete	X	X	X	X	
Terrazzo		X	X	X	
Ceramic/Quarry tile		X	X	X	
Marble			X	X	X
Vinyl tile		X	X	X	
Raised-rubber tile			X	X	X

BRUSH SELECTOR GUIDE

SC1500 51D NIL

2017.11.02

2015.06.03

Pos.	Product no	QTY	Description	Notes
	10001957	1	PAD 20 508MM ECO BROWN 5PCS	
	56505790	1	PAD HOLDER-20 3 LUGPAD HOLDER-20 3 LUG	
	56505791	1	DISC BRUSH-20 MAGNAGRIT 3 LUGDISC BRUSH-20 MAGNAGRIT 3 LUG	
	56505792	1	DISC BRUSH-20 DYNA GRIT 3 LUGDISC BRUSH-20 DYNA GRIT 3 LUG	
	56505793	1	DISC BRUSH-20 AGLITE 3 LUGDISC BRUSH-20 AGLITE 3 LUG	
	56505794	1	DISC BRUSH-20 PROLENE 3 LUGDISC BRUSH-20 PROLENE 3 LUG	
	56505795	1	DISC BRUSH-20 PROLITE 3 LUGDISC BRUSH-20 PROLITE 3 LUG	
	56505796	1	DISC BRUSH-20 UNION MIX 3 LUGDISC BRUSH-20 UNION MIX 3 LUG	
	56505797	1	DISC BRUSH-20 MIDGRIT 3 LUGDISC BRUSH-20 MIDGRIT 3 LUG	
	56505798	1	DISC BRUSH-20 MIDLITE 3 LUGDISC BRUSH-20 MIDLITE 3 LUG	
	976069	1	PAD-GREEN-20-5/CS	
	10001955	1	PAD 20 508MM ECO BLACK 5PCSPADS CS 20 BLACK THIN CS/5EA	

**No
Diagram
Available**

**Parts List
Only**

RECOMMENDED SPARE PARTS

SC1500 51D NIL

2017.11.02

2019.03.18

Pos.	Product no	QTY	Description	Notes
			CHASSIS SYSTEM	
			Ordinary Maintenance	
O	56385136		HARNESS DRIVE MOTOR ASSY KIT	[1]
O	56104269		SPROCKET-11 TOOTH	
O	56104407		BEARING -FLANGE	
O	56104331		REAR WHEEL KIT	
O	56104338		KIT-WHEEL AND BEARING	
O	56104435		SPROCKET AND CHAIN KIT	
O	56104339		SPROCKET AND CHAIN KIT	
			Extra-Ordinary Maintenance	
E	56104091		MOUNTING TAB	
E	56104094		BAR-LINKAGE	
E	56104105		BATTERY TRAY	
E	56104130		STEERING SHAFT	
E	56104135		LINK BAR	
E	56104148		STEERING SHAFT WELDT	
E	56104151		SPINDLE MOUNT WELDMENT	
E	56104157		COLLAR	
E	56104448		CHASSIS WELDMENT	[2]
E	56314032		BLOCK BEARING	
E	56114378		BATTERY CHARGER 24V 25A	
E	56104328		UNIVERSAL JOINT KIT	
E	56104332		BEARING BLOCK KIT	
E	56104333		CHASSIS HARDWARE KIT	
E	56104336		DRIVE WHEEL MOTOR KIT	
E	56104340		DRIVE WHEEL HARDWARE KIT	
E	56104384		FRONT WHEEL BEARINGS KIT	
			CONTROL SYSTEM	
			Normal Wear	
W	56104270		CHAIN-ROLLER	
			Extra-Ordinary Maintenance	
E	56104053		CONTROL PANEL	
E	56104196		SHAFT STEERING	
E	56104265		SHAFT HEX	
E	56104410		BRACKET-PROP ROD	
E	56601060		STEERING WHEEL	
E	56104498		DRIVE WELDMENT KIT	
E	56104077		SPINDLE WELDT	
E	56104115		STEERING PLATE	
E	56104328		UNIVERSAL JOINT KIT	
E	56104352		DRAW LATCH KIT	
E	56104365		CONTROL HARDWARE KIT	
			ELECTRICAL SYSTEM	
			Extra-Ordinary Maintenance	
E	56104423		CIRCUIT BREAKER-50 AMP	
E	56104444		HARNESS-MAIN	
E	56104176		SOLID STATE RELAY	
E	56104193		ELECTRICAL PANEL	
E	56104243		SPEED CONTROLLER	
E	56104247		DISCONNECT-EMERGENCY	
E	56104281		CABLE-POWER	
E	56112354		HANDLE	
E	56315255		CIRCUIT BREAKER 5 AMP	
E	56409485		CABLE ASSY.1 X 15.00	
E	56412089		FUSE 150 AMP	
E	56413822		CIRCUIT BREAKER 20 AMP	
E	56469858		ELECTRICAL MOUNT	
E	56509623		CIRCUIT BREAKER-25 AMP	
E	56601172		CONNECTOR ASM	

RECOMMENDED SPARE PARTS

SC1500 51D NIL

2017.11.02

2019.03.18

Pos.	Product no	QTY	Description	Notes
E	56601183		CONTACTOR 24V 100 AMP	
E	1462888000		SWITCH KEY WITH CAP	
E	146 2887 000		KEY 2 PCS	
E	9100000882		CLAMP BATTERY POLE PLUS 2 PCS SET	
E	9100000883		CLAMP BATTERY POLE MINUS 2 PCS SET	
E	50962A		KNOB CONTROL ENCORE 2426	
E	2-00-05171		BAT TERMINAL COVER RED	
			Extra-Ordinary Maintenance	
E	2-00-05173		BAT TERMINAL COVER BLK	
E	56372673		BOOT BATTERY POST	
E	56478246		CABLE TIE E00549 RE438BA	
E	41217A		CABLE BATTERY KIT 14662B	
E	56104341		ELECTRICAL HARDWARE KIT	
E	56384204		USER INTERFACE KIT	
E	56104372		INTERFACE PANEL KIT	
			PLATFORM ASSEMBLY	
			Ordinary Maintenance	
O	56104406		SWITCH HARNESS	
			Extra-Ordinary Maintenance	
E	56104052		PLATFORM-UPPER	
E	56104185		PEDAL-SAFETY	
E	56384567		PEDAL-FOOT	
E	56104187		PLATFORM-BOTTOM	
E	56104277		COMPRESSION SPRING	
E	56158690		GROMMET .687 E00059	
E	56331006		GROMMET E00059	
E	56104417		PLATFORM HARDWARE KIT	
			RECOVERY SYSTEM	
			Ordinary Maintenance	
O	56104164		GASKET-RECOVERY TANK	
O	56104258		VAC HOSE ASSY	
O	56104285		DRAIN HOSE	
O	909 6672 000		FILTER	
			Extra-Ordinary Maintenance	
E	56104051		RECOVERY TANK	[3]
E	56104158		BACK PANEL	
E	56104306		HARNESS-JUMPER	
E	56104443		GUARD-SPLASH-4X12-POLY	
E	9100001348		CLAMP HOSE 32-52/12 10 PCS SET	
E	9096051000		VACUUM MOTOR COVER	
E	56104352		DRAW LATCH KIT	
E	56104359		KIT FLOAT CAGE	[4]
E	56104360		DEBRIS CAGE KIT	
E	56104362		HOSE CLAMP KIT	
E	56104363		VACUUM MOTOR KIT	
E	56104364		RECOVERY HARDWARE KIT	
E	56104383		VACUUM MOTOR INSULATION KIT	
			SCRUB SYSTEM-20D	
			Ordinary Maintenance	
O	909 5483 000		CLAMP D.16	
O	56601534		CARBON BRUSH	
			Extra-Ordinary Maintenance	
E	56104071		DISC BRUSH MOTOR	
E	56104095		SHAFT DISC BRUSH MOTOR	
E	56104120		LOWER DECK PLATE	
E	56104121		BRUSH HOUSING	
E	56104126		SQUEEGEE LINK WELDMENT	
E	56104137		SPACER MOTOR	
E	56104169		SOLENOID VALVE ASSY	

RECOMMENDED SPARE PARTS

SC1500 51D NIL

2017.11.02

2019.03.18

Pos.	Product no	QTY	Description	Notes
E	56104240		SKIRT BRUSH	
E	56104241		DOUBLE SCRUB BRKT	
E	56314983		TEE ASSEMBLY	
E	56386183		HOSE BARB 90 DEG	
E	56384076		HOSE-PVC-.50X3.50	
E	56397217		HOSE PVC .500X1.50 E00199	
E	56601733		BRUSH PLATE ASSY-CCW	
E	56366455		PLATE CV24B	
E	56109653		SPRING RETAINER	
E	56112521		GIMBAL-COLLAR ASSEMBLY	
E	56601056		SPRING BRUSH HOLDER	
E	56601118		BRUSH PLATE	
E	56104297		MOTOVARIO GEARBOX 15/1	
E	56104298		MOTOR	
E	56104300		BRUSH HOUSING ASSEMBLY	
E	56601588		COVER AND SCREWS	
E	56601508		PLASTIC COVER	
E	56104344		SQUEEGEE PIVOT KIT	
E	56104346		DISC DECK HARDWARE KIT	
E	56104347		DISC DECK ASSY 20 KIT	
			SCRUB SYSTEM-REV	
			Ordinary Maintenance	
O	56412287		MOTOR BRUSH/SPRING KIT	
			Extra-Ordinary Maintenance	
E	56104138		REV LIFT PLATE WELDMENT	
E	56104169		SOLENOID VALVE ASSY	
E	56104201		PLATE PIVOT	
E	56104202		HOUSING REV	
E	56104203		SQUEEGEE LINK WELDMENT	
E	56104241		DOUBLE SCRUB BRKT	
E	56104244		PLATE MOTOR	
E	56114200		CONNECTOR-ADAPTOR	
E	56390011		SHIELD SPLASH	
E	56390038		GASKET DRIVER	
E	56390044		PAD DRIVER ASSY	
E	56381532		STUD STABILIZER SHORT	
E	56390002		WEIGHT COUNTER	
E	56390021		ECCENTRIC	
E	56390027		DRIVER MOTOR	
E	56390072		MOTOR 24VDC	
E	50736A		BEARINGBALL OBS-18 6008	
E	61775A		RETAINER BEARING	
E	56104366		REV DECK ASSY KIT	[5]
E	56104367		REV DECK HARDWARE KIT	
E	56104368		REV SQUEEGEE PIVOT KIT	
E	56104369		ISOLATOR KIT	
E	56104370		SOLUTION HOSE REV KIT	
			SOLUTION SYSTEM	
			Extra-Ordinary Maintenance	
E	56104050		SOLUTION TANK	
E	56104165		FILTER BRACKET	
E	56104445		BRACKET-TANK SUPPORT	
E	56104206		HINGE PIN	
E	56104207		HINGE WELDMENT	
E	56104208		HINGE BRACKET	
E	56104249		BEARING FLANGE	
E	56104229		GROMMET	
E	51526A		HOSEBARB 3/8 X 90 DEG	
E	56104234		ACTUATOR BRKT	

RECOMMENDED SPARE PARTS

SC1500 51D NIL

2017.11.02

2019.03.18

Pos.	Product no	QTY	Description	Notes
E	56104308		PIVOT BLOCK	
E	56104390		INSERT-BRASS M8	
E	56104391		ADJUSTMENT PAD	
E	56104409		PROP ROD	
E	56393382		HOSE E00552	[6]
E	56477613		CABLE TIE E00549 RE409S+	
E	56510442		CAP-EXTRA VENT	
E	9096126000		BUZZER 5-32V	
E	56104189		INSERT-DRY BRAKE	
E	56104408		CHEMICAL BOTTLE ASSY	
E	56314942		HOSE CHEM RESISTANT	
E	56314991		HOSE CHEM RESISTANT 14	
E	56315241		PUMP CHEMICAL	
E	56383385		CORD CHARGER YELLOW US	
E	9100001817		CAP PLASTIC F DETERGENT SOLU. TANK SIP	
E	56315523		CAP DRY BREAK 1/8 BARB	
E	1466317000		SUPPORT BATTERY CHARGER CABLE KIT	
E	56104349		SOLUTION DRAIN KIT	
E	56104350		SOLUTION HOSE KIT	
E	56104351		SOLUTION FILTER KIT	
E	56104354		SOLUTION CAP KIT	
E	56104356		ACTUATOR KIT	
E	56104357		TIP PAD KIT	
E	56104358		SOLUTION HARDWARE KIT	
			SQUEEGEE SYSTEM	
			Normal Wear	
W	56104325		SQUEEGEE KIT-BLADE-PU	
W	56104483		SQUEEGEE KIT-BLADE-LINATEX	
W	56104385		SQUEEGEE WHEELS KIT	[7]
			Extra-Ordinary Maintenance	
E	56104327		SQUEEGEE HARDWARE KIT	
E	56104378		SQUEEGEE ASSY KIT	
E	56104429		SQUEEGEE KNOBS KIT	
E	56104386		SQUEEGEE STRAP KIT	
E	56104387		SQUEEGEE MOUNT BRKT KIT	
			DECAL SYSTEM	
			Extra-Ordinary Maintenance	
E	56104334		SC1500 DECAL KIT	
E	56104348		DECAL SC1500 REV KIT	
			ACCESSORY / OPTIONS	
			Extra-Ordinary Maintenance	
E	56104374		KIT SHELF CHARGER US	[4]

Part Notes:

- [1] - TSB-FC-2018-001 SC1500_SA40 Loss of Drive
- [2] - NON-SALEABLE
- [3] - EXPIRED USE 56394063
- [4] - OPEN BY MISTAKE
- [5] - SEE PI 2017-002
- [6] - Expired 10/11/2006
- [7] - TSB-FC-2017-025 SC1500 SA40 Squeegee roller wheels

**No
Diagram
Available**

**Parts List
Only**

RECOMMENDED SPARE PARTS CONTINUED

SC1500 51D NIL

2017.11.02

2019.03.25

Pos.	Product no	QTY	Description	Notes
			SCRUB SYSTEM-20D CONTINUED	
			Ordinary Maintenance	
O	56601534		CARBON BRUSH	
			Extra-Ordinary Maintenance	
			Plastic Cover	
E	56601508		PLASTIC COVER	
E	56104344		SQUEEGEE PIVOT KIT	
E	56104346		DISC DECK HARDWARE KIT	
E	56104347		DISC DECK ASSY 20 KIT	
			Extra-Ordinary Maintenance	
E	56104050		SOLUTION TANK	
E	56104165		FILTER BRACKET	
E	56104445		BRACKET-TANK SUPPORT	
E	56104209		HINGE ASSEMBLY	
E	56104206		HINGE PIN	
E	56104207		HINGE WELDMENT	
E	56104208		HINGE BRACKET	
E	56104249		BEARING FLANGE	
E	56104229		GROMMET	
E	51526A		HOSEBARB 3/8 X 90 DEG	
E	56104234		ACTUATOR BRKT	
E	56104308		PIVOT BLOCK	
E	56104390		INSERT-BRASS M8	
E	56104391		ADJUSTMENT PAD	
E	56104409		PROP ROD	
E	56393382		HOSE E00552	[1]
E	56477613		CABLE TIE E00549 RE409S+	
E	56510442		CAP-EXTRA VENT	
E	909 6126 000		BUZZER 3-28V DC	
E	56104189		INSERT-DRY BRAKE	
E	56104408		CHEMICAL BOTTLE ASSY	
E	56314942		HOSE CHEM RESISTANT	
E	56314991		HOSE CHEM RESISTANT 14	
E	56315241		PUMP CHEMICAL	
E	9100001817		CAP PLASTIC F DETERGENT SOLU. TANK SIP	
E	56315523		CAP DRY BREAK 1/8 BARB	
E	1466317000		SUPPORT BATTERY CHARGER CABLE KIT	
E	56104349		SOLUTION DRAIN KIT	
E	56104350		SOLUTION HOSE KIT	
E	56104351		SOLUTION FILTER KIT	
E	56104354		SOLUTION CAP KIT	
E	56104356		ACTUATOR KIT	
E	56104357		TIP PAD KIT	
E	56104358		SOLUTION HARDWARE KIT	
			SQUEEGEE SYSTEM	
			Normal Wear	
W	56104325		SQUEEGEE KIT-BLADE-PU	
W	56104483		SQUEEGEE KIT-BLADE-LINATEX	
W	56104385		SQUEEGEE WHEELS KIT	
			Extra-Ordinary Maintenance	
E	56104327		SQUEEGEE HARDWARE KIT	
E	56104378		SQUEEGEE ASSY KIT	
E	56104429		SQUEEGEE KNOBS KIT	
E	56104386		SQUEEGEE STRAP KIT	
E	56104387		SQUEEGEE MOUNT BRKT KIT	
			DECAL SYSTEM - SC1500	
			Extra-Ordinary Maintenance	
E	56104335		SC1500 EU DECAL KIT	
E	56104481		SC1500 EU ECOFLEX DECAL KIT	

RECOMMENDED SPARE PARTS CONTINUED

SC1500 51D NIL

2017.11.02

2019.03.25

Pos.	Product no	QTY	Description	Notes
			ACCESSORY / OPTIONS	
			Extra-Ordinary Maintenance	
E	56104192		EU CHEMICAL INJECTION KIT	
E	56104403		ON BOARD CHARGER-EU KIT	

Part Notes:

[1] - Expired 10/11/2006

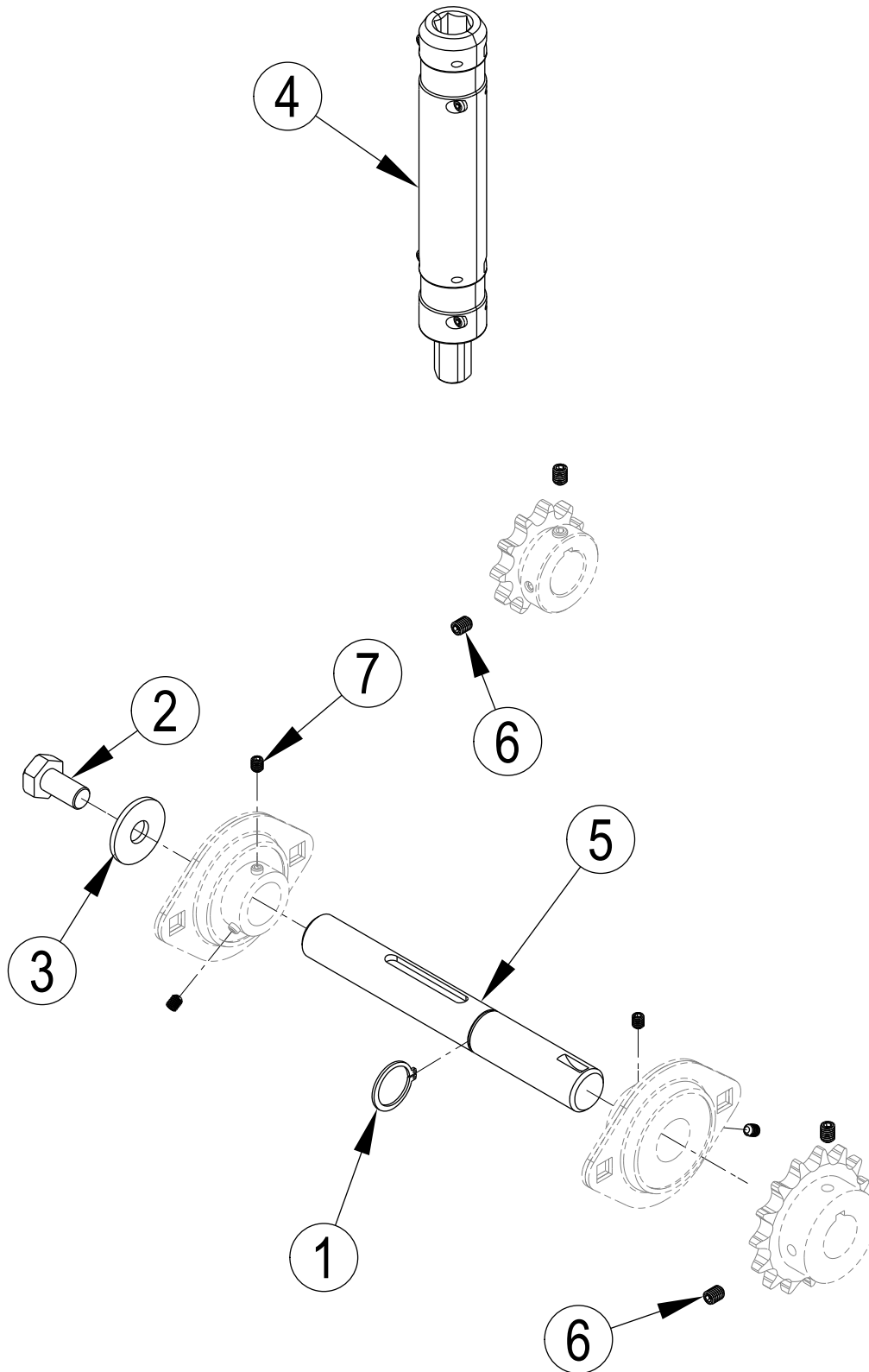

56104441 DRIVE WHEEL MOUNTING KIT

SC1500 51D NIL

2017.11.02

2018.01.24

Pos.	Product no	QTY	Description	Notes
0	56104441	1	DRIVE AXLE MOUNTING KIT	
1	9100001346	1	RING D 20 UNI7435 10 PCS SET	
2	56003533	1	SCR HEX SS M10-1.50X20MM	
3	56003959	1	WSH-FLT A2 DIN9021 10.5X30X2.5	
4	56104319	1	TUBE-STEERING ASSEMBLY	
5	56104420	1	AXLE	
6	56104436	4	SOC SET LOC M6 X 1MM X 8MM	
7	56104440	4		

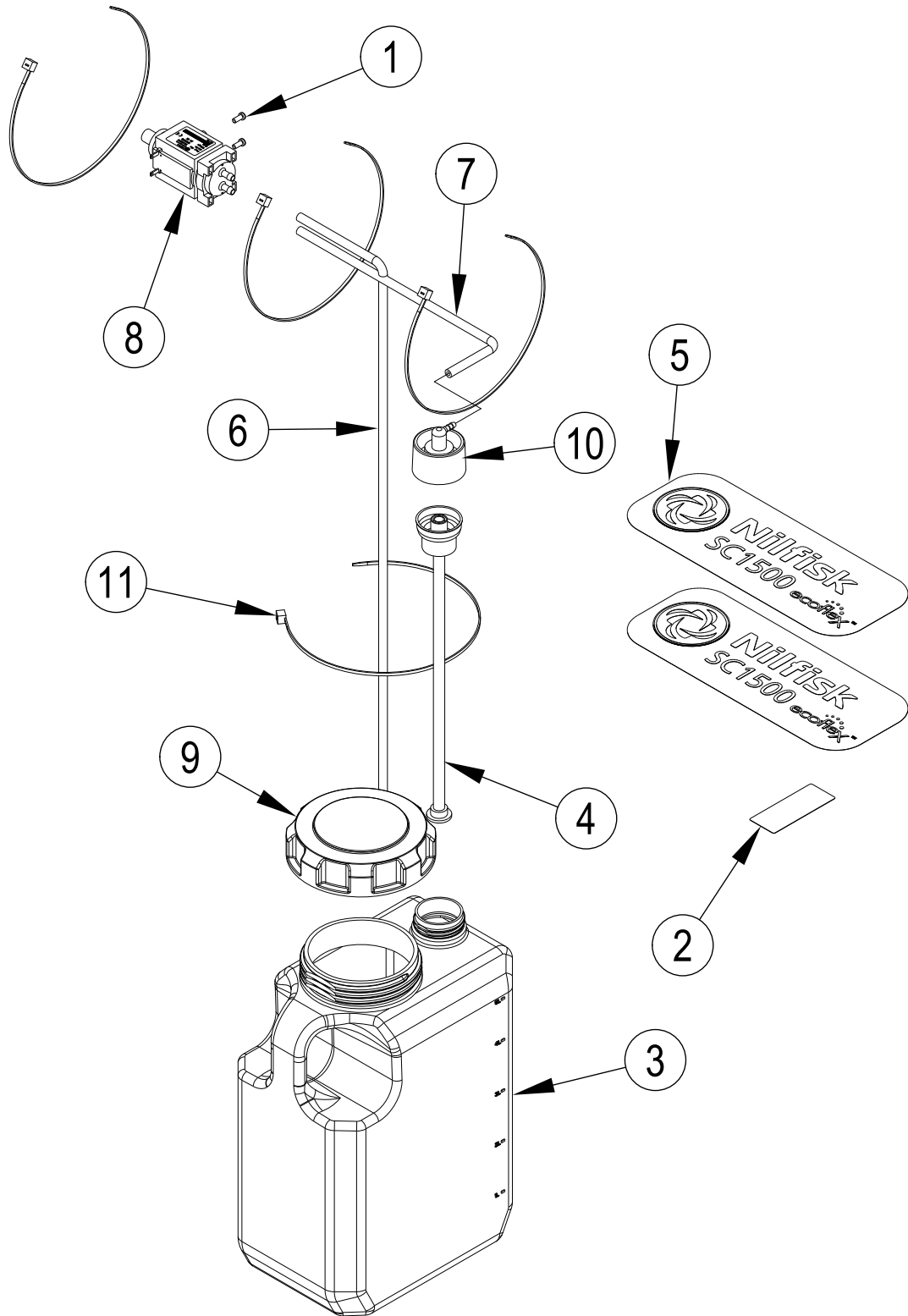

Pos.	Product no	QTY	Description	Notes
0	56104192	1	EU CHEMICAL INJECTION KIT	
1	56003970	2		
2	56016331	1	DECAL CHEMICAL RATIO	
3	56104177	1		
4	56104189	1	INSERT-DRY BRAKE	
5	56104311	2		
6	56314942	1	HOSE CHEM RESISTANT	
7	56314991	1	HOSE CHEM RESISTANT 14	
8	56315241	1	PUMP CHEMICAL	
9	9100001817	1	CAP PLASTIC F DETERGENT SOLU. TANK SIP	
10	56315523	1	CAP DRY BREAK 1/8 BARB	
11	1466337000	1	TIE CABLE 4.8X430 WHITE 2 PCS SET	

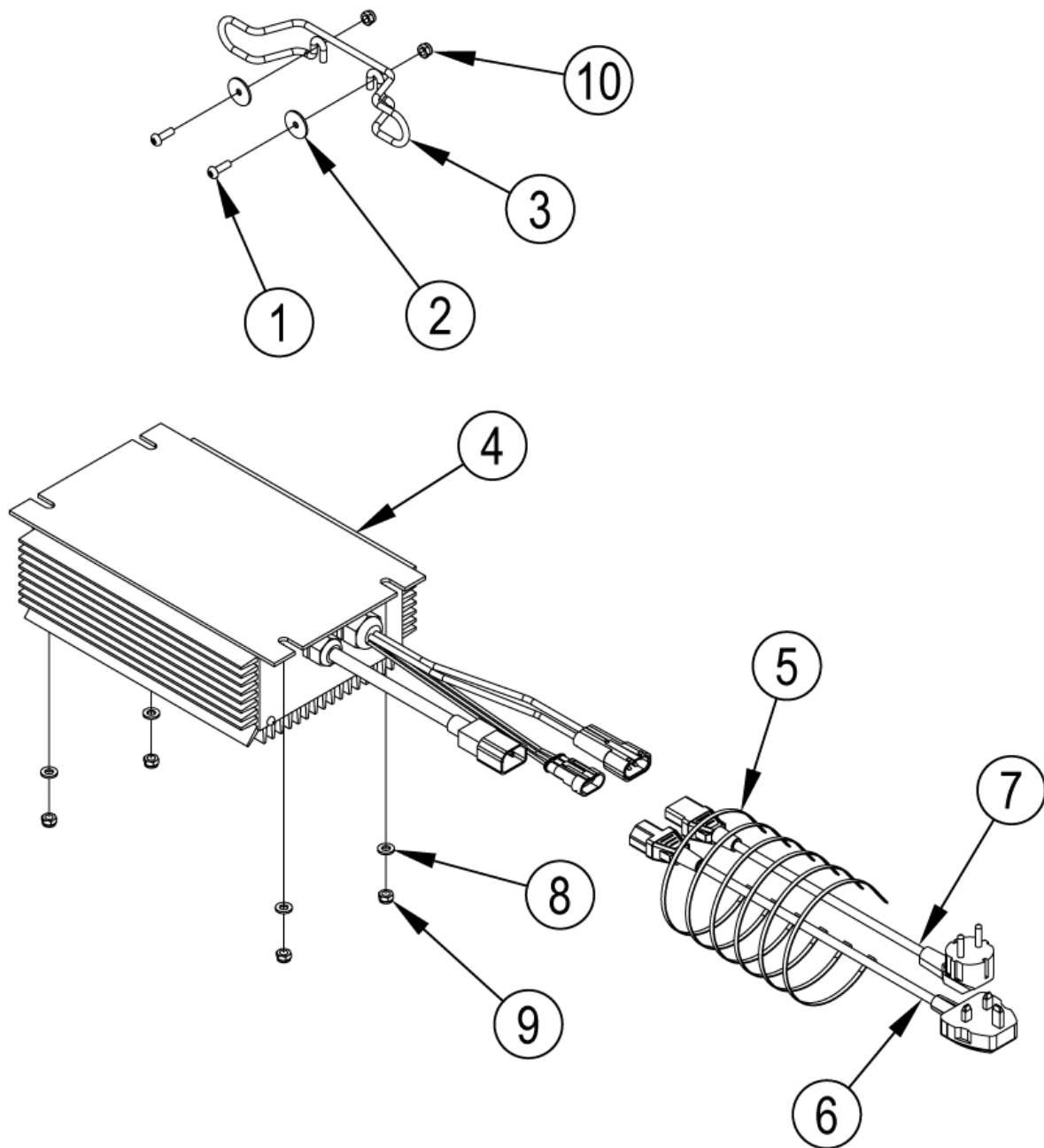

Pos.	Product no	QTY	Description	Notes
00	56104403	1	ON BOARD CHARGER-EU KIT	
1	L08603744	2	SCREW M5X16 PAN HD PHIL SS ISO7045	
2	145 8280 000	2	WASHER PLAIN M5X15 SS ISO7093	
3	1466317000	1	SUPPORT BATTERY CHARGER CABLE KIT	
4	56114378	1	BATTERY CHARGER 24V 25A	
5	56478523	6	CABLE TIE E00549	
6	56383388	1	CORD-CHARGER EUROPE	
7	56383389	1	CORD-CHARGER UK	
8	L08603689	4	WASHER PLAIN M6X18 SS ISO7093	
9	33023667	4	NUT LOCK HEX M6 LOW ISO10511 5 PCS SET	
10	33023194	2	NUT LOCK HEX M5 LOW ISO10511 10 PCS SET	

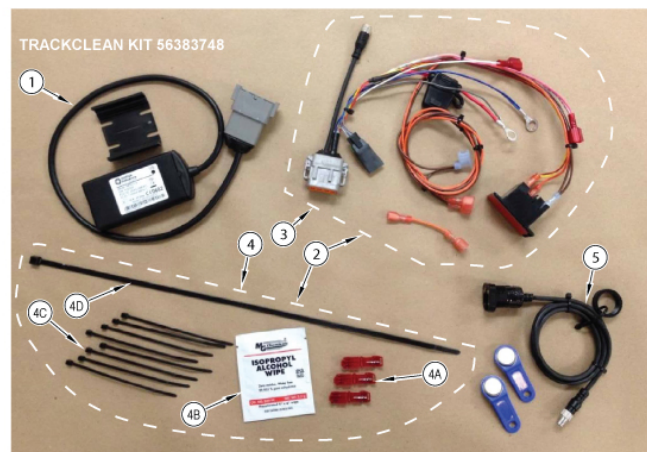
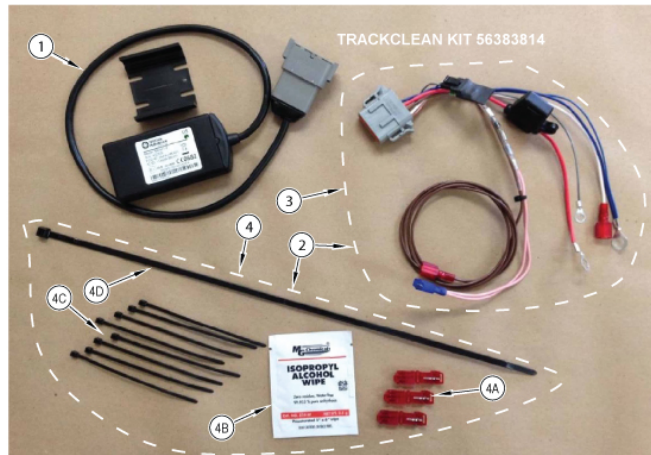

Pos.	Product no	QTY	Description	Notes
0	56383748	1	TRKCLN SC1500 KIT-RDR	[1]
0	56383814	1	TRKCLN SC1500 KIT	[1]
1		1	ME401-9 EU SIM card module (module, bracket)	
2		1	TrackClean System without reader	
3		1	Harness without reader	
4		1	Hardware Kit	
4A		3	Red tap 18-22 AWG (Wire Splice Connector)	
4B		1	Alcohol wipe	
4C		8	Cable tie, 4" x 0.10", black	
4D		1	Cable tie, 8" x 0.18", black	
5		1	TrackClean reader kit (reader, 2 user keys)	

Part Notes:

[1] - IS56090225_trackclean kit

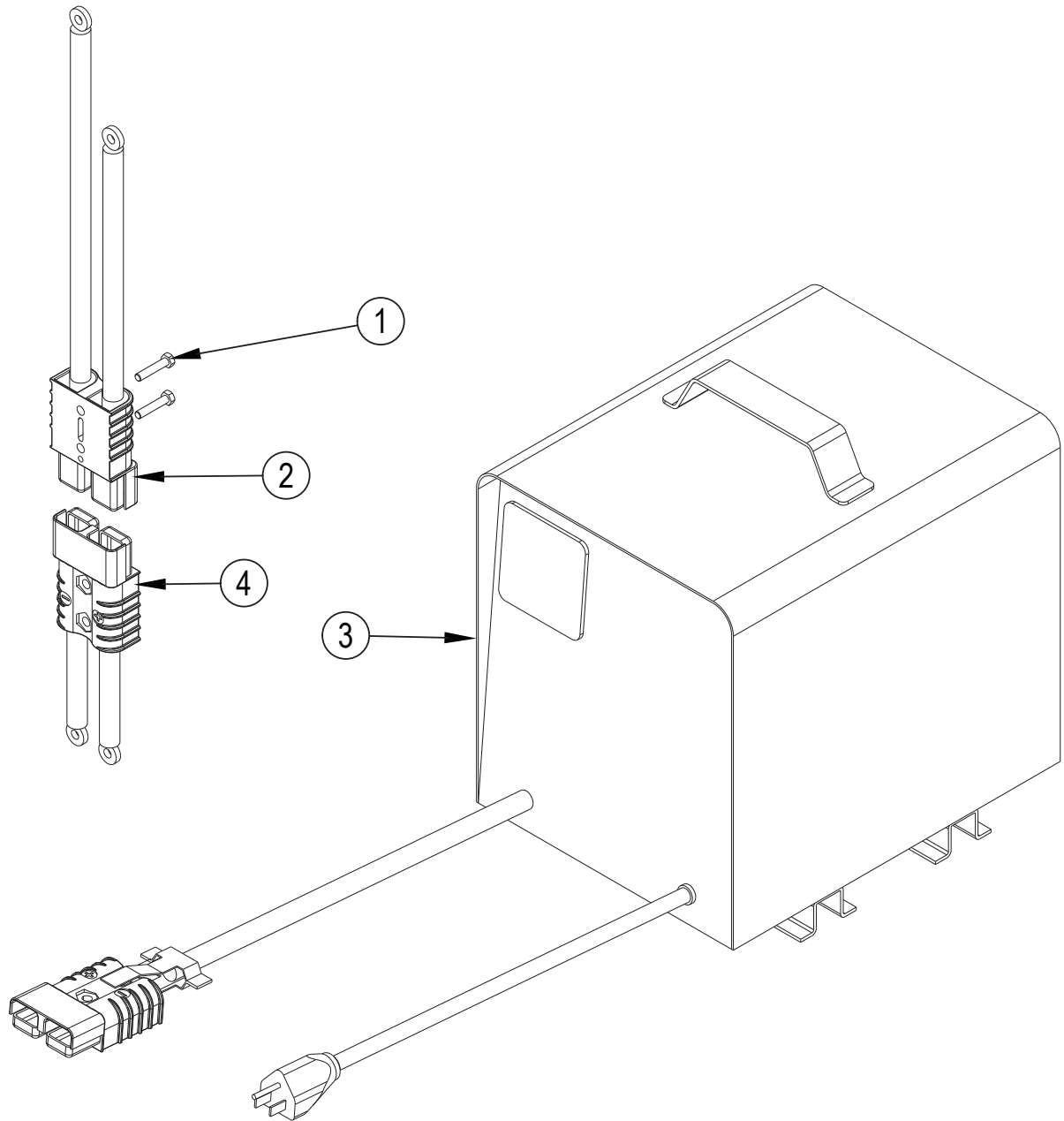

Pos.	Product no	QTY	Description	Notes
0	56104437	1	SHELF CHARGER ADAPTER KIT	[1]
1	33003964	2	SCREW M5X25 HEX HD F/THD ISO4017	
2	56104281	1	CABLE-POWER	
3	56385281	1	CHARGER-BATT SHELF-24V-25A	
4	56601172	1	CONNECTOR ASM	

Part Notes:

[1] - ONLY USED IN US

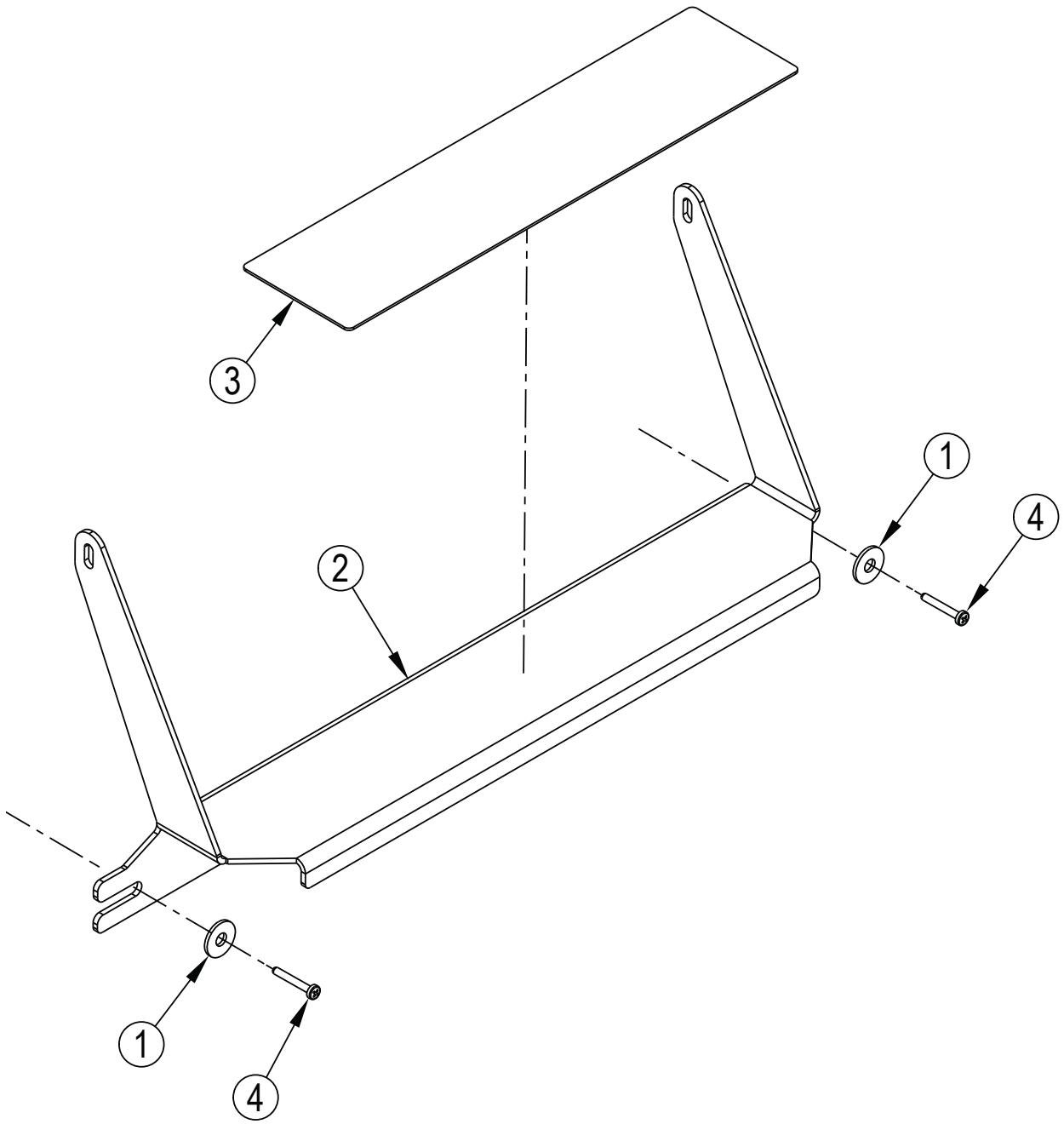

Pos.	Product no	QTY	Description	Notes
	56384040	1		
1	56003638	2	WSH FLT SS M6	
2	56104470	1		
3	56507227	1	MAT PEDAL	
4	56003971	2		

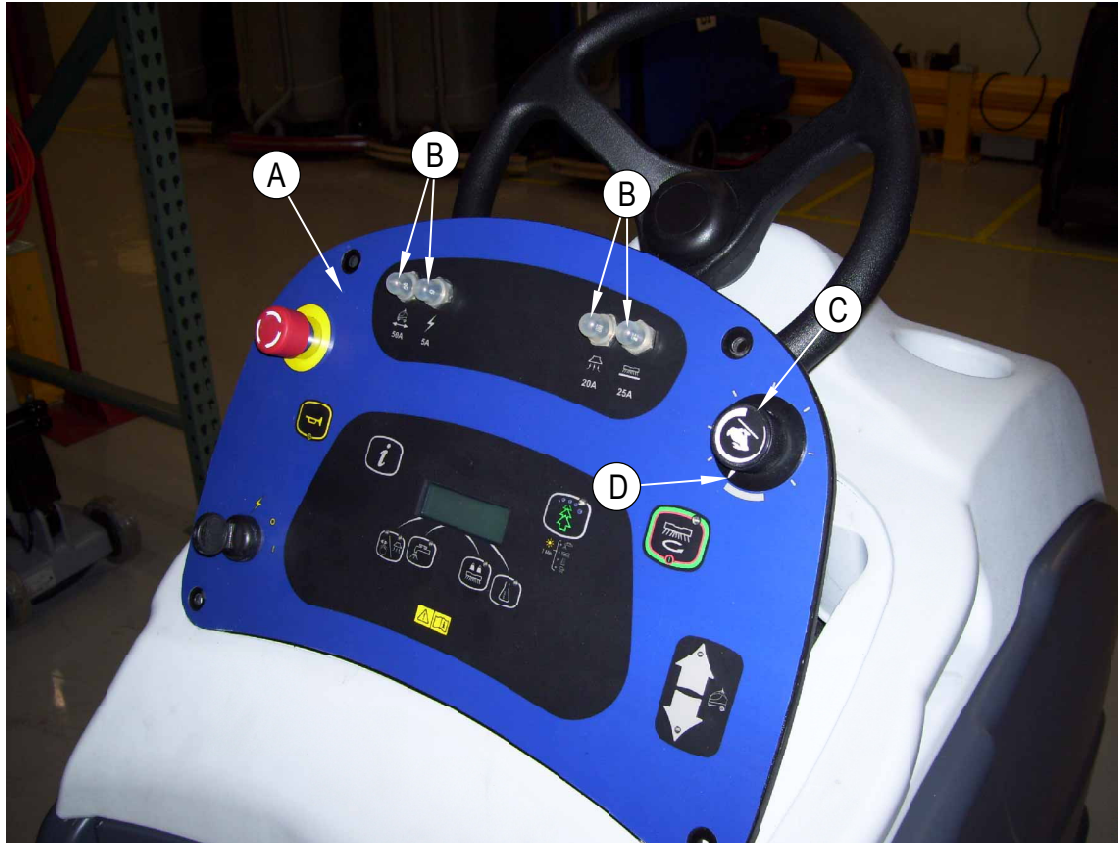

56384204 KIT-CONTROL BOARD

SC1500 51D NIL

2017.11.02

2017.08.28

Pos.	Product no	QTY	Description	Notes
	56384204	1	USER INTERFACE KIT	
1	56384203	1		

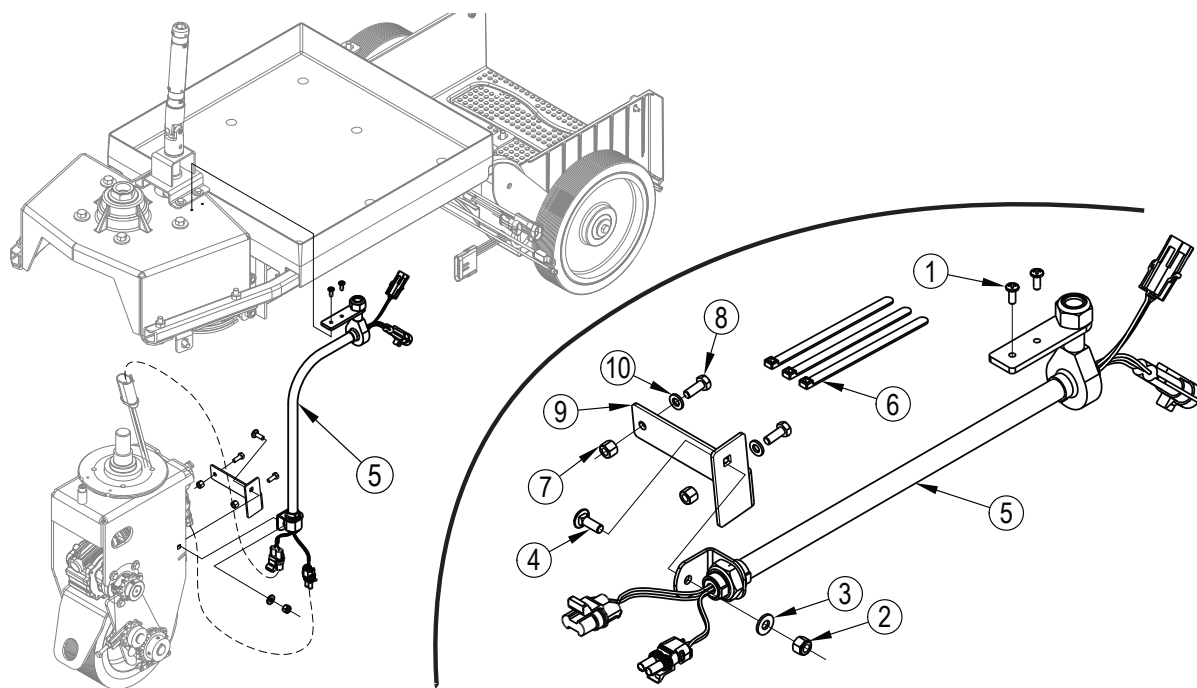

Pos.	Product no	QTY	Description	Notes
	56385136	1	HARNESS DRIVE MOTOR ASSY KIT	[1]
1	56001993	2	SCREW 10-24 X 0.5 ZINC PL	
2	56002491	1	NUT HEX NYL LOC SS 1/4-20	
3		1	Wsh-Ext-Ser-SS-.25	
4		1	Scr-Carriage SS 1/4-20 X .675	
5	56385136	1	HARNESS DRIVE MOTOR ASSY KIT	[1]
6	2-00-04345	3	15.35 IN CABLE TIE BLK NYLON	
7		2	Nut Hex Nyl Loc SS M6	
8	56003431	2	SCR HEX SS M6-1.00X16MM	
9	56385393	1	BRACKET-WHEEL DRIVE HARNESS	
10		2	Wsh, Int Shprf #4	

Part Notes:

[1] - TSB-FC-2018-001 SC1500_SA40 Loss of Drive

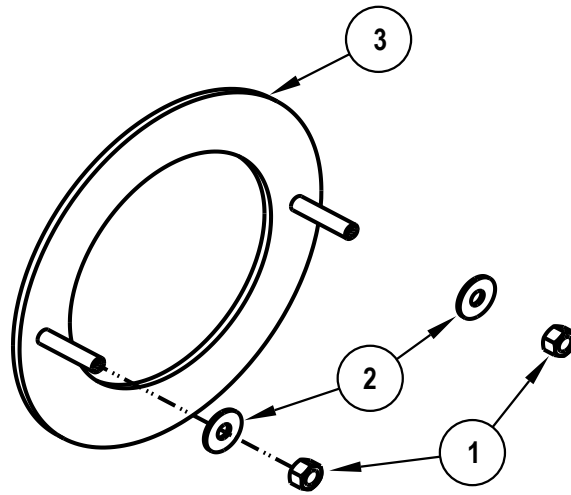

56385105 TANK SUPPORT KIT

SC1500 51D NIL

2017.11.02

2017.08.28

Pos.	Product no	QTY	Description	Notes
	56385105	1	TANK SUPPORT KIT	
1		2	Nut Hex Nyl Loc SS M5-0.8	
2		2	W Sh-Flt SS .202 x .562 x .040	
3		1	Tank Support	

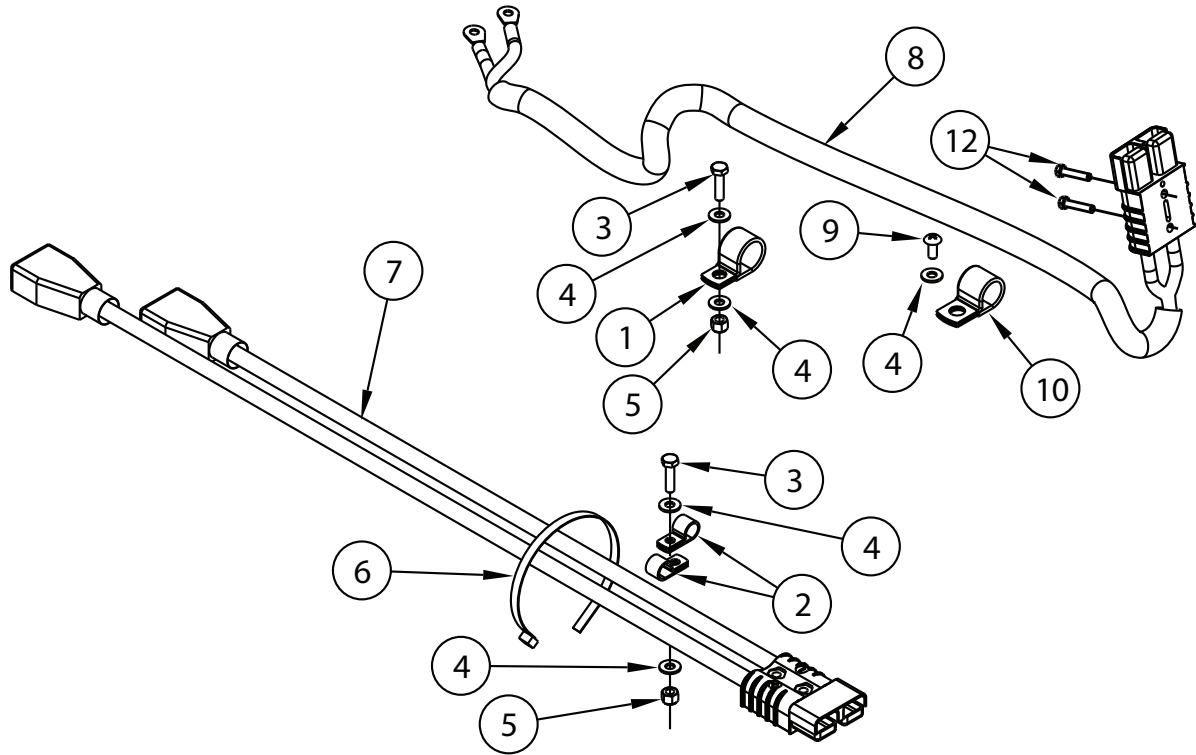

The purpose of this kit is to replace the Upper and Lower Battery Panel Harness Assemblies.

Pos.	Product no	QTY	Description	Notes
	56385490	1	BATT PANEL HARNESS ASSY KIT	[1]
1		1	P-Clamp 1.38" (large)	
2		2	P-Clamp 0.937 (small)	
3		2	Scr-Hex 1/4-20 x 1.00	
4		4	Wsh-Fit SAE SS 1/4	
5		2	Nut, Hex Nyl Loc 1/4-20	
6		1	Cable Tie	
7		1	Lower Battery Harness	
8		1	Upper Battery Harness	
9		1	Screw, PanPhil SS Type B 1/4-14 x .62	
10		1	Clamp, Hose Support (large)	
12		2	Screw M5 x 25 mm Hex Hd F/Thd ISO4017	

Part Notes:

[1] - IS56090357. HARNESS BATTERY - PANEL ASSEMBLY KIT 56385490

TSB-FC-2018-010 SC1500_SA40 Battery Harness Upgrade

DE TSB-FC-2018-010 SC1500 Verbesserung des Batteriekabelbaums

