

PARTS LIST

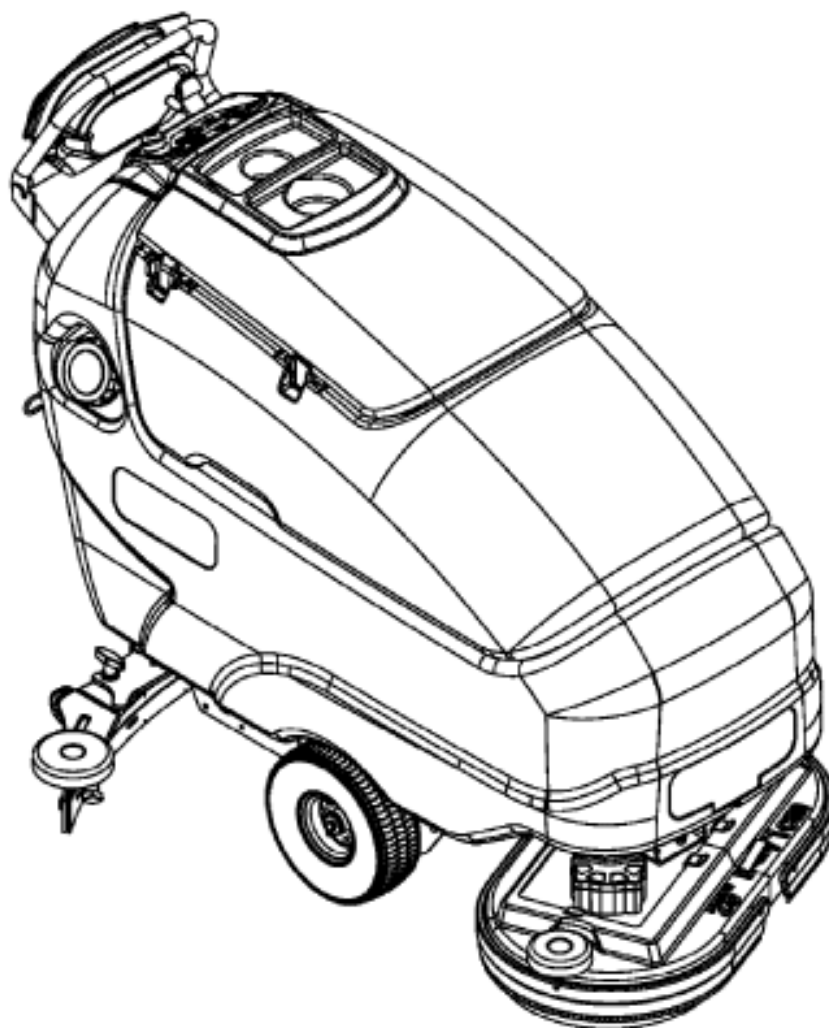

2020.11.18

TABLE OF CONTENTS

Chassis System (Disk).....	1
Chassis System (Cylindrical).....	4
Control System.....	7
Decal System.....	9
Electrical System.....	11
Recovery System.....	14
Scrub System (Disk).....	16
Scrub System (Cylindrical).....	19
Solution System.....	21
Squeegee Assembly.....	23
Squeegee System.....	25
Ladder Diagram After June 2014.....	27
LADDER DIAGRAM BEFORE SN4000068715.....	29
Optional Kits and Accessories.....	31
RECOMMENDED SPARE PARTS.....	34
Brush Selector Guide - Disk.....	38
Brush Selector Guide - Cylindrical.....	40
56112245 - Onboard Charger Kit-EU.....	42
56112140 - Wet Floor Sign Holder Kit.....	44
56112221 - Parking Brake Kit.....	46
56112265 - Kit, 26" Disc Deck 24V.....	48
56112266 - Kit, 28" Disc Deck 24V.....	50
56112267 - Kit, 28" Cylindrical Deck 24V.....	52
56112279 - Kit, 34" Disc Deck 24V.....	54
56112280 - Kit, 32" Cylindrical Deck 24V.....	56
56112138 - Laser Kit.....	58
56112141 - Vacuum Wand with Tote Bag Kit.....	60
56112244 - Chemical Injection Kit.....	62
56112351/56112352 - Control Panel Kits.....	64
56383745 - TRACKCLEAN SC800 KIT-EU.....	66
56383808 - TRACKCLEAN SC800 KIT-EU.....	68

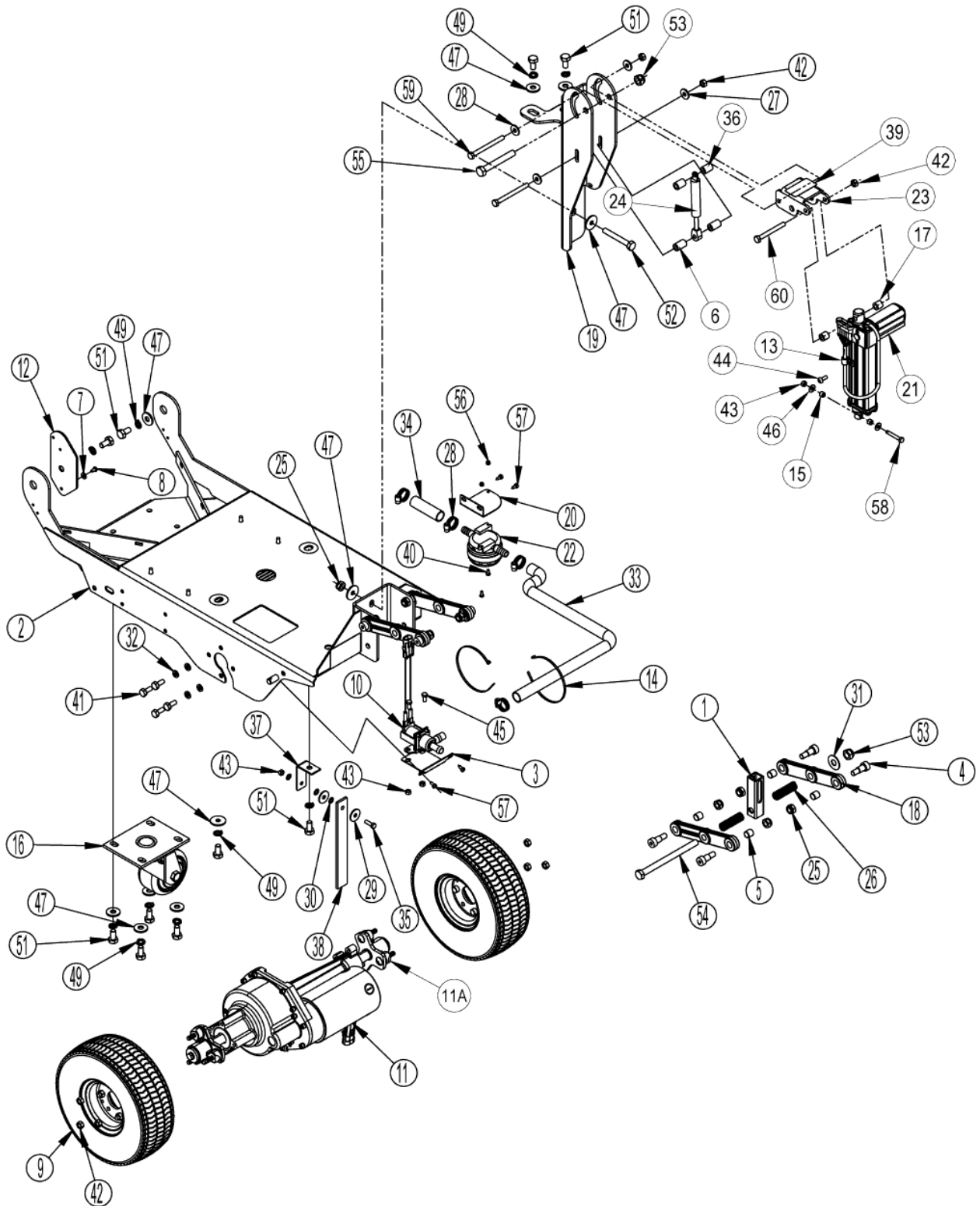

Chassis System (Disk)

SC800 71C NIL

2017.11.02

2019.03.01

Pos.	Product no	QTY	Description	Notes
1	56109717	1	TUBE JACK MOTOR	
2	56112765	1	CHASSIS WELDT	
3	61932A	1	PLATE SOLUTION SYSTEM SUPPORT	
4	88617A	8	SCREW SHOULDER M10-1.5X12X16M	[1]
5	56112548	8	BUSHING	
6	909 6113 000	2	SPACER 8.2X15 H.23.8 GALV.	
7	56001954	1	WSH FLT SAE 10	
8	56009030	1	SCR PAN PHIL THD FOM 10-24X.38	
9	56112109	2	WHEEL-SCRUBBER-10.5 X 3.5	
10	56112147	1	SOLENOID VALVE ASSY	
11	56112543	1	TRANSAXLE	
11A	56382670	1	KIT TRANSAXLE MOTOR	[2]
11A	40628A	4	BRUSH CARBON MOTOR	[3]
11A	56380158	2	FLANGE KIT	[3]
12	56112768	1	CONNECTOR BRKT	
13	56323260	1	CLAMP CABLE	
14	56478523	1	CABLE TIE E00549	
15	1467037000	2	SPACER D.6.1X10 H.6.5 BRASS SIP	
16	56112308	1	CASTER-SWIVEL 4.00 X 2.00	
17	909 6112 000	2	SPACER D.8.2X15 H.14 GALV.	
18	9097197000	4	LEVER BRUSK DECK FIXING ALU	
19	9097368000	1	SUPPORT DECK LIFTING GALV.	
20	9097370000	1	PLATE SUPPORT FILTER GALV.	
21	40280A	1	ACTUATOR BOOST 32	
22	9100000860	1	FILTER WATER SIP	
22	9100000861	1	NET WATER FILTER REINFORCED SIP	[4]
23	9097456000	1	BRACKET ACTUATOR GALV.	
24	54689A	1	GAS SPRING 500N	
25	80223A	9	NUT M10-1.5 NYLOCK	
26	E04016	2	SPRING	
27	56002220	4	WSH FLT STD 5/16	
28	56219932	4	CLAMP HOSE SAE 6 E00047	
29	980205	2	WASHER .312 ID/1.06 OD/.075THK	
30	980614	3	WASHER LK 1/4 EXT TOOTHPLTD	
31	56001879	1	WSH FLT SAE 1/2	
32	980652	8	WASHER LK 5/16 REGPLTD	
33	30828A	1	HOSE	
34	30829A	1	HOSE	
35	56002454	1	SCR SOC HD 10-24 X 1.50	[5]
36	61937A	2	SPACER	
37	61949A	1	BRACKET GROUND STRAP	
38	69639A	1	STATIC STRAP FUSION	
39	71017A	1	LABEL MOVING PARTS	
40	80057A	2	SCREWM4-.7X10 PN PHILLIP SS	
41	56003179	8	SCR HEX THD/HD M8-1.25X20MM	
42	80198A	9	NUT M8-1.25 HEX NYLON S.S.	
43	80199A	4	NUT M6-1 HEX NYLON LOCK S.S.	
44	80208A	1	SCREW M6-1 X 10MM P.P.HD	
45	56003211	2	SCR HEX HD SS M6-1.0 X 12MM	
46	87026A	2	WASHER .250 FLAT SS	[6]
47	87054A	10	WASHER FENDER .375	
49	88612A	10	WASHER M10 LOCK	
51	56003483	10	SCR-HEX M10-1.5 X 20MM	
52	88616A	1	SCREW M10-1.5 X 75MM HEX	
53	56003312	2	NUT HEX NYL LOC M12-1.75	
54	88619A	1	SCREW M12-1.75X160MM HEX ZINC	
55	88620A	1	SCREW M12-1.75 X 90MM HEX	
56	88623A	2	NUT M4-.7 NYLON INSERT	
57	88624A	4	SCREW M5 X 12MM HEX TRILOBE	

Pos.	Product no	QTY	Description	Notes
58	88626A	1	SCREW M6-1 X 40MM HEX	
59	56003390	2	SCR HEX M8X1.25X90MM	
60	88635A	1	SCREW M8-1.25 X 75MM HEX	

Part Notes:

- [1] - EXPIRED USE 56003883
- [2] - (for 56112543) (M1)
- [3] - (for 56112543)
- [4] - (for 9100000362)
- [5] - GUARANTEE DATE EXPIRED
- [6] - EXPIRED USE 56002859

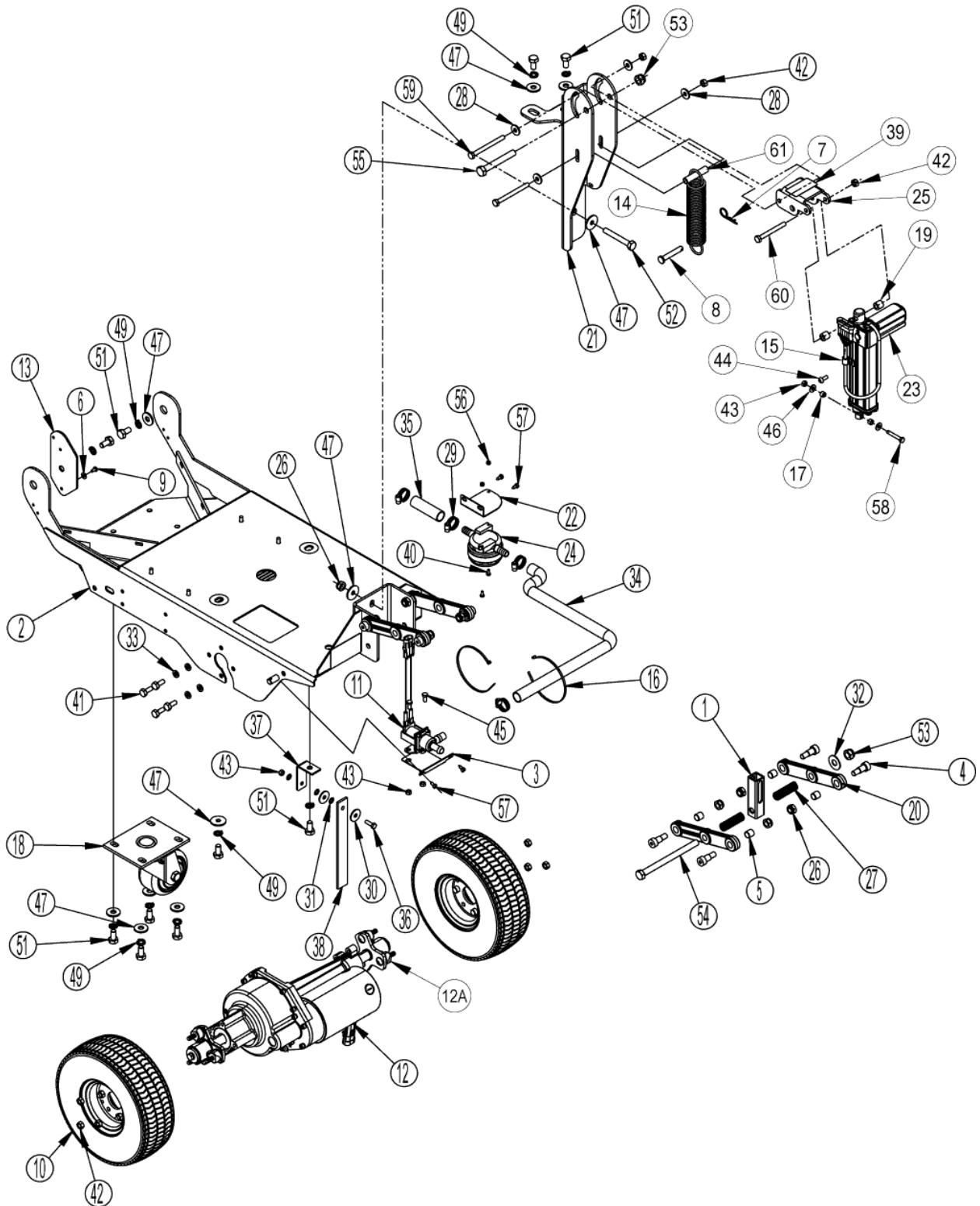

Chassis System (Cylindrical)

SC800 71C NIL

2017.11.02

2019.03.01

Pos.	Product no	QTY	Description	Notes
1	56109717	1	TUBE JACK MOTOR	
2	56112765	1	CHASSIS WELDT	
3	61932A	1	PLATE SOLUTION SYSTEM SUPPORT	
4	88617A	8	SCREW SHOULDER M10-1.5XM12X16M	[1]
5	56112548	8	BUSHING	
6	56001954	1	WSH FLT SAE 10	
7	56002959	1	PIN COT HAIR SS.090XDIA.50/.75	
8	56003656	1	CLEVIS PIN .375 X 2.25	
9	56009029	1	SCR PANPHIL THD FORM 10-24X.50	
10	56112109	2	WHEEL-SCRUBBER-10.5 X 3.5	
11	56112147	1	SOLENOID VALVE ASSY	[2]
12	56112543	1	TRANSAXLE	[3]
12A	56382670	1	KIT TRANSAXLE MOTOR	[4]
12A	56380158	2	FLANGE KIT	[5]
12A	40628A	4	BRUSH CARBON MOTOR	[5]
13	56112768	1	CONNECTOR BRKT	
14	56422075	1	SPRING EXTENSION	
15	56323260	1	CLAMP CABLE	
16	56478523	1	CABLE TIE E00549	
17	1467037000	2	SPACER D.6.1X10 H.6.5 BRASS SIP	
18	56112308	1	CASTER-SWIVEL 4.00 X 2.00	
19	909 6112 000	2	SPACER D.8.2X15 H.14 GALV.	
20	9097197000	4	LEVER BRUSK DECK FIXING ALU	
21	9097368000	1	SUPPORT DECK LIFTING GALV.	
22	9097370000	1	PLATE SUPPORT FILTER GALV.	
23	40280A	1	ACTUATOR BOOST 32	
24	9100000861	1	NET WATER FILTER REINFORCED SIP	[6]
24	9100000860	1	FILTER WATER SIP	
25	9097456000	1	BRACKET ACTUATOR GALV.	
26	80223A	9	NUT M10-1.5 NYLOCK	
27	E04016	2	SPRING	
28	56002220	4	WSH FLT STD 5/16	
29	56219932	4	CLAMP HOSE SAE 6 E00047	
30	980205	2	WASHER .312 ID/1.06 OD/.075THK	
31	980614	3	WASHER LK 1/4 EXT TOOTHPLTD	
32	56001879	1	WSH FLT SAE 1/2	
33	980652	8	WASHER LK 5/16 REGPLTD	
34	30828A	1	HOSE	
35	30829A	1	HOSE	
36	56002454	1	SCR SOC HD 10-24 X 1.50	[7]
37	61949A	1	BRACKET GROUND STRAP	
38	69639A	1	STATIC STRAP FUSION	
39	71017A	1	LABEL MOVING PARTS	
40	80057A	2	SCREWM4-.7X10 PN PHILLIP SS	
41	56003179	8	SCR HEX THD/HD M8-1.25X20MM	
42	80198A	9	NUT M8-1.25 HEX NYLON S.S.	
43	80199A	4	NUT M6-1 HEX NYLON LOCK S.S.	
44	80208A	1	SCREW M6-1 X 10MM P.P.HD	
45	56003211	2	SCR HEX HD SS M6-1.0 X 12MM	
46	87026A	2	WASHER .250 FLAT SS	[8]
47	87054A	10	WASHER FENDER .375	
49	88612A	10	WASHER M10 LOCK	
51	56003483	10	SCR-HEX M10-1.5 X 20MM	
52	88616A	1	SCREW M10-1.5 X 75MM HEX	
53	56003312	2	NUT HEX NYL LOC M12-1.75	
54	88619A	1	SCREW M12-1.75X160MM HEX ZINC	
55	88620A	1	SCREW M12-1.75 X 90MM HEX	
56	88623A	2	NUT M4-.7 NYLON INSERT	
57	88624A	4	SCREW M5 X 12MM HEX TRILOBE	

Pos.	Product no	QTY	Description	Notes
58	88626A	1	SCREW M6-1 X 40MM HEX	
59	56003390	2	SCR HEX M8X1.25X90MM	
60	88635A	1	SCREW M8-1.25 X 75MM HEX	
61	56112520	1	SPACER	

Part Notes:

- [1] - EXPIRED USE 56003883
- [2] - L1
- [3] - replaces 56112343
- [4] - (for 56112543) (M1)
- [5] - (for 56112543)
- [6] - (for 9100000362)
- [7] - GUARANTEE DATE EXPIRED
- [8] - EXPIRED USE 56002859

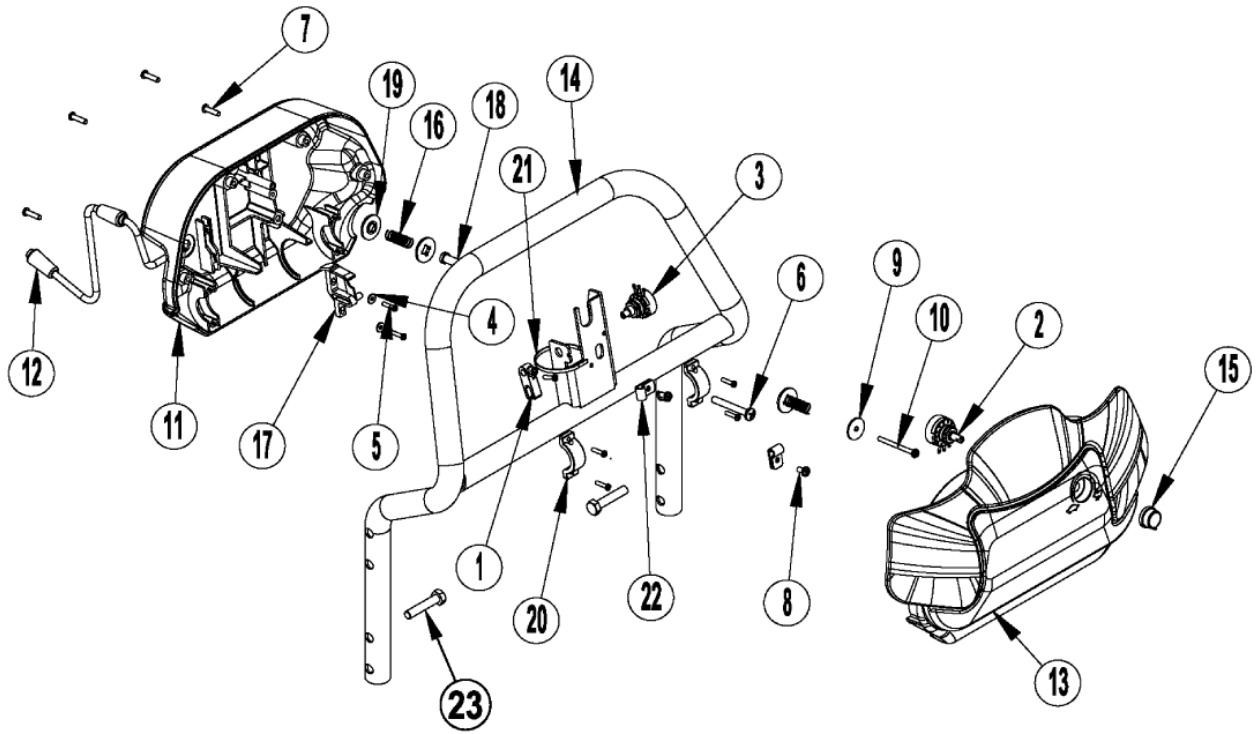

Pos.	Product no	QTY	Description	Notes
	56383361	1	PADDLE-ASSY	[1]
	56112218	1	PADDLE ASSY	[2]
1	56109648	1	POTENTIOMETER FORK	
2	56396197	1	POTENTIOMETER 100K	[3]
3	56397029	1	POTENTIOMETER 5K	[4]
4	56002006	2	WSH FLT SAE 6	
5	56003197	7	SCR PAN PHIL PLASTITE 6-18X.62	
6	56003527	1	SCR PAN PHIL PLAS 1/4-10X2.0	
7	56003545	4	SCR PAN PHIL PLASTITE8-10X.75	
8	56009030	2	SCR PAN PHIL THD FOM 10-24X.38	
9	56009096	1	WSH FLT .193X.875X.060	
10	56009287	1	SCR PAN PHIL TYPE B 8 x 2.00	
11	56109716	1	PADDLE-BACK COVER	
12	56383358	1	HARNESS-PADDLE	[5]
12	56112179	1	HARNESS-PADDLE	[6]
13	56315230	1	PADDLE FRONT COVER	
14	56112767	1	WELDMENT-HANDLE BAR	
15	56315280	1	KNOB	
16	56325654	2	SPRING	
17	56397015	1	CAM CONTROLLER	
18	56397109	1	SLEEVE	
19	56397170	3	WSH PLASTIC	
20	56397171	2	CLAMP	
21	56478246	1	CABLE TIE E00549 RE438BA	
22	56481890	2	CLAMP CABLE .250 E00129	
23	56002094	4	SCR HEX 5/16-18 X 1.50	

Part Notes:

- [1] - (1-22) Only used on machines after serial number 4000068714
- [2] - (1-22) Only used on machines after serial number 4000068714.
- [3] - R2
- [4] - R1
- [5] - Only used on machines after serial number 4000068714.
- [6] - Only used on machines before serial number 4000068715.

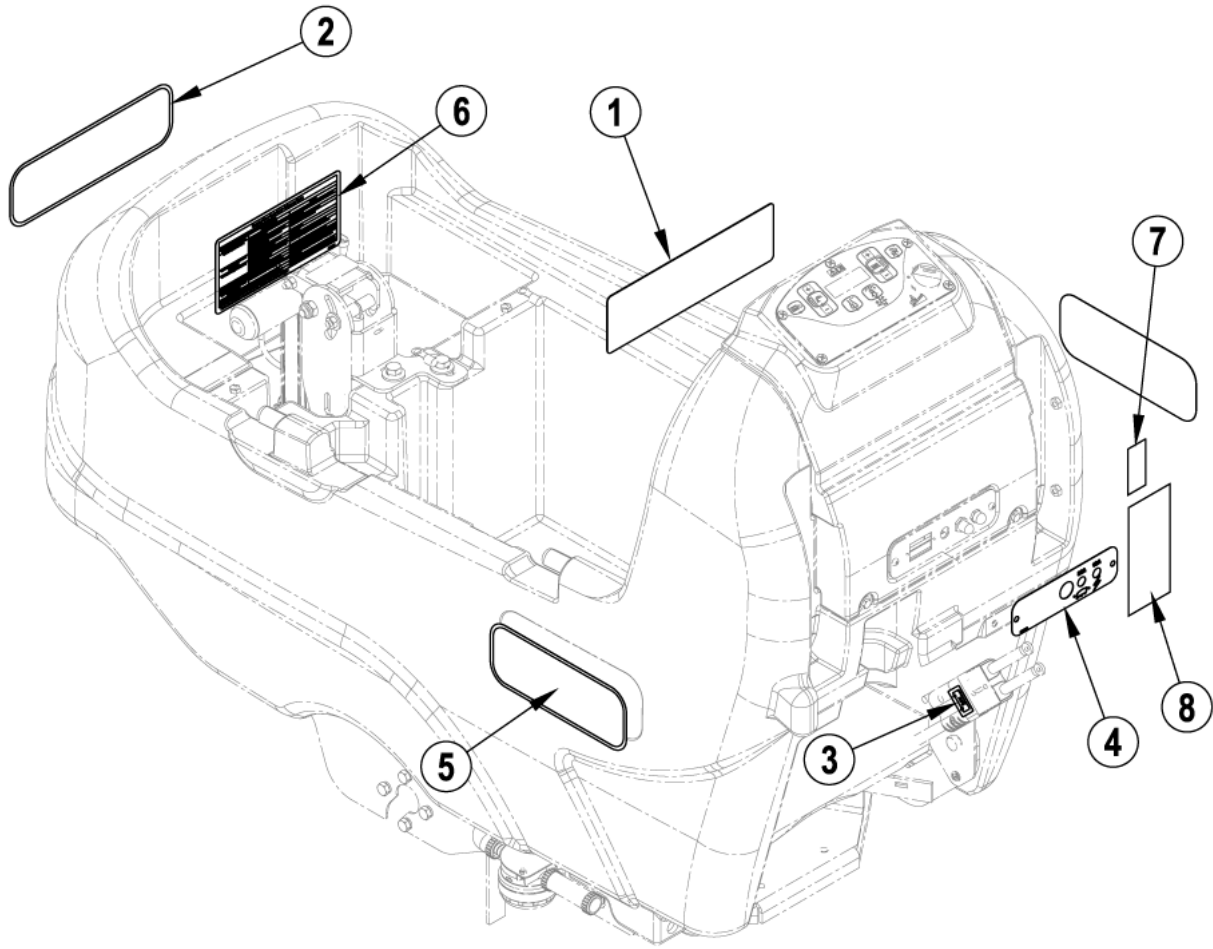

Pos.	Product no	QTY	Description	Notes
1	56014601	1	DECAL CAUTION	
2	56016731	1	DECAL NILFISK	
3	56054192	1	DECAL CHARGER WCA398K	
4	56112168	1	DECAL-CIRCUIT BREAKER	
5	56112531	2	DECAL-NILFISK SC800	
5	56112532	2	DECAL-NILFISK SC800 ECOFLEX	
6	56112292	1	DECAL-ERROR CODES	
7	71362A	1	LABEL NFSI	
8	56112539	1	DECAL-WARNING/WIRING	

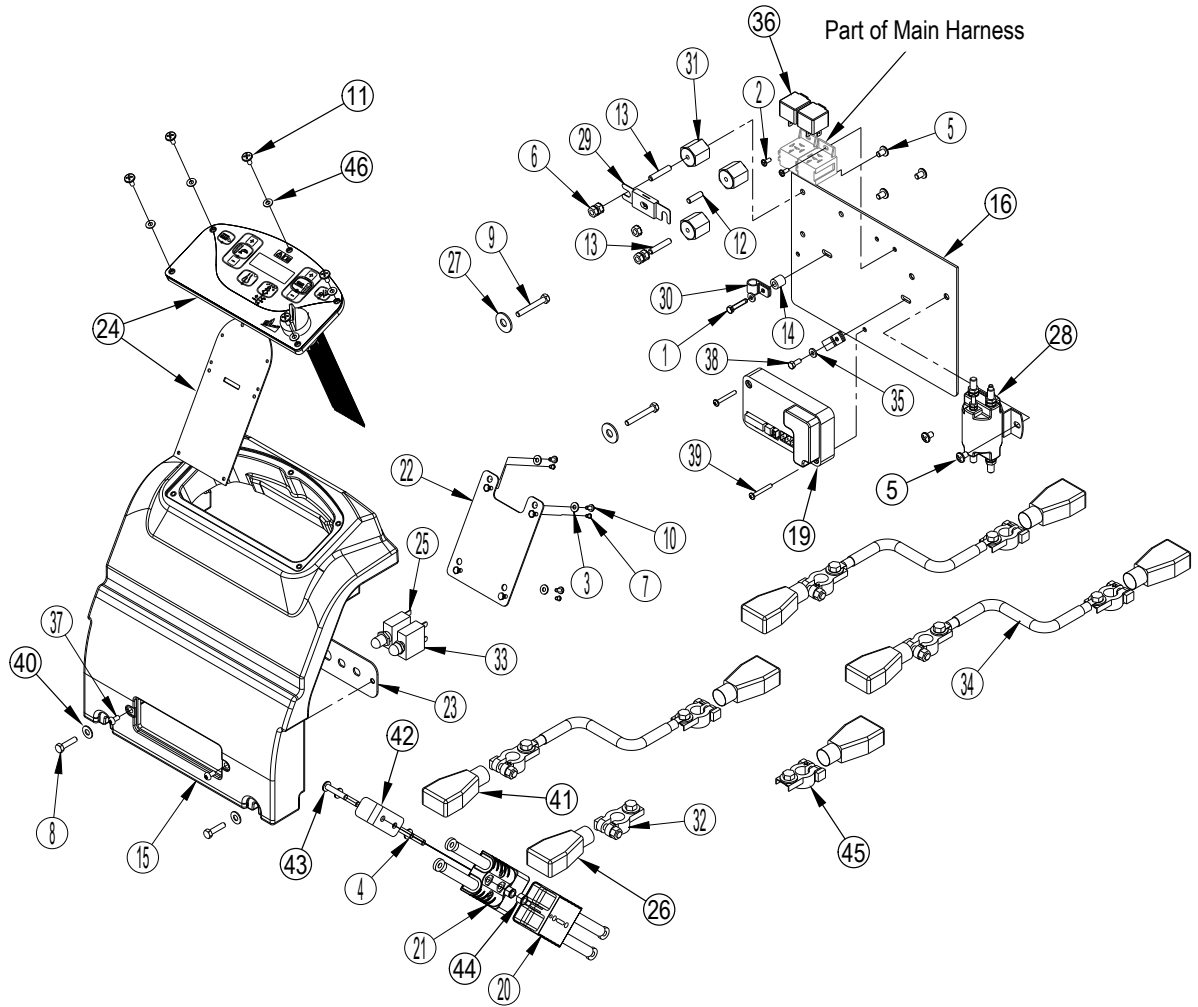

Pos.	Product no	QTY	Description	Notes
1	33003964	1	SCREW M5X25 HEX HD F/THD ISO4017	
2	56001818	2	SCR PAN PHIL 8-32 X .38	
3	56002140	4	WASHER FLAT SAE 8 ZINC PLAT	
4	56002292	2	SCR PAN PHIL 1/4-20 X 1.00	
5	56002462	5	SCR PAN PHIL 1/4-20 X .38	
6	56002561	5	NUT HEX W/SHRPF 1/4/20	
7	56003336	4	SCR PAN PHIL BLK 6-32 X .19	
8	56003695	2	SCR HEX THDTHD SS M6-1.0X25MM	
9	56003631	2	SCR HEX M6-1.0 X 45MM	
10	56003653	4	SCR PAN PHIL M4-0.7 X 8MM	
11	56003808	5	SCR-TRUSS PHIL BLK M5-0.8X12MM	
12	56009020	1	STUD 1/4-20 X .88	
13	56009203	2	STUD 1/4-20X1.31	
14	56046309	1	SPACER PHENOLIC	
15	56112112	1	CONTROL PANEL	
16	56112115	1	ELECTRICAL PANEL	
17	56112169	1	CABLE-JUMPER	
18	56383891	1	HARNESS-MAIN	[1]
18	56112174	1	HARNESS-MAIN	[2]
19	56112187	1	SPEED CONTROLLER 70A 24V	[3]
20	56112188	1	HARNESS-CONNECTOR PANEL	
21	56112189	1	HARNESS-CONNECTOR BATTERY	
22	56112535	1	BRACKET-PCB MOUNT	
23	56383359	1	PLATE-CIRCUIT BREAKER	[4]
24	56112351	1	KIT-AXP CONTROL BOARD	[5]
24	56303526	1	KEY REPLACEMENT SET OF 2	[6]
24	56303553	1	KEY SWITCH ASSEMBLY	
24	56112253	1	KIT-INTERFACE PANEL	[7]
25	56315256	1	CIRCUIT BREAKER 30 AMP	[8]
26	2-00-05173	4	BAT TERMINAL COVER BLK	
27	56385358	2	WSH FLT ZN .392 CL267B E00458	
28	56397088	1	CONTACTOR 24V SPDT	[9]
29	56412089	1	FUSE 150 AMP	[10]
30	56442011	2	CLAMP CABLE .438 E00129	
31	56469858	3	ELECTRICAL MOUNT	
32	910000883	4	CLAMP BATTERY POLE MINUS 2 PCS SET	
33	56507644	1	CIRCUIT BREAKER 10 AMP	[11]
34	56409485	3	CABLE ASSY.1 X 15.00	
35	980643	2	WASHER 7/16ODX.036THK	
36	41075A	2	RELAY	
37	56003346	2	SCR, PAN PHIL M5 X 10.0	[12]
38	80249A	1	SCREWM5-.8X12MM HEX HEAD S.S.	
39	80380A	2	SCREW 8-32 X 1-1/4 PH	
40	87026A	2	WASHER .250 FLAT SS	[13]
41	2-00-05171	4	BAT TERMINAL COVER RED	
42	56112354	1	HANDLE	
43	56002825	2	SCR PAN PHIL 1/4-20 X 1.25	
44	56002708	2	NUT HEX NYL LOC 1/4-20	
45	910000882	4	CLAMP BATTERY POLE PLUS 2 PCS SET	
46	56384075	5	WASHER-BLACK NYLON-6/6	

Part Notes:

- [1] - Only used on machines after serial number 4000068714.
- [2] - Only used on machines before serial number 4000068715.
- [3] - (A2)
- [4] - Circuit Breaker Plates 56112122 and 56112540 are obsolete and have been replaced by 5638359.
- [5] - 56112351/56112352 - Control Panel Kits
- [6] - for 56303553
- [7] - (MEMBRANE SWITCH, MEMBRANE PANEL, GASKET)

- [8] - (CB1)
- [9] - (K2)
- [10] - (F1)
- [11] - (CB2)
- [12] - Closed SEE MI-SP-007
- [13] - EXPIRED USE 56002859

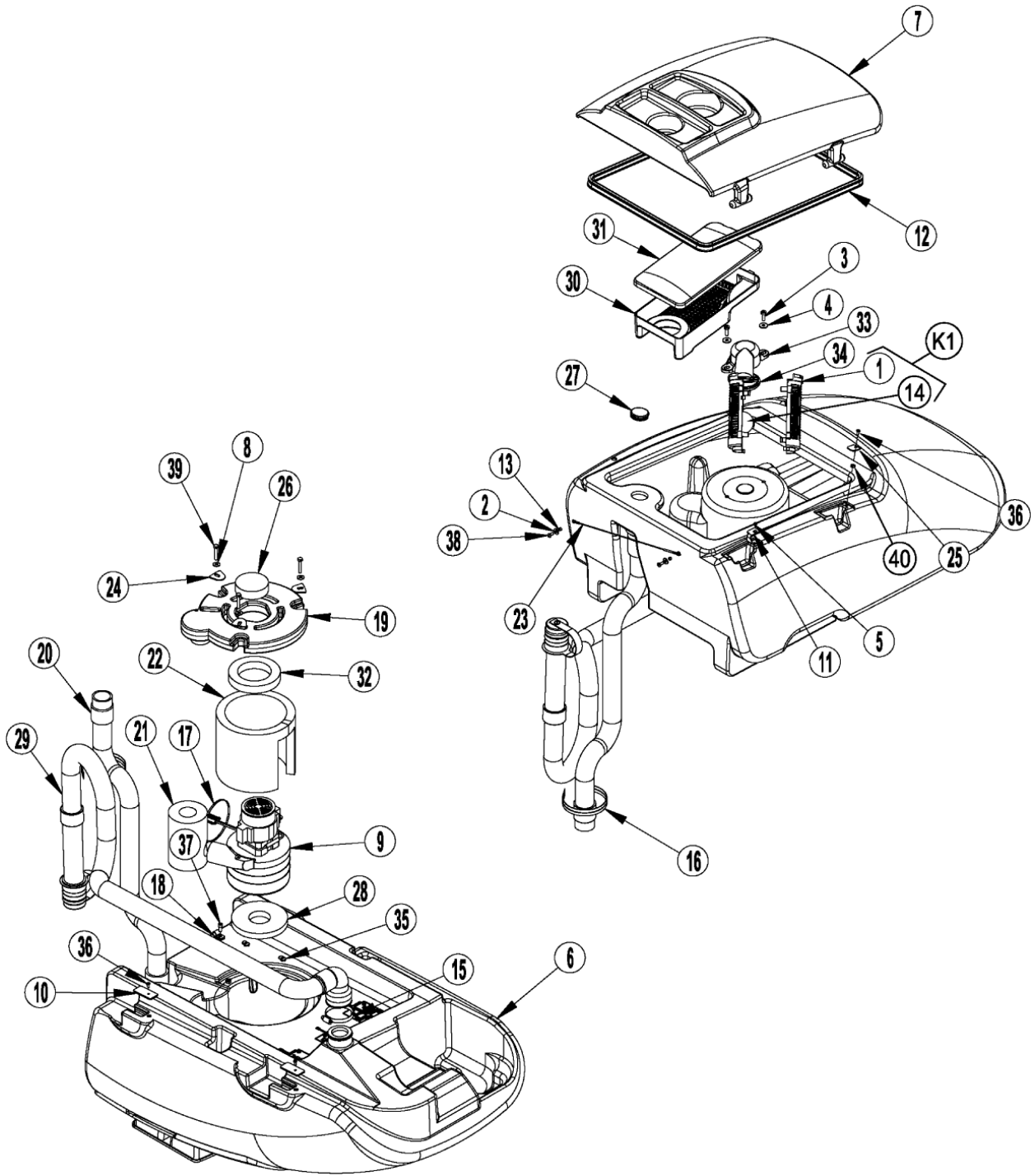

Pos.	Product no	QTY	Description	Notes
1		2	Cage, Float	[1]
2	56001954	2	WSH FLT SAE 10	
3	56003896	2	SCR-PAN PHIL SS M6-1.0 X 20MM	
4	56003638	2	WSH FLT SS M6	
5	56003823	1	SCR-FLT PHIL SS M4-0.7 X 8MM	
6	56112102	1	RECOVERY TANK	
7	56112103	1	RECOVERY LID	
8	87026A	3	WASHER .250 FLAT SS	[2]
9	56384102	1	MOTOR-VAC-24V-DEPHI CONNECTOR	[3]
9	56397098	1	CARBON BRUSH SET	[4]
10	56112293	2	RETAINER PLATE	
11	56112296	1	RETAINER PLATE	
12	56112297	1	GASKET-RECOVERY LID	
13	56151092	2	BUSHING .18X.25X.15G31H	
14		1	Ball, Float	[5]
15	56440213	2	CLAMP HOSE SAE 32E00047	
16	56477613	2	CABLE TIE E00549 RE409S+	
17	56478523	1	CABLE TIE E00549	
18	56323260	2	CLAMP CABLE	
19	9100001246	1	COVER VACUUM MOTOR	
20	56112316	1	HOSE-REC-1.5 X 45	
21	909 6442 000	1	HOSE ACOUSTIC INSULATION L.135MM FOAM	
22	909 6491 000	1	PANEL ACOUSTIC INSULATION FOAM	
23	909 6634 000	1	CABLE SS STOP-LID	
24	909 6638 000	3	PLATE VACUUM COVER	
25	909 6643 000	1	PLATE TANK COVER	
26	56344168	1	FILTER	
27	1466138000	1	CAP BLACK PPL DE 42X11.5 SIP	
28	9096918000	1	GASKET VACUUM MOTOR	
29	56112310	1	DRAIN HOSE-RECOVERY	
30	9097384000	1	TRAY DEBRIS PLAST.	
31	9097477000	1	COVER TRAY DEBRIS PLAST.	
32	9097555000	1	GASKET VACUUM MOTOR	
33	9097587000	1	CAGE FLOAT PLAST.	
34	9100000928	1	GASKET FLOAT SUPPORT PLAST. SIP	
35	9097589000	2	NUT JAW M6X6 SS	
36	80057A	3	SCREWM4-.7X10 PN PHILLIP SS	
37	80208A	2	SCREW M6-1 X 10MM P.P.HD	
38	80363A	2	SCREW M5-.8X12 BT	
39	56003420	3	SCR HEX M6-1.0 X 35MM	
40	909 6679 000	1	BUSH FLANGED	
K1	56112303	1	KIT-FLOAT BALL CAGE	[6]

Part Notes:

- [1] - K1 - CAGE, FLOAT
- [2] - EXPIRED USE 56002859
- [3] - (M5)
- [4] - (for 56112239)
- [5] - K1 - BALL, FLOAT
- [6] - K1

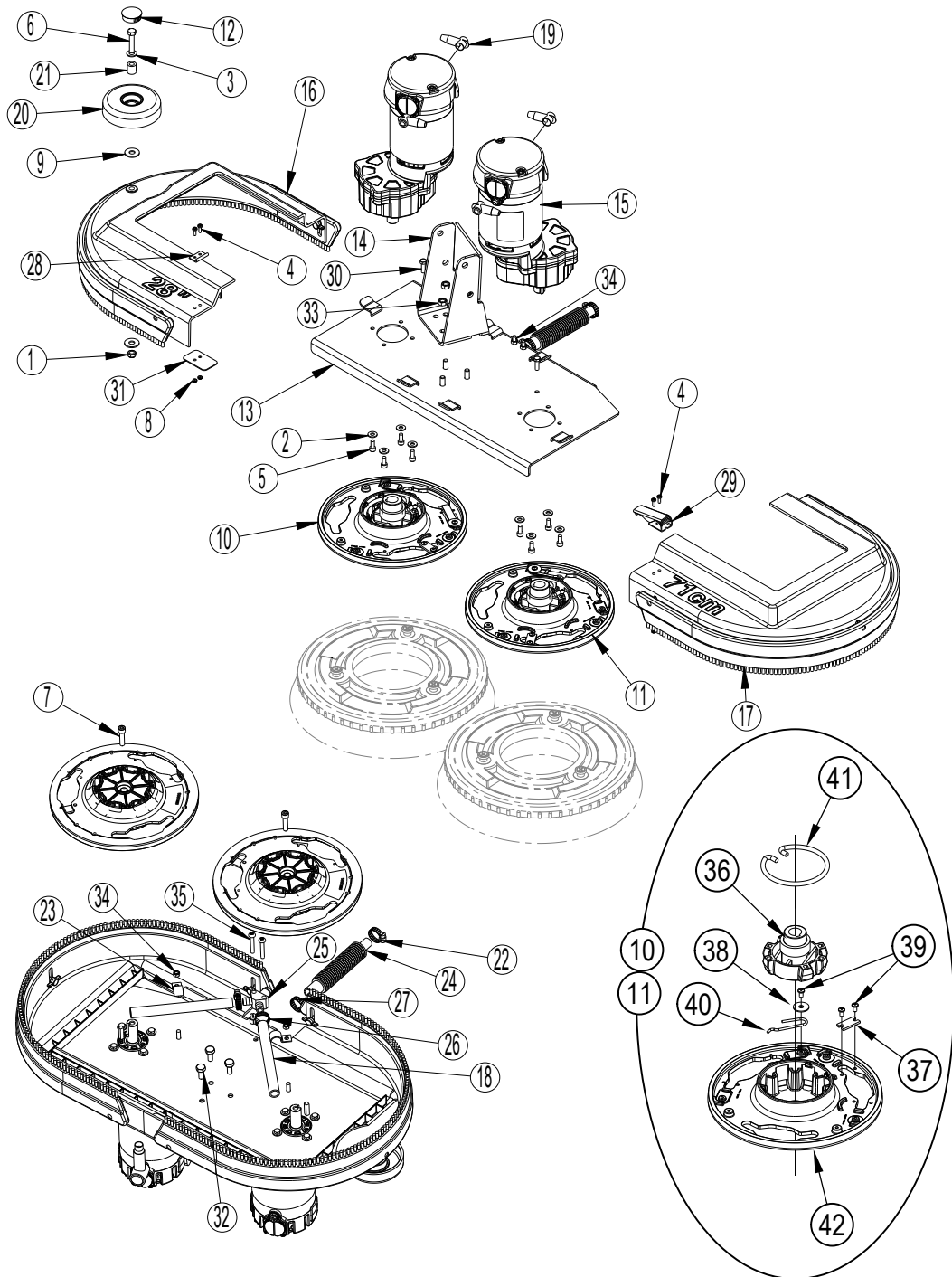

Pos.	Product no	QTY	Description	Notes
1	56002851	1	NUT HEX NYL LOC-THIN SS5/16-18	
2	56002859	8	WSH FLT SAE SS 1/4	
3	56002938	1	WSH FLT SAE SS 5/16	
4	56003948	4	SCR-PAN PHIL SS M4-0.7 X 12MM	
5	56003425	8	SCR SOC SS M6-1X14MM	
6	56003455	1	HEX HD SS 5/16-18 X 1.5	
7	56003798	2	SCR SOC HD 5/16-18 x 1.25	
8	56003949	4	NUT-HEX NYL LOC SS M4-0.7	
9	56009213	2	SH FLT .382X1.000X.075	
10	56109651	1	BRUSH PLATE ASSY-CCW	[1]
11	56109652	1	BRUSH PLATE ASSY-CW	[1]
12	56111444	1	BUTTON PLUG-1.25	
13	56112757	1	BRUSH PLATE WELDT 26D	[2]
13	56112759	1	BRUSH PLATE WELDT 34D	[3]
14	56112523	1	LINKAGE BRACKET WELDMENT	
15	56112242	2	CARBON BRUSH KIT	[4]
15	56112240	2	MOTOR GEARBOX ASSY	[5]
16	56112261	1	BRUSH SKIRT ASSY-34D LEFT	[6]
16	56112259	1	BRUSH SKIRT ASSY-28D LEFT	[2]
17	56112262	1	BRUSH SKIRT ASSY-34D RIGHT	[6]
17	56112307	1	KIT-BRISTLE SKIRT 34	[7]
17	56112306	1	KIT-BRISTLE SKIRT 28	[8]
17	56112260	1	BRUSH SKIRT ASSY-28D RIGHT	[2]
18	30453A	2	HOSE CLEAR VINYL ENCORE	[6]
18	56397207	2	HOSE PVC .500X7.00 E00199	[2]
19	56409538	4	TERMINAL INSULATOR	
20	56601450	1	WHEEL 4.00 OD	
21	56601499	1	BUSHING NYLON	
22	56219932	1	CLAMP HOSE SAE 6 E00047	
23	782002	2	CLAMP-MANIFOLD RM-10	
24	30412A	1	HOSE SOLUTION VISION	
25	38014A	1	SPLITTER SOLUTION ENCORE	
26	50248A	2	CLAMP 3/8 HOSE	
27	53571A	1	CLAMP HOSE	
28	55451A	1	KEEPER BRSH.HSG.ENCORE 28-38	
29	56115427	1	LATCH ASSEMBLY	
30	56002454	2	SCR SOC HD 10-24 X 1.50	[9]
31	69186A	1	TAB LATCH BRUSH ENCORE 33	
32	56003435	3	SCR HEX SS M8-1.25X20MM	
33	80198A	3	NUT M8-1.25 HEX NYLON S.S.	
34	80199A	4	NUT M6-1 HEX NYLON LOCK S.S.	
35	56003950	2	SCR-PAN PHIL SS M6-1.0 X 35MM	
36	56112521	1	GIMBAL-COLLAR ASSEMBLY	
37	56366455	1	PLATE CV24B	
38	56009002	1	WASHER FLAT .266X.906X.060	
39	56009247	3	SCR PN PHIL PLASTITE 10-14X.38	
40	56109653	1	SPRING RETAINER	
41	56601056	1	SPRING BRUSH HOLDER	
42	56601118	1	BRUSH PLATE	

Part Notes:

- [1] - 36-43
 [2] - SC800-71

[3] - SC800-86

NOTE 1: On machines before April 2015, the machines design allowed the Motor Gearbox Assy to interfere with the Recovery Tank causing blown/shorted fuses

and broken electrical stud connections.

NOTE 2: On machines after March 2015, Brush Plate Weldt 34D 56112759 was modified by rotating the Motor Gearbox Assy mounting holes 25 degrees to

allow for a non-interfering motor positioning.

[4] - (for 56112240)

[5] - M3 / M4

[6] - SC800-86

[7] - SC800-86/ INCLUDES TWO SKIRTS AND MOUNTING HARDWARE - NOT SHOWN

[8] - SC800-71/ INCLUDES TWO SKIRTS AND MOUNTING HARDWARE - NOT SHOWN

[9] - GUARANTEE DATE EXPIRED

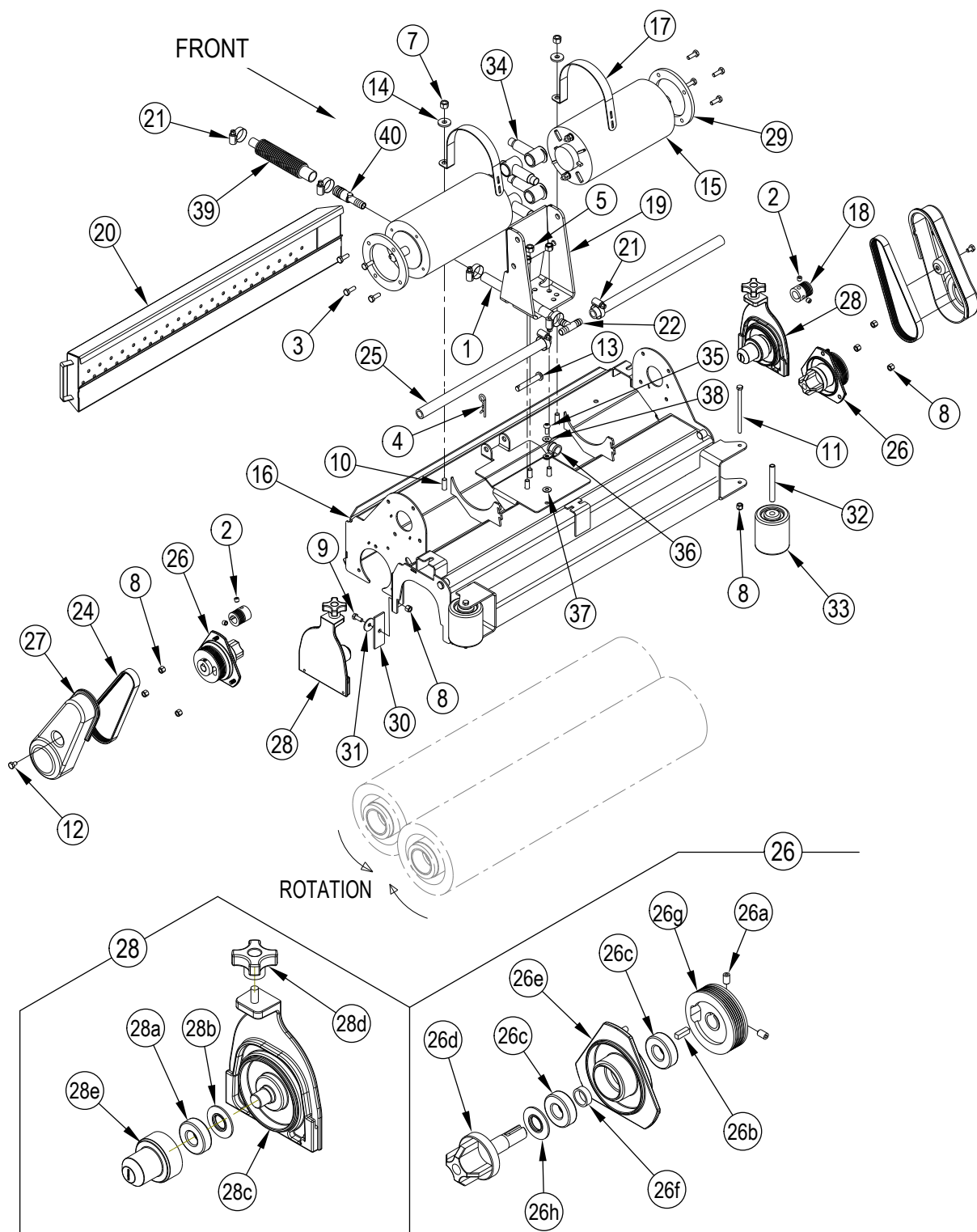

Pos.	Product no	QTY	Description	Notes
1	56397207	1	HOSE PVC .500X7.00 E00199	
2	56002086	4	SCR SOC SET LOC 5/16-18 X .25	
3	56002948	8	SCR HEX LOC-1/4-20 X 0.75	
4	56003222	1	PIN COT HAIR .125 X DIA.50/.75	
5	56003389	3	NUT HEX NYL-LOC M8X1.25	
7	56003405	2	NUT HEX NYL LOC SS M8X1.25	
8	56003426	10	NUT HEX NYL LOC SS M6	
9	56003431	2	SCR HEX SS M6-1.00X16MM	
10	56003436	2	SCR HEX SS M8-1.25X25MM	
11	56003939	2	SCR-HEX SS M6-1 X 95MM	
12	56009019	2	SCR HEX THD FORM 1/4-20X .38	
13	56003656	1	CLEVIS PIN .375 X 2.25	
14	56009122	2	WSH FLT .344X.938X.125	
15	56112111	2	MOTOR-24 VDC 3/4HP	[1]
	56412257	1	BRUSH CAP ASSY	[2]
16	56112760	1	BRUSH HOUSING WELDT-28	
17	56112165	2	STRAP-MOTOR	
18	56112166	2	SHEAVE-POLY-V	
19	56112523	1	LINKAGE BRACKET WELDMENT	
20	56112762	1	HOPPER WELDT-28	
21	56112771	6	CLAMP HOSE SAE 10 E00047	
22	56262549	1	TEE E00455	
24	56315321	2	BELT AUTO TENSION	
25	56315355	2	MANIFOLD PVC 28	
26	56115318	2	DRIVE END ASSY	
26a	56002930	2	SCR SOC SET LOC 1/4-20 X .38	
26b	56003237	1	KEY SQ .19 X .62	
26c	56106070	2	BEARING BALL 6202 Z22	
26d	56115319	1	SPINDLE-LONG	[3]
26e	56381765	1	BEARING PLATE	
26f	56407389	1	SPACER	
26g	56115316	1	SHEAVE-POLY V	[3]
26h	56407558	1	WASHER BEARING	
27	56115314	2	GUARD ASSY-BELT	
28	56115344	2	IDLER END ASSY	
28a	56106070	1	BEARING BALL 6202 Z22	
28b	56407558	1	WASHER BEARING	
28c	56315447	1	IDLER BEARING PLATE	
28d	56407303	1	KNOB	
28e	56115273	1	HUB-IDLER	
29	56316197	2	PLATE MOTOR SPACER	
30	56407391	2	BLADE DECK GUM	
31	56009060	2	WSH FLT SS .260X1.000X.074	
32	56412176	2	BUSHING	
33	56412459	2	WHEEL	
34	56409538	4	TERMINAL INSULATOR	
35	56002066	1	SCR PAN PHIL 1/4-20 X .62	
36	54779A	1	CLAMP P 5/8	
37	56009064	1	WSH INT SHPRF 1/4	
38	87026A	1	WASHER .250 FLAT SS	[4]
39	30412A	1	HOSE SOLUTION VISION	
40	56315625	1	BARB COUPLER 3/4 X 1/2	

Part Notes:

- [1] - M3 / M4
- [2] - for 56112111
- [3] - For machines built before October 2016 items 26d (spindle) and 26g (sheave) must be replaced as a pair, order quantity of one 26d for every 26g being replaced.
- [4] - EXPIRED USE 56002859

Pos.	Product no	QTY	Description	Notes
1	909 6380 000	1	CLAMP KIT	
2	56002918	3	WSH FLT SAE SS 1/2	
3	56054691	1	ADAPTER BARB MALE E00039 BRASS	
4	56109565	1	BARB ADAPTER 1/2 X 3/8 NPT	
5	56112101	1	SOLUTION TANK	
6	56112145	1	TUBE-PRESSURE SENSING	
7	56383997	1	HOSE-PVC-5/8X19	
8	56419275	3	GASKET	
9	56478523	4	CABLE TIE E00549	[1]
10	56112551	1	HOSE	[2]
11	909 5286 000	1	GASKET RUBBER F BARB HOSE D.10	
12	910000803	1	VALVE ELBOW SIP	
13	9097290000	1	HOSE FILLING	
14	59614A	1	VALVE BATTERY DRAINENCORE 33	
15	56112345	1	FILL HOSE SUPPORT	
16	80176A	1	SCREW M5-0.8 X 12MM PPHD SS	
17	56510442	1	CAP-EXTRA VENT	[3]
18	56112775	2	CONNECTOR-STRAIGHT	
19	56116721	2	GROMMET .59X.78X.62IN	
20	34704A	1	HOSE BRUSH VISION 21I	
21	50248A	2	CLAMP 3/8 HOSE	
22	52548A	2	TAB 1/4 SCREW ENCORE 17	[1]
23	80208A	4	SCREW M6-1 X 10MM P.P.HD	[1]
24	56244969	1	CLAMP HOSE SAE 12 E00047	
25	56112552	1	ELBOW 3/16 X 3/16 POLY	[2]
26	56112550	1	HOSE	[2]
27	56009062	2	SCR PAN PHIL THD FORM1/4-20X.5	
28	56323260	4	CLAMP CABLE	
29	56383383	1	POWER CORD BRACKET	
	56112554	1	KIT-SOLUTION LEVEL	
			Service Kits	
K1	56112355	1	KIT-REFILLING HOSE	

Part Notes:

- [1] - The quantity of these parts increased by (1 each) and were implemented in production as of November 6th 2014.
- [2] - Hose 56601273 is obsolete. To replace 56601273 please order Solution Level Kit 56112554.
- [3] - TSB-FC-2015-031 Various machines Solution Fill Cap

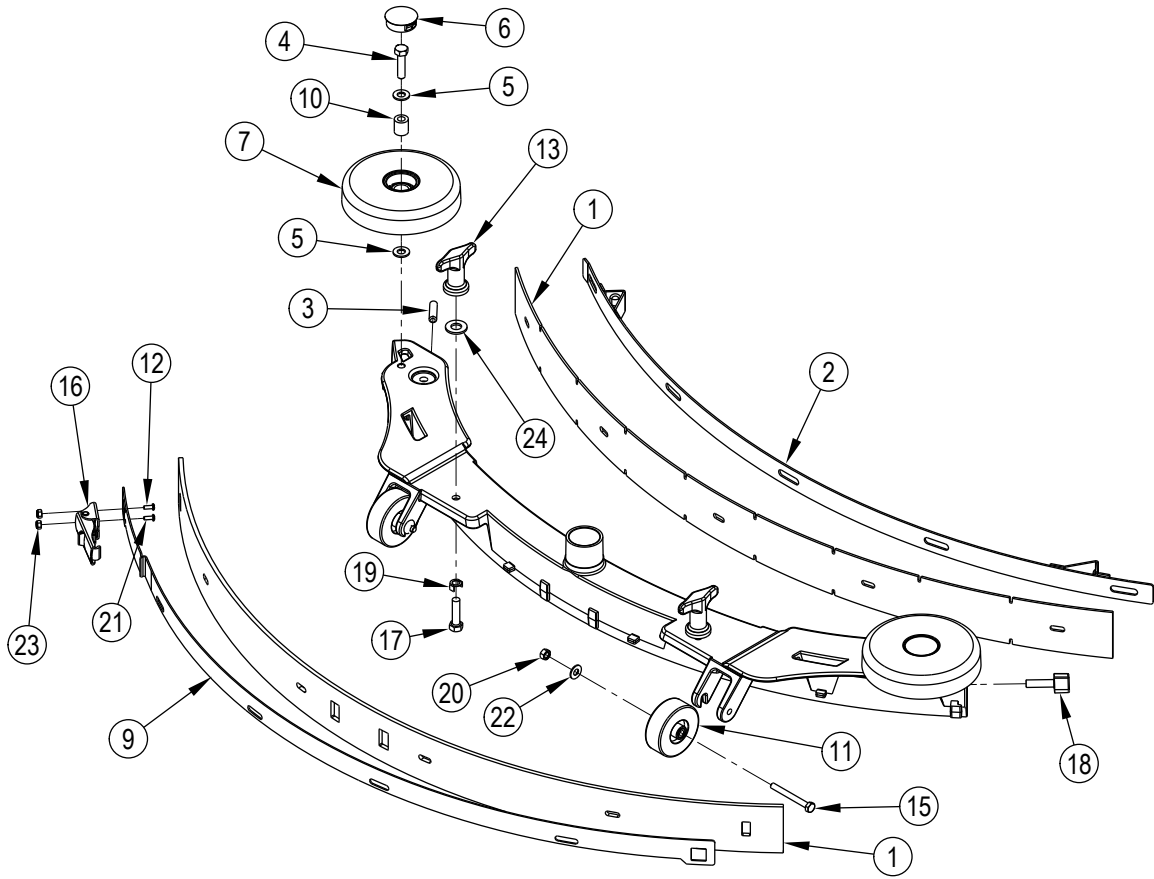

Pos.	Product no	QTY	Description	Notes
	56112314	1	SQUEEGEE ASSY CYL EU	[1]
	56112313	1	SQUEEGEE ASSY	[2]
	56112315	1	SQUEEGEE ASSY	[3]
1	56112330	1	BLADE KIT-SQUEEGEE GUM	[2]
1	56112331	1	BLADE KIT-SQUEEGEE LINATEX	[3]
1	56115334	1	SQUEEGEE KIT-BLADE-GUM	[2]
1	56112330	1	BLADE KIT-SQUEEGEE GUM	[3]
2	60466A	1	STRAP SQUEEGEE FRONT 35	[2]
2	60546A	1	STRAP SQUEEGEE FRONT 41	[3]
3	88632A	1	SCREW SET M8-1.25 X 30MM	
4	56003302	2	SCR HEX THD/HD SS 5/16-18X1.25	
5	56002938	4	WSH FLT SAE SS 5/16	
6	56111444	2	BUTTON PLUG-1.25	
7	56112108	2	WHEEL	
9	56112213	1	STRAP-SQUEEGEE REAR	[2]
9	56115293	1	STRAP ASSY-SQUEEGEE-REAR-42	[3]
10	56601499	2	BUSHING NYLON	
11	909 6883 000	2	WHEELS SQUEEGEE 60X20MM KIT 2PCS	
12	56112300	1	REAR LATCH STRAP	
13	56370711	2	NUT THUMB	
15	88629A	2	SCREW M6-1 X 55MM HEX	
16	9098321000	1	LATCH SQUEEGEE	
17	962157	2	SCR 5/16-18 X 1-1/4 HX ST CAP	
18	54647A	1	KNOB M8X30 SS	
19	60564A	2	SHIM SQUEEGEE KNOB	
20	80199A	2	NUT M6-1 HEX NYLON LOCK S.S.	
21	56002909	2	SCR PAN PHIL SS 6-32 X .38	
22	56002859	2	WSH FLT SAE SS 1/4	
23	56002907	2	NUT HEX NYL LOC SS 6-32	
24	56384502	2	WASHER-POLYURETHANE-1.25	
			Sq ueegee Blade Kits for 56112313	
	56112330	1	BLADE KIT-SQUEEGEE GUM	[4]
	56112331	1	BLADE KIT-SQUEEGEE LINATEX	[5]
	56112332	1	BLADE KIT-SQUEEGEE PU	[6]
	30815U	2	BLADE URETHANE REAR 35	
			Squeegee Blade Kits for 56112315	
	56115334	1	SQUEEGEE KIT-BLADE-GUM	[5]
	56115333	1	SQUEEGEE KIT-BLADE-LINATEX	[7]
	56115335	1	SQUEEGEE KIT-BLADE-PU	[7]

Part Notes:

- [1] - SC800-71C
- [2] - 26" 28" models
- [3] - 32" 34" models
- [4] - Pos. 50-52: SC800-71 Squeegee Blade Kits Pos. 60-62: SC800-86 Squeegee Blade Kits NOTE 1: All squeegee blade kits include both front and rear squeegee blades.
- [5] - NOTE 1: All squeegee blade kits include both front and rear squeegee blades.
- [6] - OPTIONAL, NOT INCLUDED

- NOTE 1: All squeegee blade kits include both front and rear squeegee blades.
- [7] - OPTIONAL, NOT INCLUDED

NOTE 1: All squeegee blade kits include both front and rear squeegee blades.

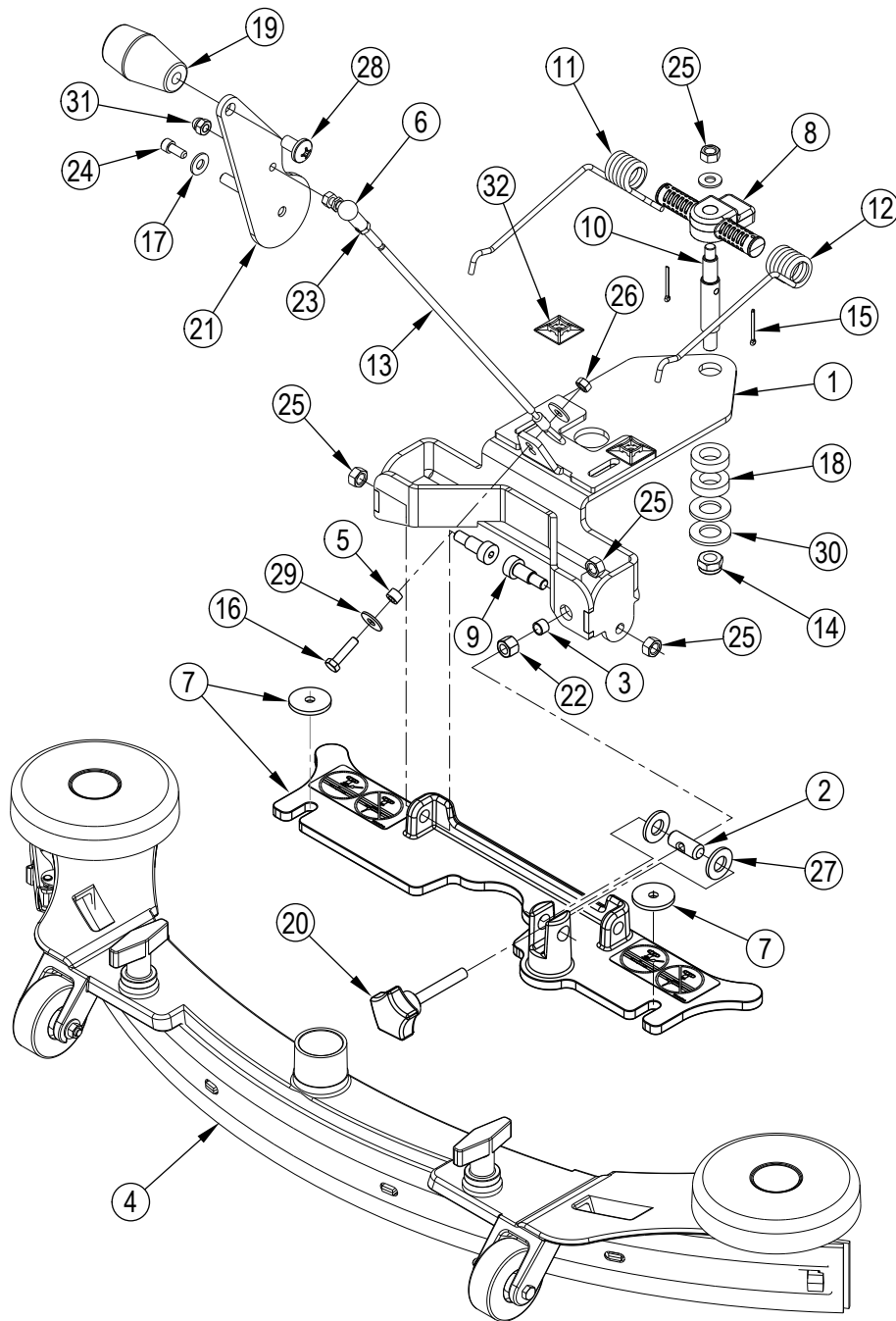

Pos.	Product no	QTY	Description	Notes
1	56112770	1	PLATE-SQUEEGEE WELDT	
2	L08601509	1	PIN MET. SQUEEGEE SUPPORT	
3	L08602422	1	SPACER D.8X10 H.7 SS	
4	56112313	1	SQUEEGEE ASSY	[1]
4	56112315	1	SQUEEGEE ASSY	[2]
5	145 1252 000	1	SPACER D.6.5X10 H.5 GALV.	
6	145 8479 000	1	BALL JOINT M6 DIN71802	
7	56384513	1	SQUEEGEE BRACKET KIT	[3]
8	9100000515	1	SUPPORT SQUEEGEE SPRING PLAST. SIP	
9	9100001160	2	SCREW SHOUL 10X16 M8 ISO7379 10 PCS SET	
10	909 6497 000	1	PIN SQUEEGEE	
11	909 6537 000	1	SPRING TORSION RT GALV. F SQUEEGEE	
12	909 6538 000	1	SPRING TORSION LT GALV. F SQUEEGEE	
13	9097366000	1	CABLE SQUEEGEE LIFTING L.420MM	
14	80223A	1	NUT M10-1.5 NYLOCK	
15	925044	2	PIN-3/32X1 COTTER	
16	56003695	1	SCR HEX THDTHD SS M6-1.0X25MM	
17	56001939	2	WSH FLT SAE 5/16	
18	38708A	2	SPACER 1.120DX.63IDX.30THK	
19	52557A	1	KNOB SQUEEGEE LIFT ENCORE17	
20	54699A	1	KNOB M8 X 55	
21	61952A	1	LEVER SQUEEGEE LIFT	
22	56003352	1	NUT HEX M8	
23	80171A	1	NUT M6-1 HEX	
24	80179A	1	SCREW M6-1 X 16MM PHD PH SS	
25	80198A	4	NUT M8-1.25 HEX NYLON S.S.	
26	80199A	1	NUT M6-1 HEX NYLON LOCK S.S.	
27	80424A	2	WASHER NYLON 1 X 1/2 X .100	
28	85389A	1	SCR 3/8 -16X 5/8 PN SY	
29	87007A	2	WASHER-CONTROL SHAFT ECCENTRIC	
30	87613A	2	WASHERFLT1.22X.64X.10 NYLON	
31	88640A	1	NUT M6-1 ACORN ZINC PLATED	
32	909 6635 000	2	HOLDER.FLAT TIE	

Part Notes:

- [1] - (26" 28" models / Includes Gum Rubber Blades)
- [2] - (32" 34" models / Includes Gum Rubber Blades)
- [3] - TSB-FC-2014-031 Squeegee Brackets Breaking

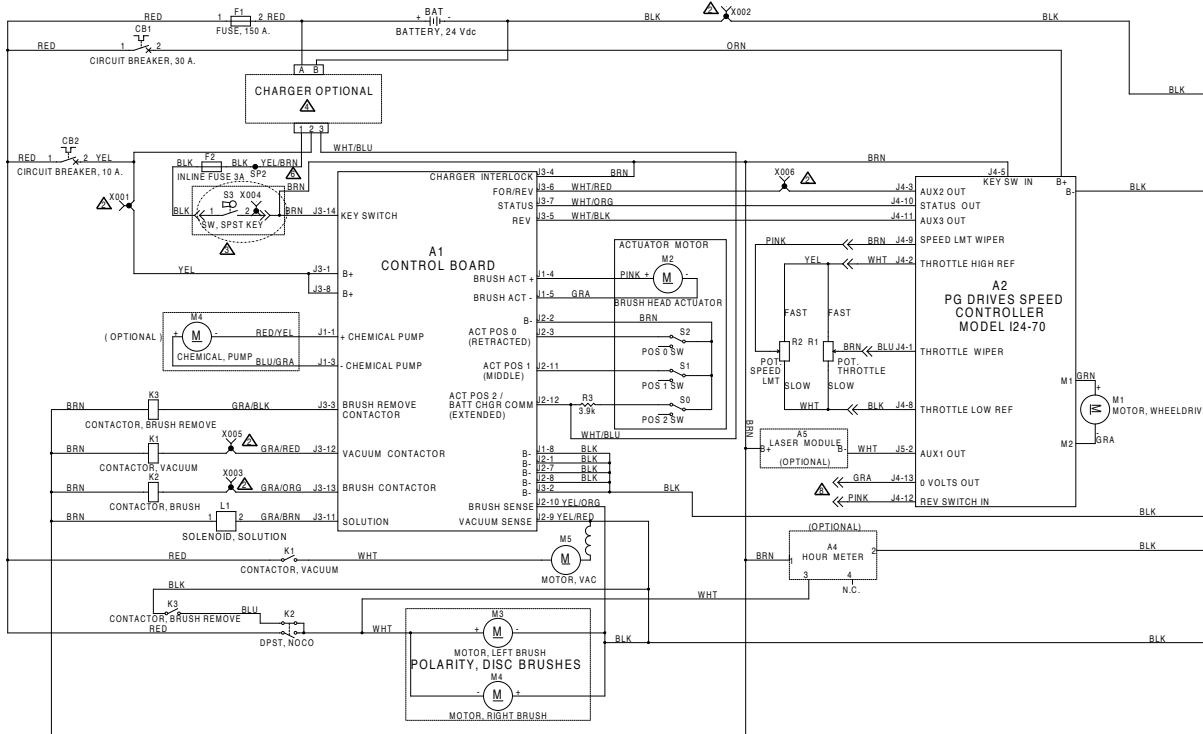

NOTES:

- ▲ CONNECTORS WITH X00X ARE TRACKCLEAN CONNECTIONS.
- ▲ IF TRACKCLEAN OPTION IS INSTALLED, REFER TO TRACKCLEAN CONNECTIONS AND EITHER DETAIL A OR B.
- ▲ REFER TO CHARGER CONNECTIONS FOR ONBOARD CHARGER CONFIGURATIONS.
- ▲ SEE KEY SWITCH DETAIL FOR TRACK CLEAN CONNECTIONS.
- ▲ USED FOR REVERSE SWITCH ON ST MACHINE

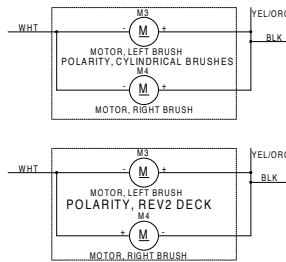

▲ TRACKCLEAN CONNECTIONS (OPTIONAL)

- X001 - B+ (RED)
 - X002 - B- (BLUE)
 - X003 - SCRUB (WHITE)
 - X004 - KEY SWITCH (BROWN)
 - X005 - VACUUM (GRAY)
 - X006 - DRIVE (PINK)
 - X007
 - X008
 - X009
- } SEE DETAIL DIAGRAMS

▲ DETAIL A - WITH ACCESS CONTROL

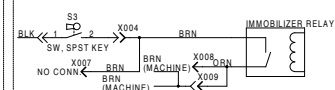

▲ DETAIL B - WITHOUT ACCESS CONTROL

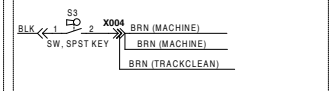

▲ CHARGER OPTIONS

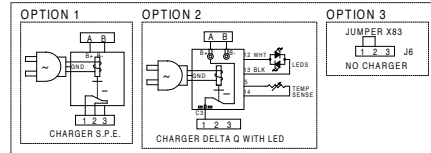

Pos.	Product no	QTY	Description	Notes
A1	56112351	1	KIT-AXP CONTROL BOARD	[1]
A2	56112187	1	SPEED CONTROLLER 70A 24V	
A3	56114378	1	BATTERY CHARGER 24V 25A	
A4	56393718	1	HOURMETER	
A5	56112136	1	LASER	
BAT			Battery-24VDC	
F1	56412089	1	FUSE 150 AMP	
CB1	56315256	1	CIRCUIT BREAKER 30 AMP	
CB2	56507644	1	CIRCUIT BREAKER 10 AMP	
K1	41075A	1	RELAY	
K2	56397088	1	CONTACTOR 24V SPDT	
K3	41075A	1	RELAY	
L1	56112147	1	SOLENOID VALVE ASSY	
M1	56382670	1	KIT TRANSAXLE MOTOR	
M2	40280A	1	ACTUATOR BOOST 32	
M3	56112240	1	MOTOR GEARBOX ASSY	
M3	56112111	1	MOTOR-24 VDC 3/4HP	
M4	56112240	1	MOTOR GEARBOX ASSY	
M4	56112111	1	MOTOR-24 VDC 3/4HP	
M5	56384102	1	MOTOR-VAC-24V-DEPHI CONNECTOR	
M6	56315241	1	PUMP CHEMICAL	
R1	56397029	1	POTENTIOMETER 5K	
R2	56396197	1	POTENTIOMETER 100K	
R3		1	Part of Main Wiring Harness	
S0		1	Part of M2	
S1		1	Part of M2	
S2		1	Part of M2	
S3	56303553	1	KEY SWITCH ASSEMBLY	

Part Notes:

[1] - 56112351/56112352 - Control Panel Kits

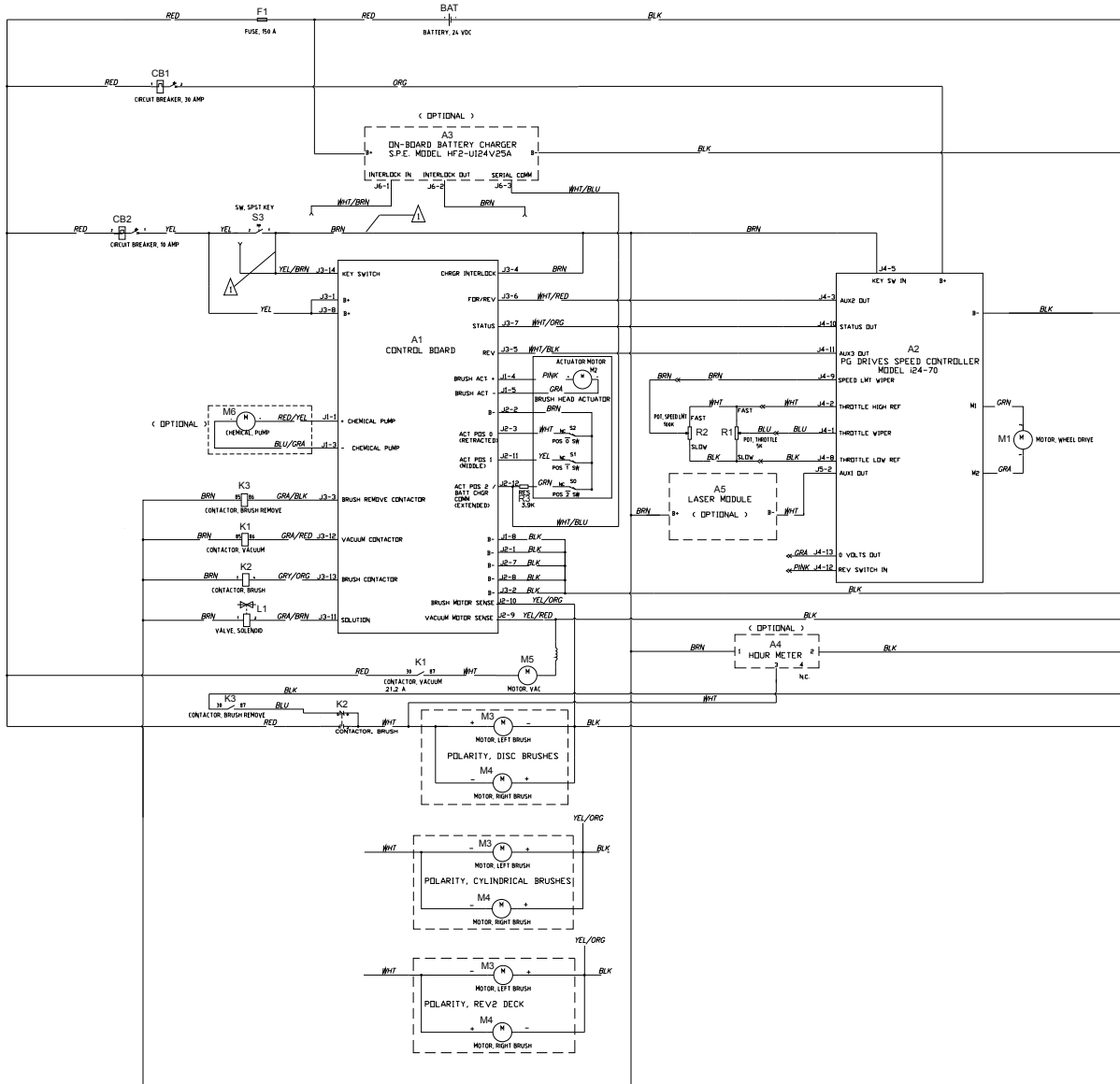

NOTES:
 ⚠ WHEN ON-BOARD CHARGER IS USED, REMOVE BRN WIRE FROM KEY SW. CONNECT TO BRN WIRE FROM BATTERY CHARGER, & REPLACE WITH WHT/BRN WIRE FROM CHARGER. ALSO, MOVE YEL/BRN WIRE AT KEY SWITCH FROM BRN to YEL.

Pos.	Product no	QTY	Description	Notes
A1	56112351	1	KIT-AXP CONTROL BOARD	[1]
A2	56112187	1	SPEED CONTROLLER 70A 24V	
A3	56114378	1	BATTERY CHARGER 24V 25A	
A4	56393718	1	HOURMETER	
A5	56112136	1	LASER	
BAT			Battery-24VDC	
F1	56412089	1	FUSE 150 AMP	
CB1	56315256	1	CIRCUIT BREAKER 30 AMP	
CB2	56507644	1	CIRCUIT BREAKER 10 AMP	
K1	41075A	1	RELAY	
K2	56397088	1	CONTACTOR 24V SPDT	
K3	41075A	1	RELAY	
L1	56112147	1	SOLENOID VALVE ASSY	
M1	56382670	1	KIT TRANSAXLE MOTOR	
M2	40280A	1	ACTUATOR BOOST 32	
M3	56112240	1	MOTOR GEARBOX ASSY	
	56112111	1	MOTOR-24 VDC 3/4HP	
M4	56112240	1	MOTOR GEARBOX ASSY	
	56112111	1	MOTOR-24 VDC 3/4HP	
M5	56384102	1	MOTOR-VAC-24V-DEPHI CONNECTOR	
M6	56315241	1	PUMP CHEMICAL	
R1	56397029	1	POTENTIOMETER 5K	
R2	56396197	1	POTENTIOMETER 100K	
R3		1	Part of Main Wiring Harness	
S0		1	Part of M2	
S1		1	Part of M2	
S2		1	Part of M2	
S3	56303553	1	KEY SWITCH ASSEMBLY	

Part Notes:

[1] - 56112351/56112352 - Control Panel Kits

Pos.	Product no	QTY	Description	Notes
			Kits	
	56112245	1	KIT-ON BOARD CHARGER-EU	
	56112141	1	KIT-VAC WAND WITH TOTE BAG	
	56601527	1	KIT BATTERY WATERING	[1]
	56302198	1	HOUR METER KIT	[2]
	56112138	1	KIT-LASER	
	56112140	1	KIT-WET FLOOR HOLDER	
	56112312	1	KIT-MOP HOLDER	
	56112244	1	KIT-CHEMICAL INJECTION EU	
			SC800-71 Squeegee Blade Kits	
	56112330	1	BLADE KIT-SQUEEGEE GUM	[3]
	56112331	1	BLADE KIT-SQUEEGEE LINATEX	[4]
	56112332	1	BLADE KIT-SQUEEGEE PU	[5]
			SC800-86 Squeegee Blade Kits	
	56115334	1	SQUEEGEE KIT-BLADE-GUM	[3]
	56115333	1	SQUEEGEE KIT-BLADE-LINATEX	[4]
	56115335	1	SQUEEGEE KIT-BLADE-PU	[5]
			Accessories	
	56112222	1	UTILITY CADDY	
	56112255	1	PROGRAMMER WITH CABLE	
	56384137	1	IDLER W/O-RING KIT	
	56112221	1	KIT PARKING BRAKE	[2]
	56112355	1	KIT-REFILLING HOSE	
	56044596	1	LITERATURE PACK	[6]
			SC800-71 Disk Scrub Brushes	
	56505800	2	PAD HOLDER-14 3 LUG	
	56505195	2	PAD RETAINER	
	56505805	2	DISC BRUSH-14 PROLITE 3 LUG	
	56505804	2	DISC BRUSH-14 PROLENE 3 LUG	
	56505806	2	DISC BRUSH-14 UNION MIX 3 LUG	
	56505803	2	DISC BRUSH-14 AGLITE 3 LUG	
	56505807	2	DISC BRUSH-14 MIDGRIT 3 LUG	
	56505808	2	DISC BRUSH-14 MIDLITE 3 LUG	
	56505802	2	DISC BRUSH-14 DYNAGRIT 3 LUG	
	56505801	2	DISC BRUSH-14 MAGNAGRIT 3 LUG	
			SC800-86 Disk Scrub Brushes	
	56505780	2	PAD HOLDER-17 3 LUG	
	56505195	2	PAD RETAINER	
	56505785	2	DISC BRUSH-17 PROLITE 3 LUG	
	56505784	2	DISC BRUSH-17 PROLENE 3 LUG	
	56505786	2	DISC BRUSH-17 UNION MIX 3 LUG	
	56505783	2	DISC BRUSH-17 AGLITE 500 Ø430 mm	
	56505787	2	DISC BRUSH-17 MIDGRIT 3 LUG	
	56505788	2	DISC BRUSH-17 MIDLITE 3 LUG	
	56505782	2	DISC BRUSH-17 DYNAGRIT 3 LUG	
	56505781	2	DISC BRUSH-17 MAGNAGRIT 3 LUG	
			SC800-71 Cylindrical Scrub Brushes	
	56412191	2	BRUSH SOFT NYLON 28-YELLOW	[2]
	56412192	2	BRUSH HARD NYLON 28-NATURAL	
	56412046	2	BRUSH POLYPROPYLENE 28-RED	
	56412193	2	BRUSH 180 GRIT 28-BLUE/GREY	
	56412194	2	BRUSH 80 GRIT 28 BLACK	[2]
	56412195	2	BRUSH 46 GRIT 28 ORANG/BROWN	[2]

Part Notes:

- [1] - NOT FOR SALE VIA EDC
- [2] - COMPLEXITY REDUCTION
- [3] - All squeegee blade kits include both front and rear squeegee blades
- [4] - All squeegee blade kits include both front and rear squeegee blades.

- [5] - All squeegee blade kits include both front and rear squeegee blades. Optional, Not Included
- [6] - NOT FOR EU

RECOMMENDED SPARE PARTS

SC800 71C NIL

2017.11.02

2016.11.02

Pos.	Product no	QTY	Description	Notes
	40628A	4	BRUSH CARBON MOTOR	[1]
	56397098	1	CARBON BRUSH SET	[2]
	56112242	2	CARBON BRUSH KIT	[3]
	56412257	1	BRUSH CAP ASSY	[4]
	56407391	2	BLADE DECK GUM	
			SC800-71 Squeegee Blade Kits	
	56112330	1	BLADE KIT-SQUEEGEE GUM	[5]
	56112331	1	BLADE KIT-SQUEEGEE LINATEX	[5]
	56112332	1	BLADE KIT-SQUEEGEE PU	[5]
			SC800-86 Squeegee Blade Kits	
	56115334	1	SQUEEGEE KIT-BLADE-GUM	[5]
	56115333	1	SQUEEGEE KIT-BLADE-LINATEX	[5]
	56115335	1	SQUEEGEE KIT-BLADE-PU	[5]
			ORDINARY MAINTENANCE	
	56112308	1	CASTER-SWIVEL 4.00 X 2.00	
			EXTRAORDINARY MAINTENANCE	
	56112109	2	WHEEL-SCRUBBER-10.5 X 3.5	
	56112147	1	SOLENOID VALVE ASSY	[6]
	56112543	1	TRANSAXLE	
	56380158	2	FLANGE KIT	[7]
	56382670	1	KIT TRANSAXLE MOTOR	[7]
	40280A	1	ACTUATOR BOOST 32	[8]
	9100000860	1	FILTER WATER SIP	[9]
	9100000861	1	NET WATER FILTER REINFORCED SIP	[10]
	9097456000	1	BRACKET ACTUATOR GALV.	
	54689A	1	GAS SPRING 500N	
	56396197	1	POTENTIOMETER 100K	[11]
	56397029	1	POTENTIOMETER 5K	[12]
	56109716	1	PADDLE-BACK COVER	
	56315230	1	PADDLE FRONT COVER	
	56315280	1	KNOB	
	56112351	1	KIT-AXP CONTROL BOARD	
	56303553	1	KEY SWITCH ASSEMBLY	[13]
	56303526	1	KEY REPLACEMENT SET OF 2	[14]
	56112253	1	KIT-INTERFACE PANEL	[15]
	56112187	1	SPEED CONTROLLER 70A 24V	[16]
	56315256	1	CIRCUIT BREAKER 30 AMP	[17]
	56397088	1	CONTACTOR 24V SPDT	[18]
	56412089	1	FUSE 150 AMP	[19]
	56507644	1	CIRCUIT BREAKER 10 AMP	[20]
	41075A	2	RELAY	[21]
	56384102	1	MOTOR-VAC-24V-DEPHI CONNECTOR	[22]
	56112316	1	HOSE-REC-1.5 X 45	
	909 6634 000	1	CABLE SS STOP-LID	
	56344168	1	FILTER	
	56112310	1	DRAIN HOSE-RECOVERY	
	56112303	1	KIT-FLOAT BALL CAGE	
	56109651	1	BRUSH PLATE ASSY-CCW	[23]
	56109652	1	BRUSH PLATE ASSY-CW	[24]
	56112523	1	LINKAGE BRACKET WELDMENT	
	56112240	2	MOTOR GEARBOX ASSY	[25]
	56112259	1	BRUSH SKIRT ASSY-28D LEFT	[26]
	56112261	1	BRUSH SKIRT ASSY-34D LEFT	[27]
	56112260	1	BRUSH SKIRT ASSY-28D RIGHT	[26]
	56112262	1	BRUSH SKIRT ASSY-34D RIGHT	[27]
	56112306	1	KIT-BRISTLE SKIRT 28	[28]
	56112307	1	KIT-BRISTLE SKIRT 34	[29]
	56601450	1	WHEEL 4.00 OD	
	30412A	1	HOSE SOLUTION VISION	

RECOMMENDED SPARE PARTS

SC800 71C NIL

2017.11.02

2016.11.02

Pos.	Product no	QTY	Description	Notes
	56112521	1	GIMBAL-COLLAR ASSEMBLY	
	56366455	1	PLATE CV24B	
	56109653	1	SPRING RETAINER	
	56601056	1	SPRING BRUSH HOLDER	
	56601118	1	BRUSH PLATE	
	56112111	2	MOTOR-24 VDC 3/4HP	[25]
	56112523	1	LINKAGE BRACKET WELDMENT	
	56315321	2	BELT AUTO TENSION	
	56115318	2	DRIVE END ASSY	
	56115314	2	GUARD ASSY-BELT	
	56115344	2	IDLER END ASSY	
	56407303	2	KNOB	[30]
	56412459	2	WHEEL	
	30412A	1	HOSE SOLUTION VISION	
	909 6380 000	1	CLAMP KIT	
	56112145	1	TUBE-PRESSURE SENSING	
	56383997	1	HOSE-PVC-5/8X19	
	56419275	3	GASKET	
	56112554	1	KIT-SOLUTION LEVEL	
	9100000803	1	VALVE ELBOW SIP	
	9100000703	1	HOSE FILLING SIP	
	56112345	1	FILL HOSE SUPPORT	
	56510442	1	CAP-EXTRA VENT	
	56112108	2	WHEEL	
	909 6883 000	2	WHEELS SQUEEGEE 60X20MM KIT 2PCS	
	56370711	2	NUT THUMB	
	9100000515	1	SUPPORT SQUEEGEE SPRING PLAST. SIP	
	52557A	1	KNOB SQUEEGEE LIFT ENCORE17	
	909 6635 000	2	HOLDER.FLAT TIE	

Part Notes:

- [1] - for 50981A
- [2] - for 56384102
- [3] - for 56112240
- [4] - for 56112111
- [5] - All squeegee blade kits include both front and rear squeegee blades
- [6] - L1
- [7] - for 56112543
- [8] - M2
- [9] - TSB-FC-2013-127
- [10] - for 9100000362
- [11] - R2
- [12] - R1
- [13] - for 56112351 S3
- [14] - for 56303553
- [15] - Membrane Switch, Membrane Panel, Gasket
- [16] - A2
- [17] - CB1
- [18] - K2
- [19] - F1
- [20] - CB2
- [21] - K1 / K3
- [22] - M5
- [23] - CCW
- [24] - CW
- [25] - M3 / M4
- [26] - SC800-71
- [27] - SC800-86
- [28] - SC800-71/ Includes two skirts and mounting hardware

RECOMMENDED SPARE PARTS

SC800 71C NIL

2017.11.02

2016.11.02

- [29] - SC800-86/ Includes two skirts and mounting hardware
- [30] - for 56115344

We provide brushes and pad holders that will give you the best possible performance between machine and floor. Following are descriptions of the materials and their applications.

- ProLite: Bristles are made from light-duty polypropylene for general scrubbing when you do not want to scratch or remove finish from the floor. Recommended for use in place of red pads.
- Prolene: Polypropylene material for medium-duty scrubbing on concrete, terrazzo and vinyl floor tile. Recommended for use in place of green or blue pads.
- Union Mix: Medium grade natural fibers for polishing finished floors with standard-speed equipment. Recommended for use in place of white pads.
- AgLite Grit 500: For light scrubbing when used wet; buffing or polishing when used dry on urethane coated, sealed concrete or other resilient hard surface floors. Recommended for use in place of red or white pads.
- MidGrit 240: For general purpose scrubbing when you need a lighter action for sealed or unsealed concrete, stone, terrazzo, quarry tile and other resilient hard floor surfaces. Recommended for use in place of green or blue pads.
- MidLite Grit 180: For general purpose scrubbing of sealed or unsealed concrete, stone, terrazzo, quarry tile and other resilient hard floor surfaces. Recommended for use in place of green or blue pads.
- Dyna Grit 80: For aggressive, heavy-duty scrubbing or stripping of floors. Recommended for use in place of brown pads.
- Magna Grit 46: For extreme heavy-duty scrubbing or stripping of floors. This brush has extra large diameter silicon carbide grit impregnated synthetic bristles. Recommended for use in place of black pads.
- Short Trim
- Pad Holder: Made with a structural foam block and center ring for correct pad centering. It has a "shower feed" design for getting solution to the floor.

BA 756 BRUSHES

- 56505800 - Short Trim Pad Holder
- 56505195 - Pad Retainer for 56505800
- 56505805 - ProLite
- 56505804 - Prolene
- 56505806 - Union Mix
- 56505803 - AgLite Grit 500
- 56505807 - MidGrit 240
- 56505808 - MidLite Grit 180
- 56505802 - Dyna Grit 80
- 56505801 - Magna Grit 46

BA 856 BRUSHES

- 56505780 - Short Trim Pad Holder
- 56505195 - Pad Retainer for 56505800
- 56505785 - ProLite
- 56505784 - Prolene
- 56505786 - Union Mix
- 56505783 - AgLite Grit 500
- 56505787 - MidGrit 240
- 56505788 - MidLite Grit 180
- 56505782 - Dyna Grit 80
- 56505781 - Magna Grit 46

DISC BRUSH APPLICATION GUIDE (SUGGESTION ONLY)

	46	80	180	240	500			Union
Application	Grit	Grit	Grit	Grit	Grit	Prolene	Prolite	Mix
Stripping:								
Concrete	X	X						
Terrazzo	X	X						
Ceramic/Quarry tile		X						
Vinyl tile		X						
General Scrubbing:								
Concrete	X	X	X	X		X		
Terrazzo			X	X	X	X		
Ceramic/Quarry tile			X	X	X	X		
Marble					X		X	
Vinyl tile			X		X	X		
Raised-rubber tile					X		X	
Polishing:								
Raised Disc Tile								X
Marble								X
Vinyl tile								X

Resource notes:

Pos. 1-10: BA 756 BRUSHES Pos. 20-29 BA 856 BRUSHES

Pos.	Product no	QTY	Description	Notes
1	56505800	1	PAD HOLDER-14 3 LUG	
2	56505195	1	PAD RETAINER	[1]
3	56505805	1	DISC BRUSH-14 PROLITE 3 LUG	
4	56505804	1	DISC BRUSH-14 PROLENE 3 LUG	
5	56505806	1	DISC BRUSH-14 UNION MIX 3 LUG	
6	56505803	1	DISC BRUSH-14 AGLITE 3 LUG	
7	56505807	1	DISC BRUSH-14 MIDGRIT 3 LUG	
8	56505808	1	DISC BRUSH-14 MIDLITE 3 LUG	
9	56505802	1	DISC BRUSH-14 DYNAGRIT 3 LUG	
10	56505801	1	DISC BRUSH-14 MAGNAGRIT 3 LUG	
20	56505780	1	PAD HOLDER-17 3 LUG	
21	56505195	1	PAD RETAINER	[1]
22	56505785	1	DISC BRUSH-17 PROLITE 3 LUG	
23	56505784	1	DISC BRUSH-17 PROLENE 3 LUG	
24	56505786	1	DISC BRUSH-17 UNION MIX 3 LUG	
25	56505783	1	DISC BRUSH-17 AGLITE 500 Ø430 mm	
26	56505787	1	DISC BRUSH-17 MIDGRIT 3 LUG	
27	56505788	1	DISC BRUSH-17 MIDLITE 3 LUG	
28	56505782	1	DISC BRUSH-17 DYNAGRIT 3 LUG	
29	56505781	1	DISC BRUSH-17 MAGNAGRIT 3 LUG	

Part Notes:

[1] - FOR 56505800

We provide brushes and pad holders that will give you the best possible performance between machine and floor. Following are descriptions of the materials and their applications.

- Soft Nylon: Least aggressive brush available. Used on soft-finish floors where a more aggressive brush would leave scratch marks, or in applications requiring very light cleaning.
- Stiff Nylon: Cleaning action similar to polypropylene. More durable and wear-resistant than polypropylene.
- Prolene: Low cost, yet effective in cleaning many common floor surfaces.
- MidLite Grit 180: Least aggressive grit brush. Used for daily cleaning of hard-finished floors.
- Dyna Grit 80: Medium aggressive grit brush. Good all-around brush for medium to heavy buildup removal. Can also be used for general stripping operations.
- Magna Grit 46: Most aggressive grit brush. Used primarily to clean heavy buildup on concrete floors in factories, or for heavy stripping of finish.

BA 756 BRUSHES

- 56412191 - Soft Nylon
- 56412192 - Hard Nylon
- 56412046 - Prolene
- 56412193 - MidLite Grit 180
- 56412194 - Dyna Grit 80
- 56412195 - Magna Grit 46

CYLINDRICAL BRUSH APPLICATION GUIDE (SUGGESTION ONLY)

Application	46 Grit	80 Grit	180 Grit	Polypropylene	Stiff Nylon	Soft Nylon
Stripping:						
Concrete	X	X				
Terrazzo	X	X				
Ceramic/Quarry tile		X				
Vinyl tile		X				
General Scrubbing:						
Concrete	X	X	X	X	X	
Terrazzo			X	X	X	X
Ceramic/Quarry tile			X	X	X	X
Marble			X		X	X
Vinyl tile			X	X	X	X
Raised-rubber tile			X			X

Pos.	Product no	QTY	Description	Notes
1	56412191	1	BRUSH SOFT NYLON 28-YELLOW	[1]
2	56412192	1	BRUSH HARD NYLON 28-NATURAL	
3	56412046	1	BRUSH POLYPROPYLENE 28-RED	
4	56412193	1	BRUSH 180 GRIT 28-BLUE/GREY	
5	56412194	1	BRUSH 80 GRIT 28 BLACK	[1]
6	56412195	1	BRUSH 46 GRIT 28 ORANG/BROWN	[1]

Part Notes:

[1] - COMPLEXITY REDUCTION

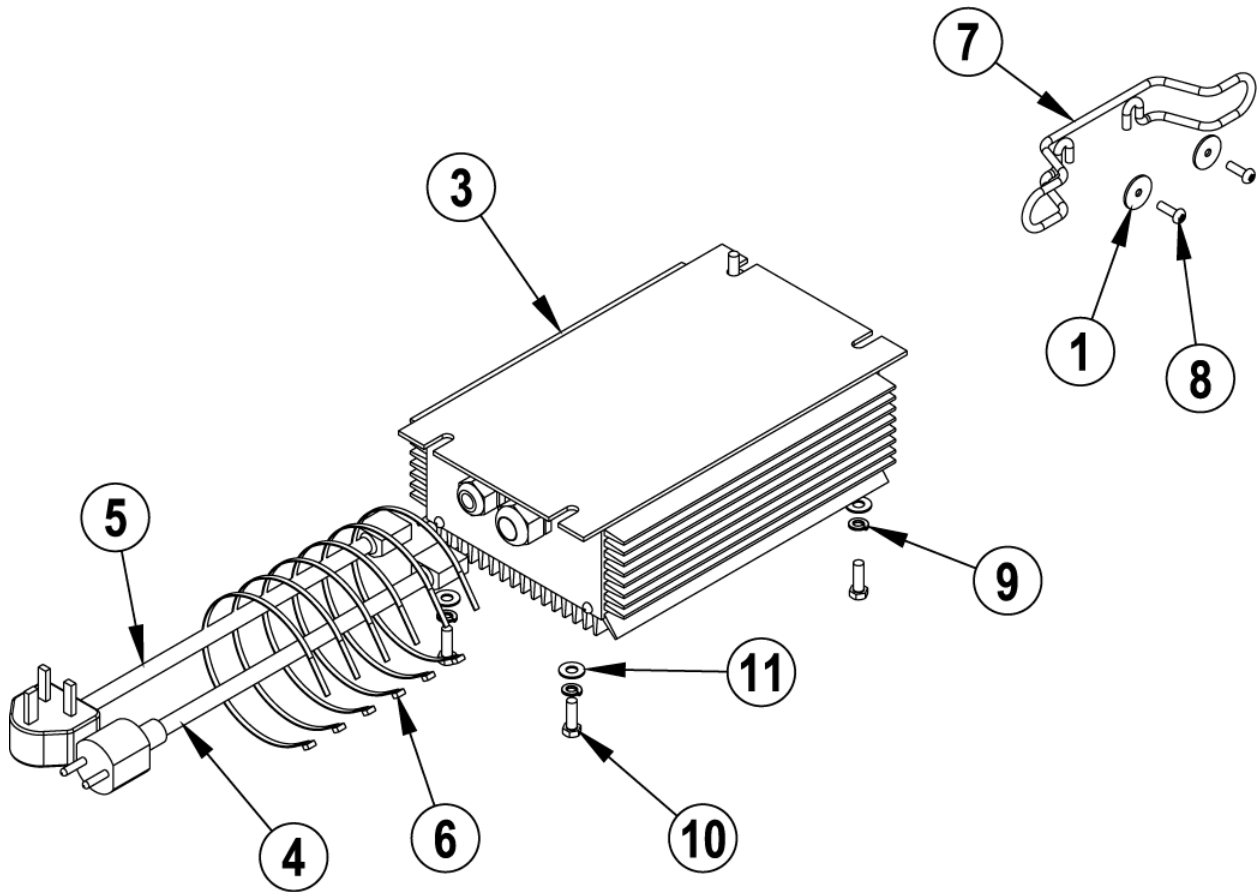

Pos.	Product no	QTY	Description	Notes
00	56112245	1	KIT-ON BOARD CHARGER-EU	[1]
1	56009096	2	WSH FLT .193X.875X.060	
3	56114378	1	BATTERY CHARGER 24V 25A	[1]
4	56383388	1	CORD-CHARGER EUROPE	
5	56383389	1	CORD-CHARGER UK	
6	56478523	8	CABLE TIE E00549	
7	1466317000	1	SUPPORT BATTERY CHARGER CABLE KIT	
8	964004	2	SCREW M5X16 PN ST PH	
9	980657	4	WASHER LOCK 1/4 STD	
10	57994A	4	SCREW M6 X 20 HEX HD	
11	87026A	4	WASHER .250 FLAT SS	[2]

Part Notes:

- [1] - TSB US 2011 Charger Interlock Wiring Update
- [2] - EXPIRED USE 56002859

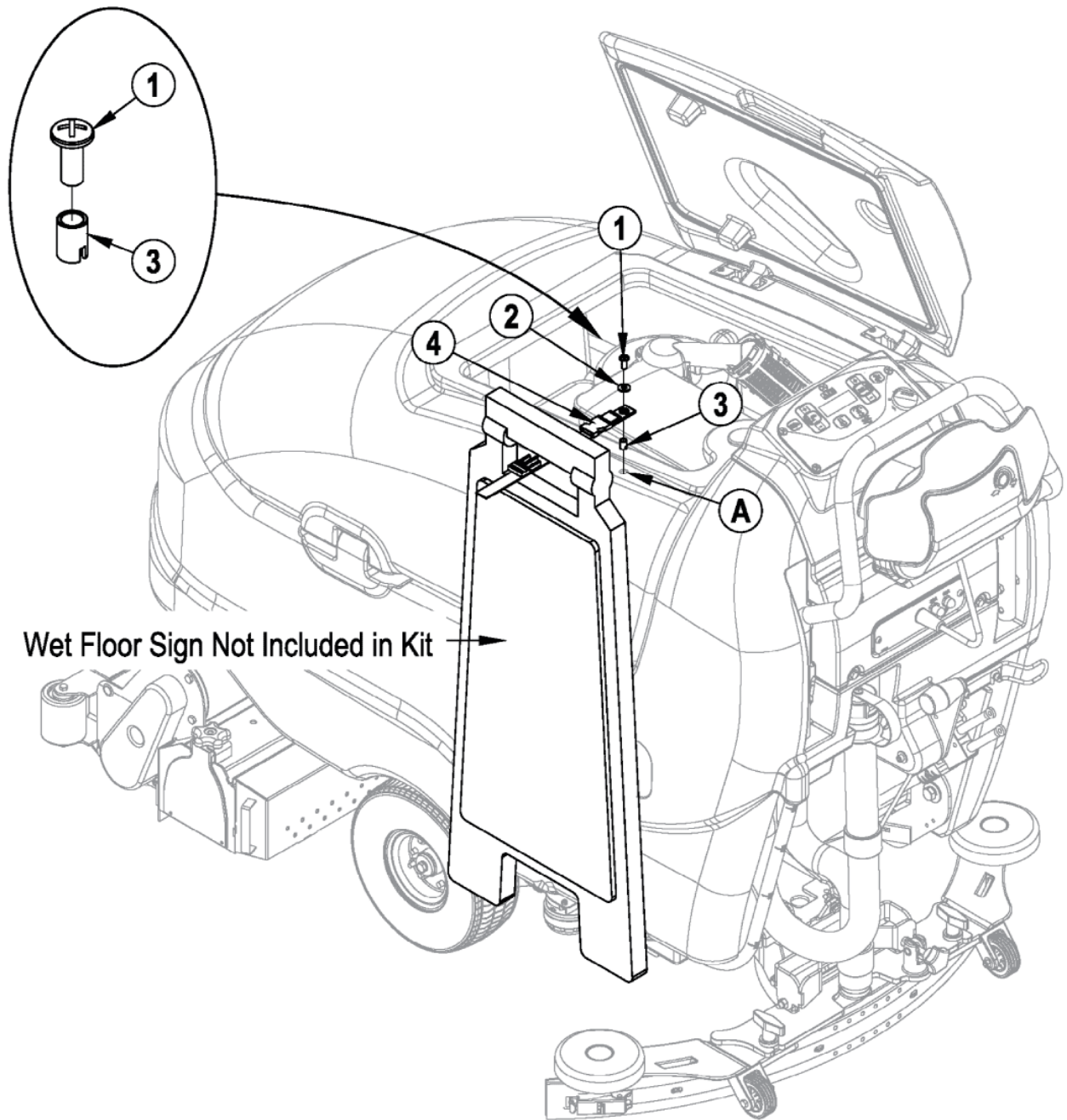

56112140 - Wet Floor Sign Holder Kit

SC800 71C NIL

2017.11.02

2013.04.02

Pos.	Product no	QTY	Description	Notes
00	56112140	1	KIT-WET FLOOR HOLDER	
01	56002066	1	SCR PAN PHIL 1/4-20 X .62	
02	56002098	1	H FLT SAE 1/4	
03	56009034	1	SCR PAN PHIL THD FORM 8-32X.88	
04	56112149	1	POLYPROPYLENE STRAP	

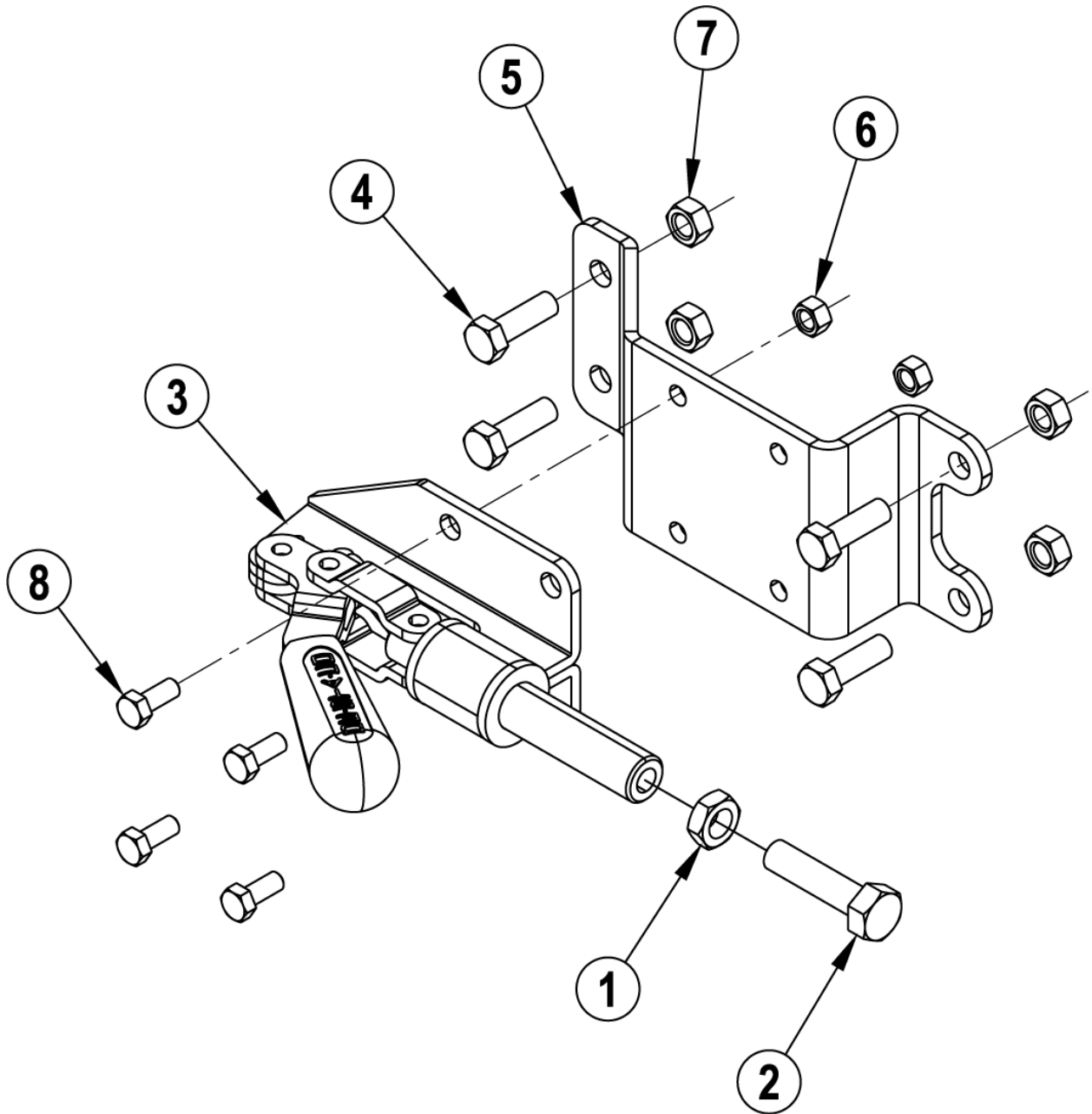

Pos.	Product no	QTY	Description	Notes
00	56112221	1	KIT PARKING BRAKE	[1]
01	920160	1	NUT-5/16-18 HEX JAM	
02	962157	1	SCR 5/16-18 X 1-1/4 HX ST CAP	
03	54772A	1	CLAMP TOGGLE STRAIGHT LINE	
04	57994A	4	SCREW M6 X 20 HEX HD	
05	61934A	1	BRACKET BRAKE	
06	56003975	4	NUT HEX NYL LOC SS M5-0.8	
07	80199A	4	NUT M6-1 HEX NYLON LOCK S.S.	
08	80249A	4	SCREWM5-.8X12MM HEX HEAD S.S.	

Part Notes:

[1] - COMPLEXITY REDUCTION

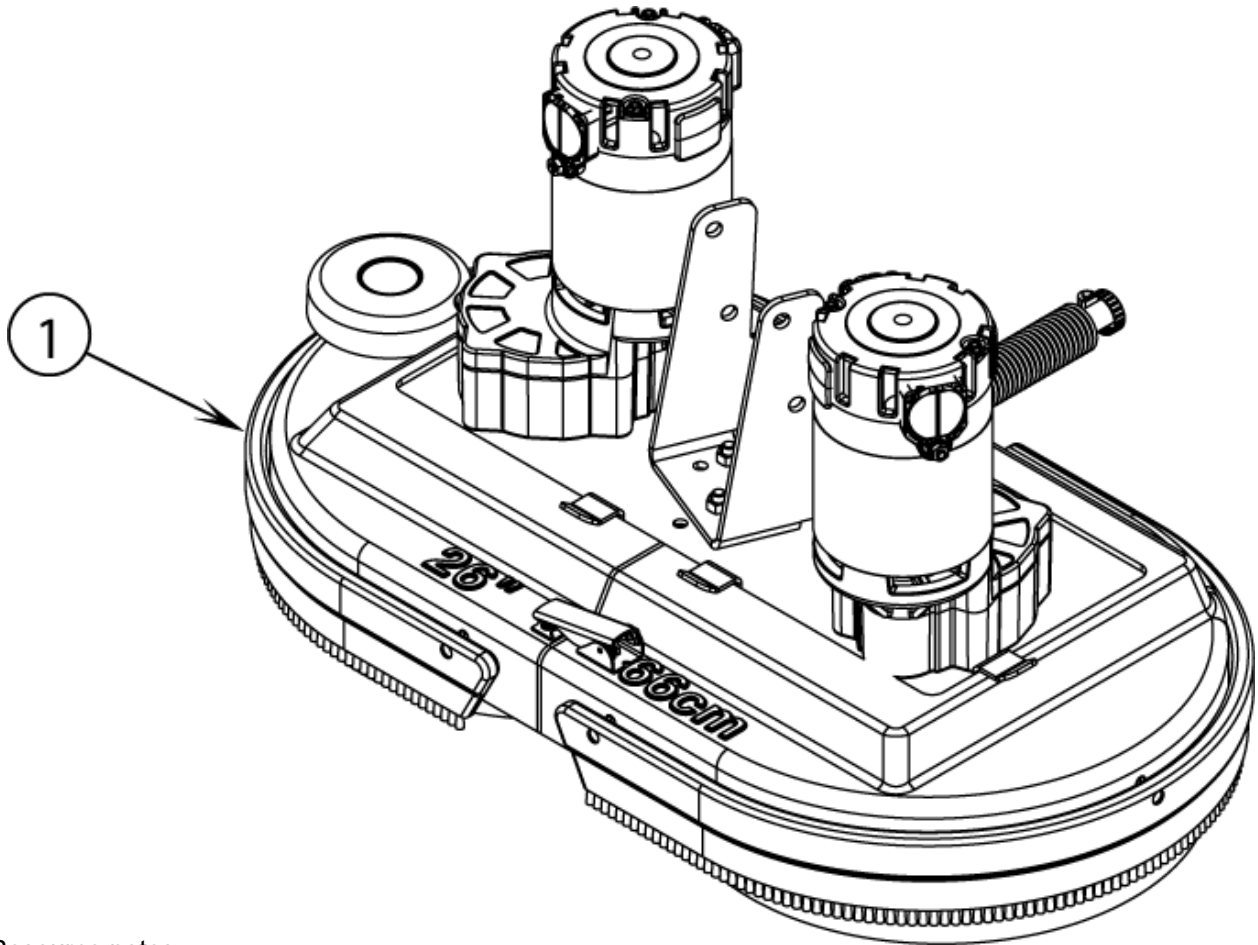

Resource notes:

Pos. 1-19: Compatible 26" Brushes Pos. 30: Available 26" Disc Deck Skirt Pos. 40: Compatible Squeegee Pos. 50-55: Squeegee Blade Kits for 56112265

Pos.	Product no	QTY	Description	Notes
01		1	SCRUB SYSTEM 26" DISC	[1]
10	56505760	1	PAD HOLDER-13 3 LUG	
11	56505195	1	PAD RETAINER	
12	56505765	1	DISC BRUSH-13 PROLITE 3 LUG	
13	56505764	1	DISC BRUSH-13 PROLENE 3 LUG	
14	56505766	1	DISC BRUSH-13 UNION MIX 3 LUG	
15	56505763	1	DISC BRUSH-13 AGLITE 3 LUG	
16	56505767	1	DISC BRUSH-13 MIDGRIT 3 LUG	
17	56505768	1	DISC BRUSH-13 MIDLITE 3 LUG	
18	56505762	1	DISC BRUSH-13 DYNAGRIT 3 LUG	
19	56505761	1	DISC BRUSH-13 MAGNAGRIT 3 LUG	
50	56112247	1	BLADE KIT-SQUEEGEE GUM	[2]
52	56112332	1	BLADE KIT-SQUEEGEE PU	
53	56112330	1	BLADE KIT-SQUEEGEE GUM	
54	56112331	1	BLADE KIT-SQUEEGEE LINATEX	
55	56112332	1	BLADE KIT-SQUEEGEE PU	

Part Notes:

- [1] - SCRUB SYSTEM 26" DISC
 [2] - EXPIRED USE 56112330

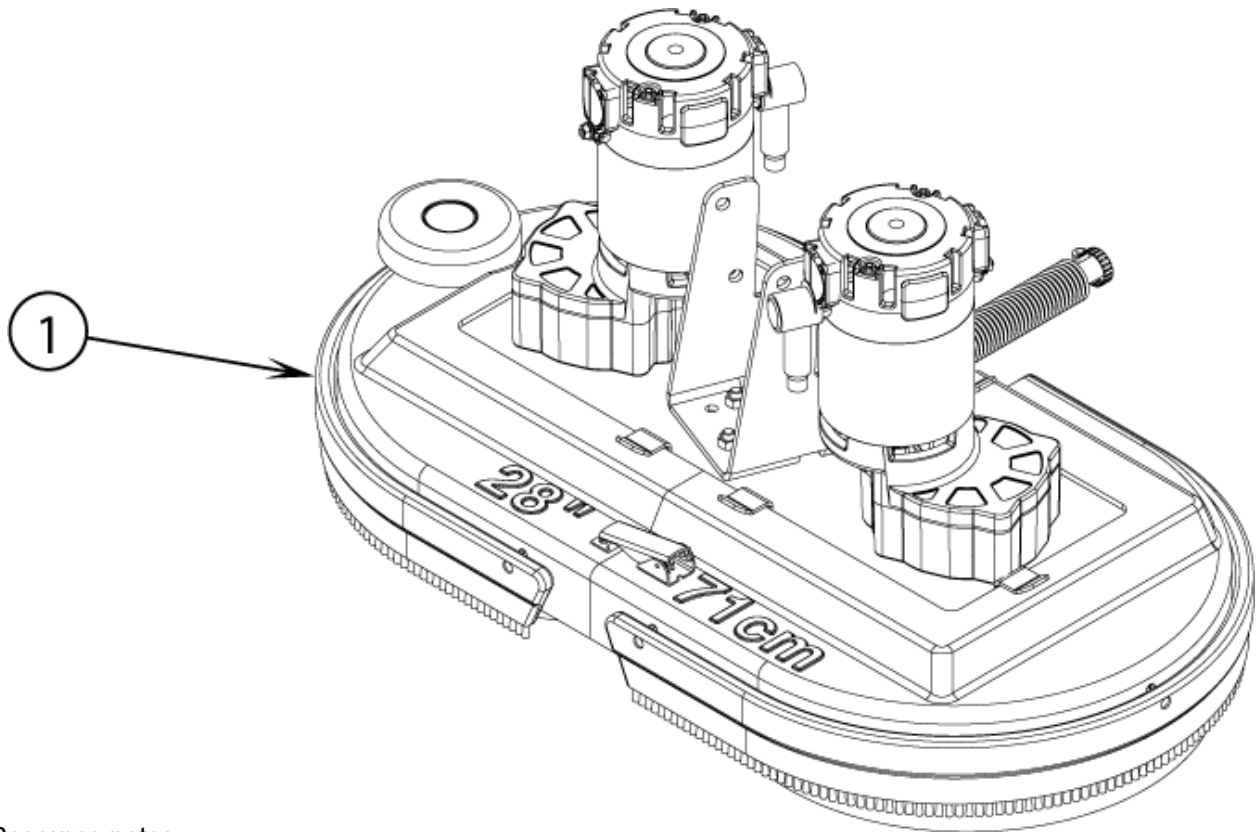

Resource notes:

Pos. 1-19: Compatible 28" Brushes Pos. 30: Available 28" Disc Deck Skirt Pos. 40: Compatible Squeegee Pos. 50-55: Squeegee Blade Kits for 56112266

Pos.	Product no	QTY	Description	Notes
	56112266	1	KIT DISC DECK ASSY 28	[1]
01		1	SCRUBSYSTEM28"DISC	[2]
10	56505800	1	PAD HOLDER-14 3 LUG	
11	56505195	1	PAD RETAINER	
12	56505805	1	DISC BRUSH-14 PROLITE 3 LUG	
13	56505804	1	DISC BRUSH-14 PROLENE 3 LUG	
14	56505806	1	DISC BRUSH-14 UNION MIX 3 LUG	
15	56505803	1	DISC BRUSH-14 AGLITE 3 LUG	
16	56505807	1	DISC BRUSH-14 MIDGRIT 3 LUG	
17	56505808	1	DISC BRUSH-14 MIDLITE 3 LUG	
18	56505802	1	DISC BRUSH-14 DYNAGRIT 3 LUG	
19	56505801	1	DISC BRUSH-14 MAGNAGRIT 3 LUG	
30	56112225	1	BRISTLE SKIRT-28D	
50	56112247	1	BLADE KIT-SQUEEGEE GUM	[3]
52	56112332	1	BLADE KIT-SQUEEGEE PU	
53	56112330	1	BLADE KIT-SQUEEGEE GUM	
54	56112331	1	BLADE KIT-SQUEEGEE LINATEX	
55	56112332	1	BLADE KIT-SQUEEGEE PU	

Part Notes:

- [1] - EXPIRED ON 02/08/2013
- [2] - SCRUBSYSTEM28"DISC
- [3] - EXPIRED USE 56112330

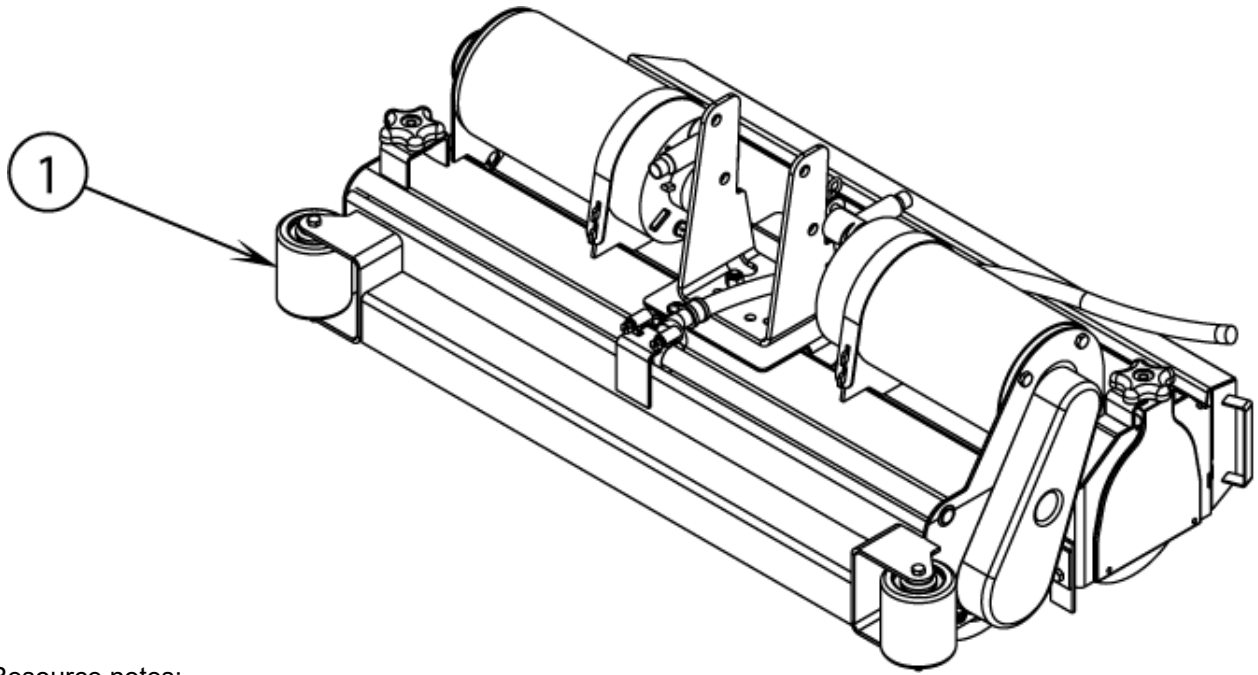

Resource notes:

Pos. 10-15: Compatible 28" Brushes Pos. 30: Available Belt Pos. 40: Available Blade Pos. 50: Compatible Squeegee Pos. 60-65: Squeegee Blade Kits for 56112267

Pos.	Product no	QTY	Description	Notes
	56112267	1	KIT CYLINDRICAL DECK	[1]
01		1	SCRUB SYSTEM 28" CYLINDRICAL	[2]
10	56412191	1	BRUSH SOFT NYLON 28-YELLOW	[3]
11	56412192	1	BRUSH HARD NYLON 28-NATURAL	
12	56412046	1	BRUSH POLYPROPYLENE 28-RED	
13	56412193	1	BRUSH 180 GRIT 28-BLUE/GREY	
14	56412194	1	BRUSH 80 GRIT 28 BLACK	[3]
15	56412195	1	BRUSH 46 GRIT 28 ORANG/BROWN	[3]
30	56315321	1	BELT AUTO TENSION	
40	56407391	1	BLADE DECK GUM	
60	56112247	1	BLADE KIT-SQUEEGEE GUM	[4]
62	56112332	1	BLADE KIT-SQUEEGEE PU	
63	56112330	1	BLADE KIT-SQUEEGEE GUM	
64	56112331	1	BLADE KIT-SQUEEGEE LINATEX	
65	56112332	1	BLADE KIT-SQUEEGEE PU	

Part Notes:

- [1] - EXPIRED ON 02/11/2013
- [2] - SCRUB SYSTEM 28" CYLINDRICAL
- [3] - COMPLEXITY REDUCTION
- [4] - EXPIRED USE 56112330

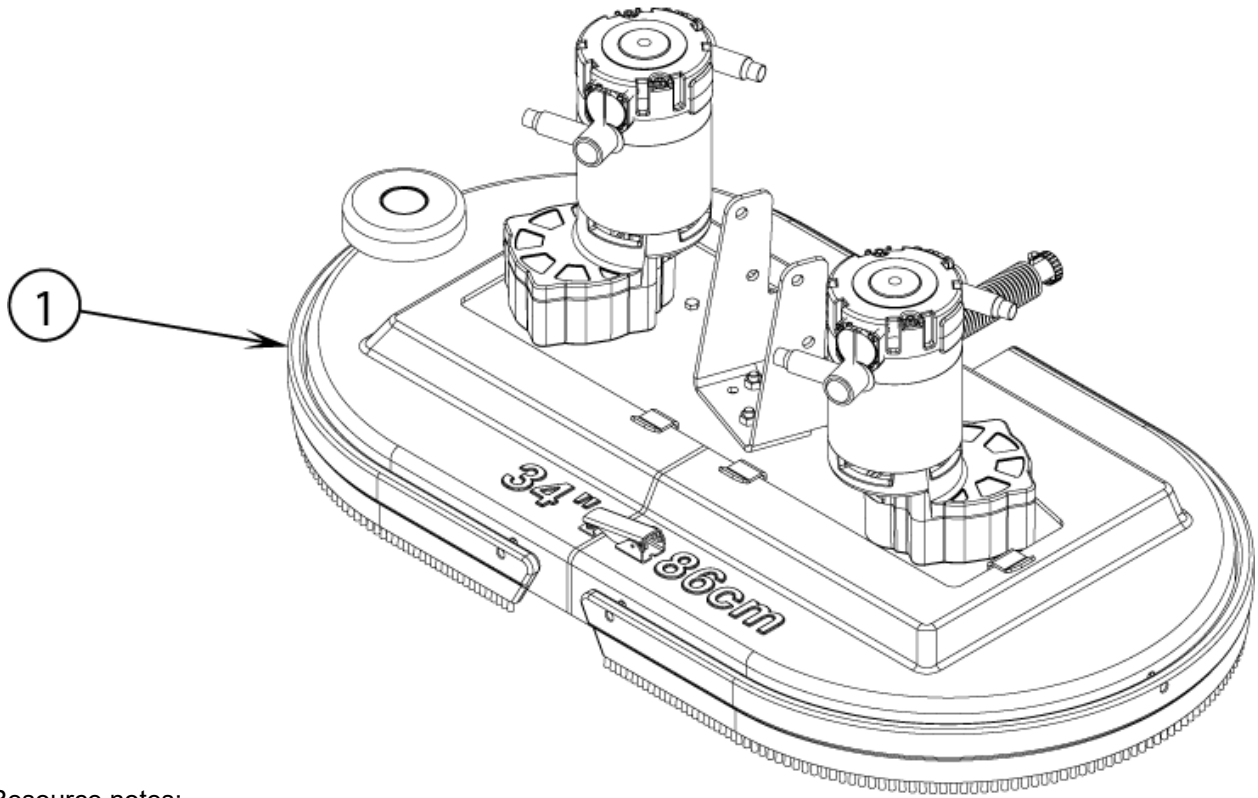

Resource notes:

Pos. 10-19: Compatible 34" Brushes Pos. 30: Available 34" Disc Deck Skirt Pos. 40: Compatible Squeegee Pos. 50-55: Squeegee Blade Kits for 56112279

Pos.	Product no	QTY	Description	Notes
	56112279	1	KIT DISC DECK ASSY	[1]
01		1	SCRUB SYSTEM 34" DISC	[2]
10	56505780	1	PAD HOLDER-17 3 LUG	
11	56505195	1	PAD RETAINER	
12	56505785	1	DISC BRUSH-17 PROLITE 3 LUG	
13	56505784	1	DISC BRUSH-17 PROLENE 3 LUG	
14	56505786	1	DISC BRUSH-17 UNION MIX 3 LUG	
15	56505783	1	DISC BRUSH-17 AGLITE 500 Ø430 mm	
16	56505787	1	DISC BRUSH-17 MIDGRIT 3 LUG	
17	56505788	1	DISC BRUSH-17 MIDLITE 3 LUG	
18	56505782	1	DISC BRUSH-17 DYNAGRIT 3 LUG	
19	56505781	1	DISC BRUSH-17 MAGNAGRIT 3 LUG	
30	56112227	1	BRISTLE SKIRT-34D	
50	56115334	1	SQUEEGEE KIT-BLADE-GUM	
51	56115333	1	SQUEEGEE KIT-BLADE-LINATEX	
52	56112252	1	BLADE KIT-SQUEEGEE PU	[3]
53	56115334	1	SQUEEGEE KIT-BLADE-GUM	
54	56115333	1	SQUEEGEE KIT-BLADE-LINATEX	
55	56115335	1	SQUEEGEE KIT-BLADE-PU	

Part Notes:

- [1] - COMPLEXITY REDUCTION
- [2] - SCRUB SYSTEM 34" DISC
- [3] - EXPIRED USE 56112335

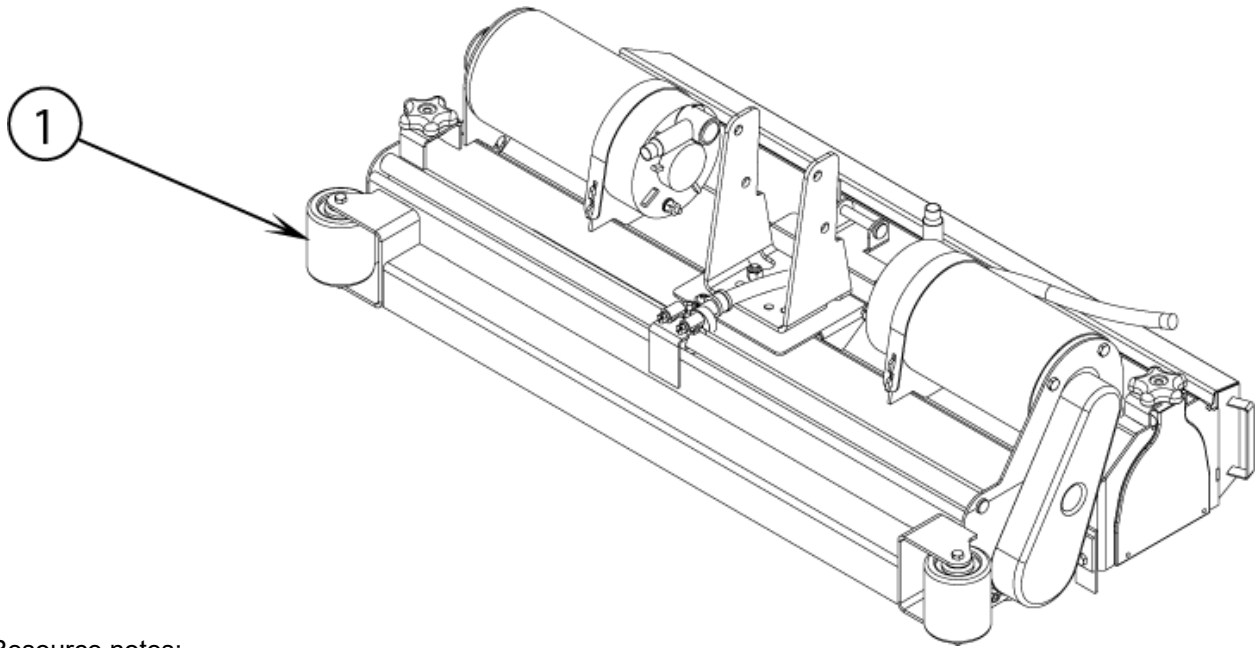

Resource notes:

Pos. 10-15: Compatible 32" Brushes Pos. 30: Available Belt Pos. 40: Available Blade Pos. 50: Compatible Squeegee Pos. 60-65: Squeegee Blade Kits for 56112280

Pos.	Product no	QTY	Description	Notes
01		1	SCRUBSYSTEM32"CYLINDRICAL	[1]
10	56407473	1	BRUSH SOFT NYLON 32-YELLOW	
11	56407474	1	BRUSH HARD NYLON 32-NATURAL	
13	56407476	1	BRUSH 180 GRIT 32-BLUE/GREY	
14	56407477	1	BRUSH 80 GRIT 32-BLACK	
15	56407478	1	BRUSH 46 GRIT 32-ORANGE/BROWN	
30	56315321	1	BELT AUTO TENSION	
40	56407391	1	BLADE DECK GUM	
60	56115334	1	SQUEEGEE KIT-BLADE-GUM	
61	56115333	1	SQUEEGEE KIT-BLADE-LINATEX	
62	56112252	1	BLADE KIT-SQUEEGEE PU	[2]
63	56115334	1	SQUEEGEE KIT-BLADE-GUM	
64	56115333	1	SQUEEGEE KIT-BLADE-LINATEX	
65	56115335	1	SQUEEGEE KIT-BLADE-PU	

Part Notes:

- [1] - SCRUBSYSTEM32"CYLINDRICAL
 [2] - EXPIRED USE 56112335

Pos.	Product no	QTY	Description	Notes
00	56112138	1	KIT-LASER	
01	56001954	4	WSH FLT SAE 10	
02	56002453	2	SCR PAN PHIL 10-24 X .25	
03	56003377	1	SCR PAN PHIL M5X12MM	
04	56003627	2	SCR PAN PHIL M6-1.00 X 16MM	
05	56003811	1	SCR-SOC SET SS NYL TIP 6-32X	
07	56112136	1	LASER	
08	56112137	1	LASER HOUSING	
09	56112142	1	CLEAR LENS	
10	56112143	1	LASER SUPPORT BRKT	
11	56112146	1	LASER SHIELD	
12	56112264	2	T-KNOB ASSEMBLY	
13	56112298	1	DECAL-LASER WARNING	
14	56112301	1	DECAL-LASER WARNING	
15	56478523	2	CABLE TIE E00549	
16	52548A	1	TAB 1/4 SCREW ENCORE 17	

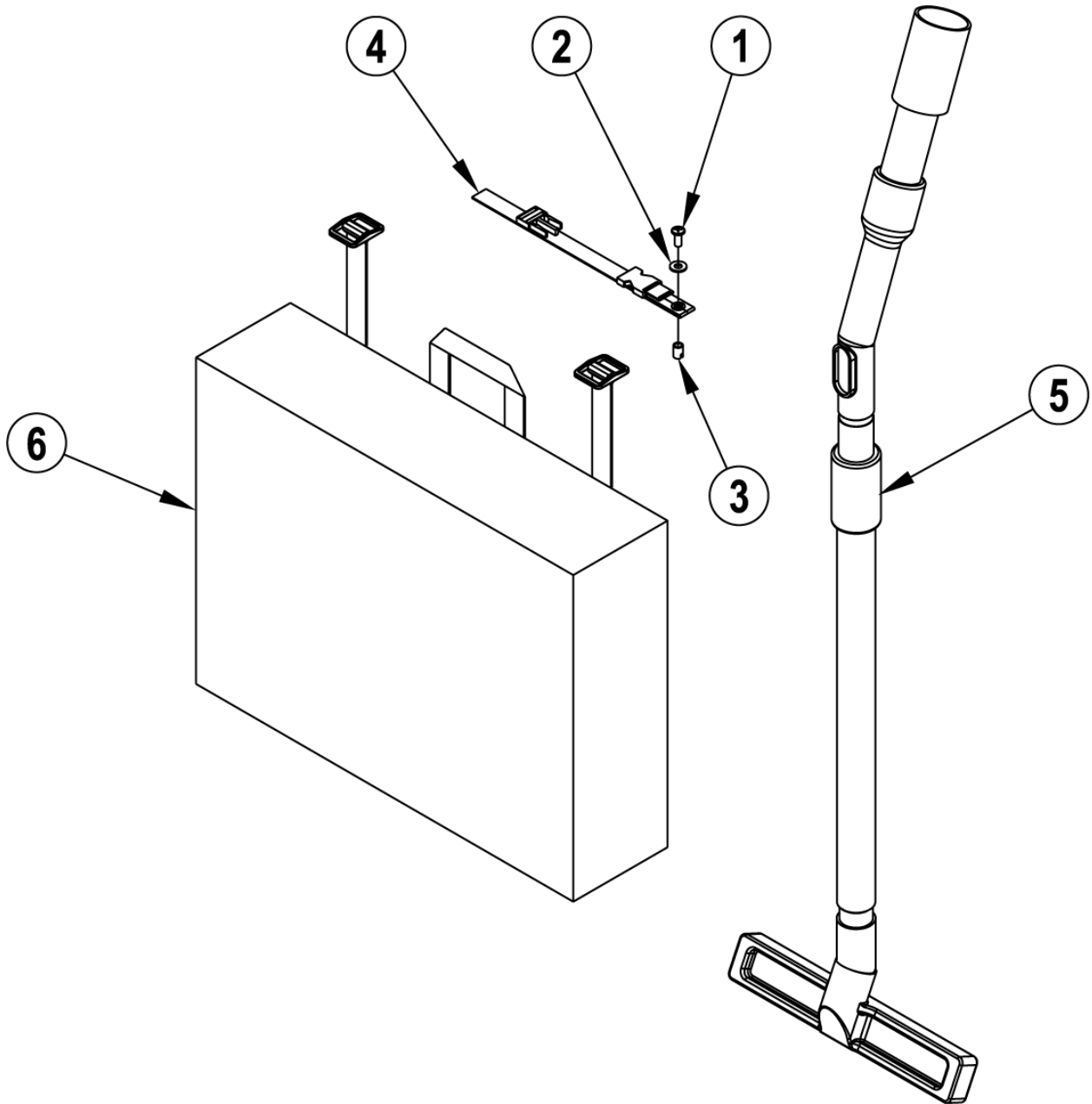

56112141 - Vacuum Wand with Tote Bag Kit

SC800 71C NIL

2017.11.02

2013.04.02

Pos.	Product no	QTY	Description	Notes
00	56112141	1	KIT-VAC WAND WITH TOTE BAG	
01	56002066	1	SCR PAN PHIL 1/4-20 X .62	
02	56002098	1	H FLT SAE 1/4	
03	56009304	1	INSERT SELF TAPPING 1/4-20	
04	56112149	1	POLYPROPYLENE STRAP	
05	56315309	1	SCRUB/VAC WAND & HOSE	
06	56315316	1	TOTE BAG	

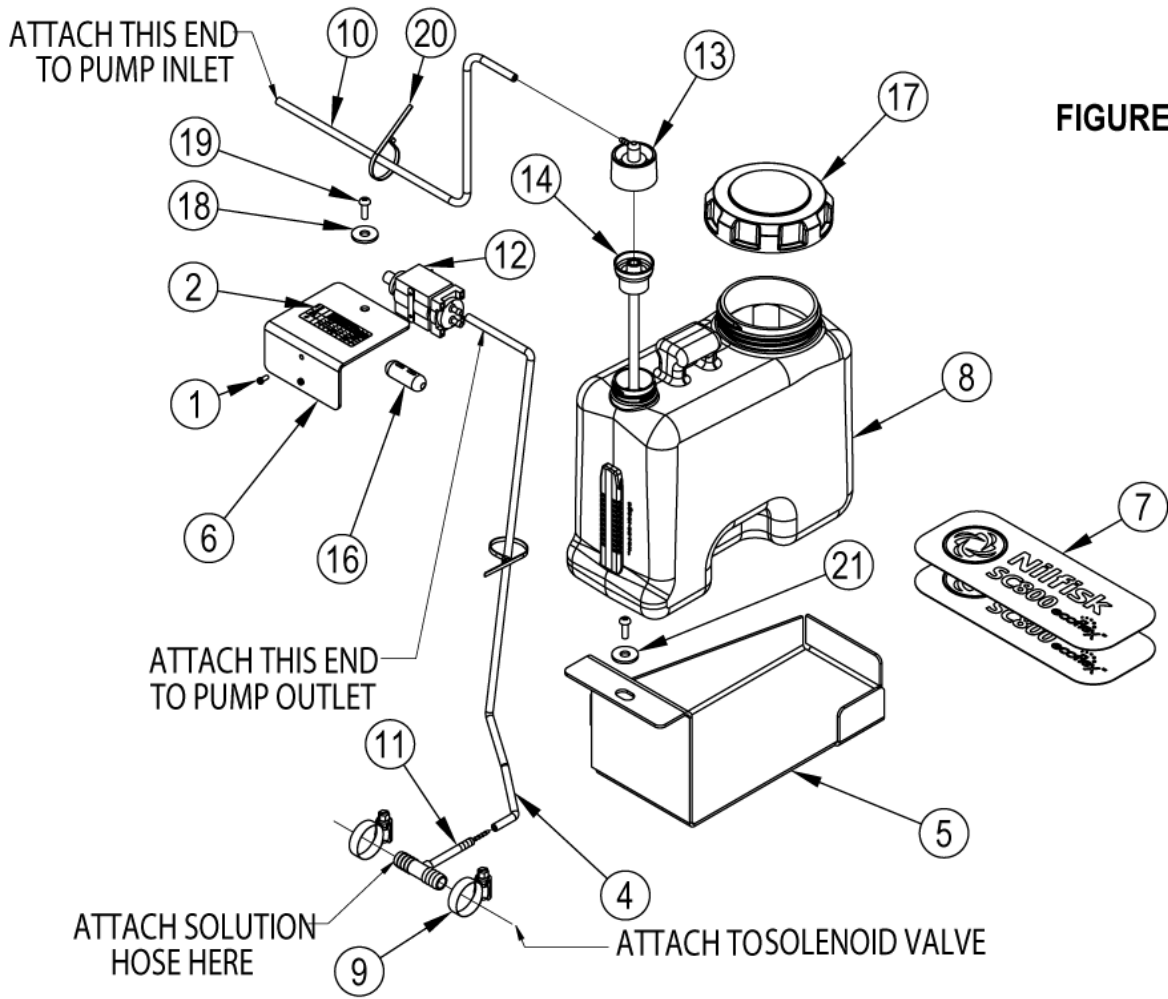

Pos.	Product no	QTY	Description	Notes
00	56112244	1	KIT-CHEMICAL INJECTION EU	
01	56002539	2	SCR PAN PHIL TD FORM 6-32 X.31	
02	56016331	1	DECAL CHEMICAL RATIO	
04	56413692	1	HOSE CHEMICAL RESISTANT 21.00	
05	56112125	1	BRACKET-BOTTLE SUPPORT	
06	56112126	1	BRACKET-PUMP MOUNT	
07	56112532	2	DECAL-NILFISK SC800 ECOFLEX	
08	56601544	2	CHEMICAL BOTTLE ASSEMBLY	
09	56219932	1	CLAMP HOSE SAE 6 E00047	
10	56306169	1	HOSE CHEM RESISTANT 17.00	
11	56314983	1	TEE ASSEMBLY	
12	56315241	1	PUMP CHEMICAL	
13	56315523	1	CAP DRY BREAK 1/8 BARB	
14	56315527	1	INSERT DRY BREAK	
16	56601514	1	FERRITE BEAD	
17	9100001817	1	CAP PLASTIC F DETERGENT SOLU. TANK SIP	
18	56002098	1	H FLT SAE 1/4	
19	56003627	1	SCR PAN PHIL M6-1.00 X 16MM	
20	56325219	2	CABLE TIE E00549 HC360C	
21	56009060	1	WSH FLT SS .260X1.000X.074	

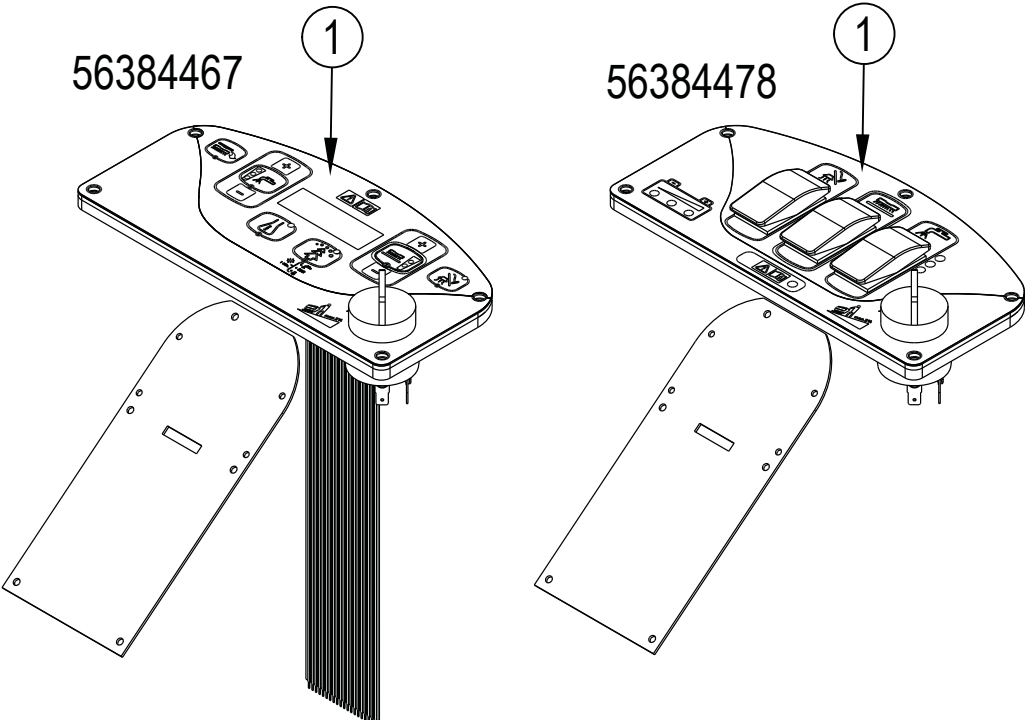

56112351/56112352 - Control Panel Kits

SC800 71C NIL

2018.04.03

2020.02.12

Pos.	Product no	QTY	Description	Notes
	56112351	1	KIT-AXP CONTROL BOARD	[1]
1	56112352	1	KIT-ST CONTROL BOARD	[2]
1	56384467	1	INTERFACE PANEL ASSY-AXP	[3]

Part Notes:

- [1] - 56384467
- [2] - 56384478
- [3] - 56112351
NON-SALEABLE USE 56112351

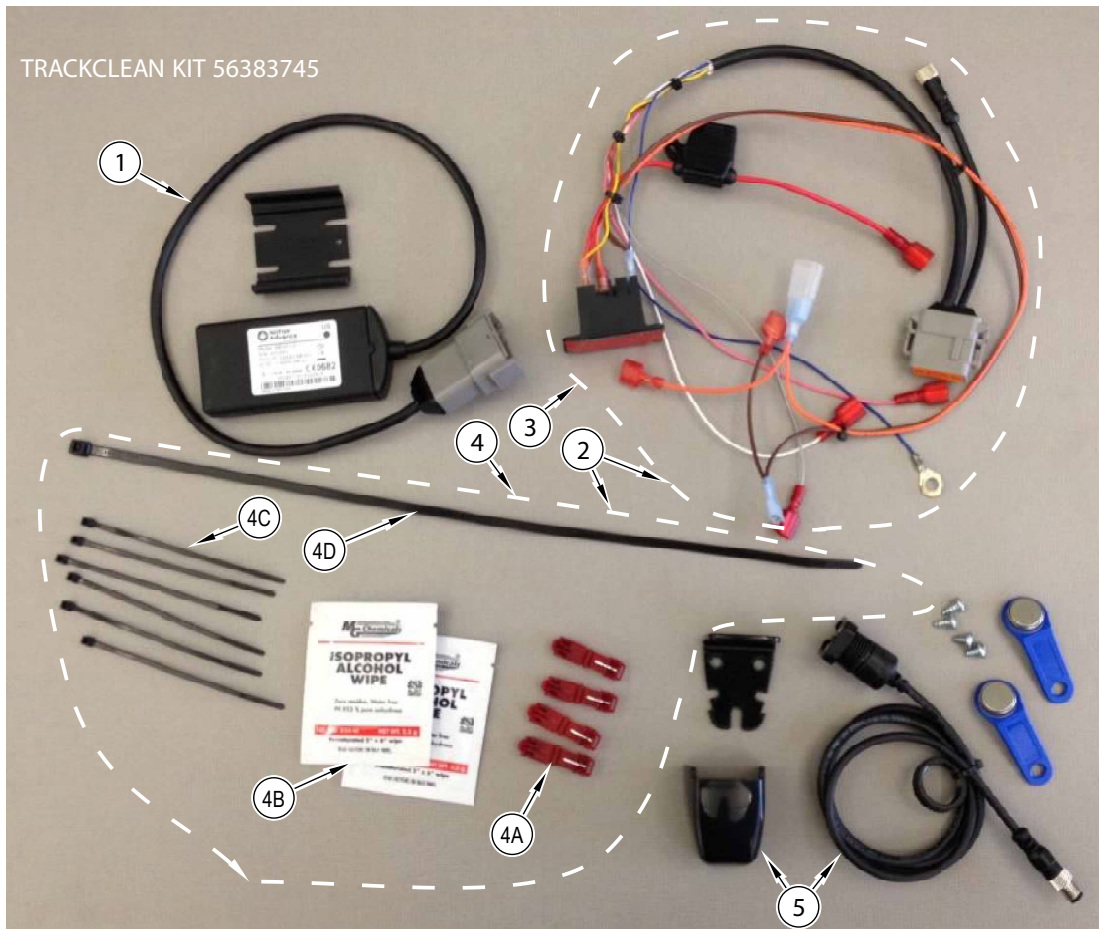

Pos.	Product no	QTY	Description	Notes
0	56383745	1	TRKCLN SC800 KIT-RDR	
1		1	ME401-9 EU SIM card module (module, bracket)	
2		1	TrackClean System with reader	
3		1	Harness with reader	
4		1	Hardware Kit	
4A		4	Red tap 18-22 AWG (Wire Splice Connector)	
4B		2	Alcohol wipe	
4C		6	Cable tie, 4" x 0.10", black	
4D		1	Cable tie, 8" x 0.18", black	
5		1	TrackClean reader kit (reader, 2 user keys)	

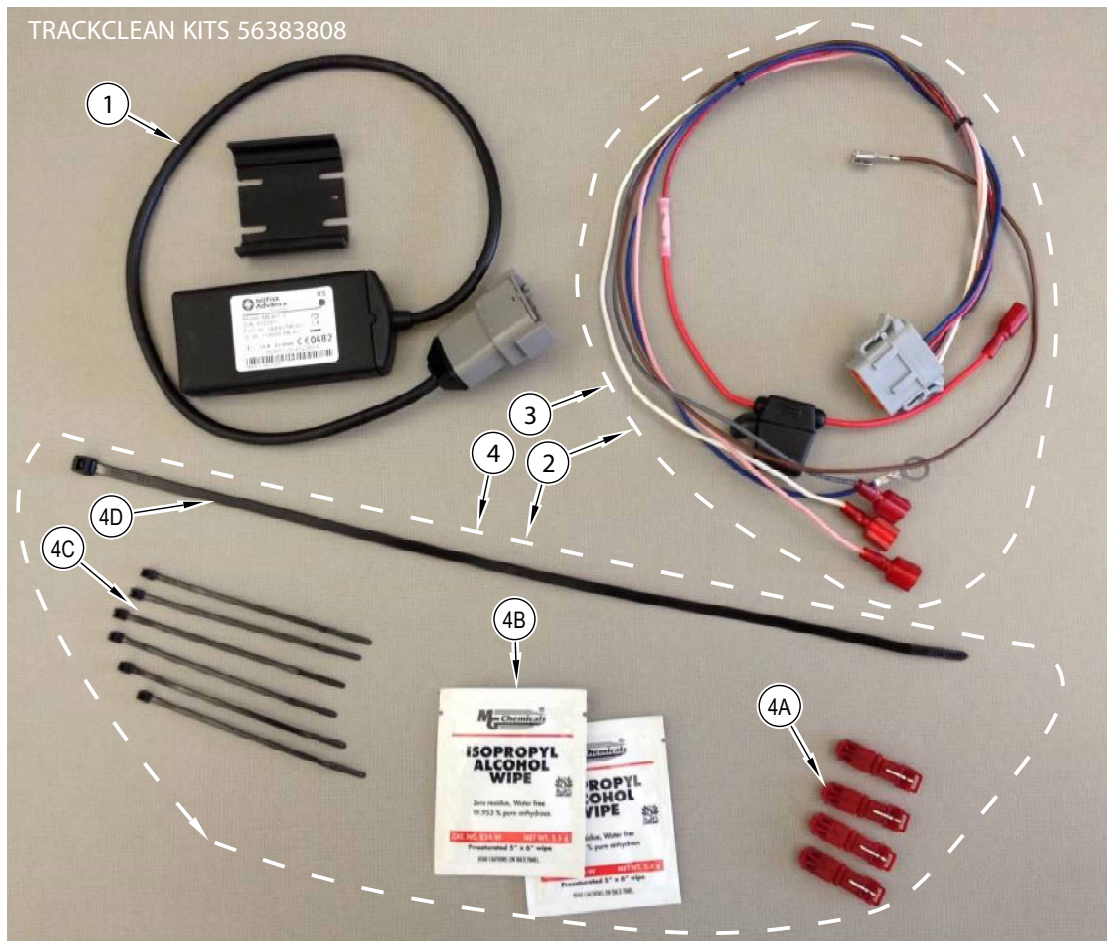

Pos.	Product no	QTY	Description	Notes
0	56383808	1	TRKCLN SC800 KIT	
1		1	ME401-9 EU SIM card module (module, bracket)	
2		1	TrackClean System without reader	
3		1	Harness without reader	
4		1	Hardware Kit	
4A		4	Red tap 18-22 AWG (Wire Splice Connector)	
4B		2	Alcohol wipe	
4C		6	Cable tie, 4" x 0.10", black	
4D		1	Cable tie, 8" x 0.18", black	
